

FRENIC-Mini Series

FRENIC



Mini

FUJI INVERTERS

GREAT PERFORMANCE IN A COMPACT PACKAGE
WELCOME TO THE NEW GENERATION
OF MICRO INVERTERS

FRENIC-Mini Series Concepts



Actual size

Ideal functions to meet various needs

New, compact design

Simple operation

Flexible through optionals

A broad range of model variations

Global products

Fuji Electric is the world's top market share manufacturer* of general-purpose inverters in the 5HP class or below.

Based on our experience and customer's needs, we have now integrated our advanced designs and industry-leading technologies to develop a new inverter series, called FRENIC-Mini.

The FRENIC-Mini features a full range of functions, compact body, simple operation, wide model variations, and global compatibility. It will meet your needs for higher performance in machines and equipment such as conveyors, fans, pumps, centrifugal separators and food processing machines, as well as the needs for system integration, energy saving, labor saving, and total cost reduction.

*Quoted from "Low Power AC Drive Worldwide Outlook" (2001) published by ARC(USA)



Optimum performance for traversing conveyors

High starting torque, at 150% or more

Equipped with Fuji's original simplified torque-vector control system and the automatic torque boost function, the inverter provides consistent powerful operation (when automatic torque boost is ON, slip compensation control is ON, and when running at 5Hz or more).

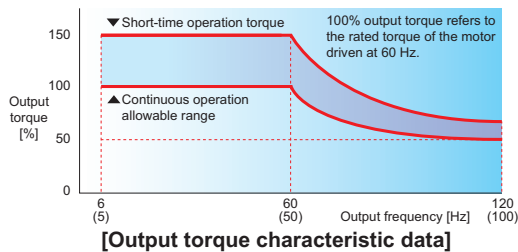
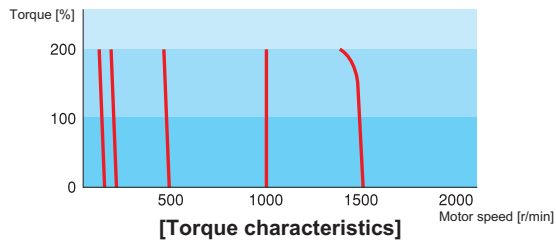

*The above graph shows an example of torque characteristics obtained when FRENIC-Mini is combined one-to-one with Fuji's standard three-phase motor (8-type series; 4 poles).

Braking resistor connectable to the inverter

Owing to a built-in braking transistor (1/2HP or larger), an optional braking resistor can be connected to increase the regenerative braking capacity for conveyance and transportation machinery that require large braking power. For inverters of 2HP or larger, it is possible to select the model that incorporates a braking resistor.

Trip-free operation

The remarkably improved current limiting function (stall prevention) allows trip-free operation even for an impact load.

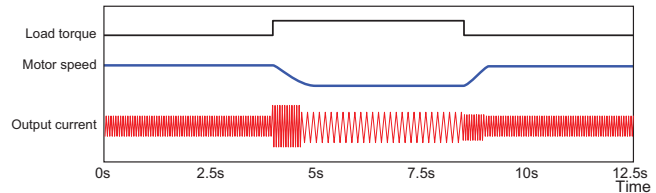

Stable operation even for a step load

The slip compensation function permits stable operation even when the motor load fluctuates (step load).

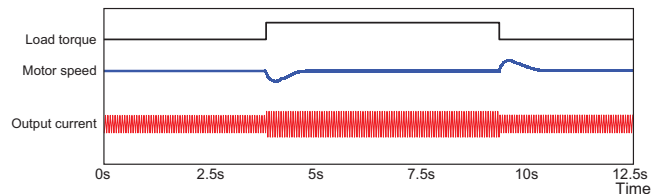

Reduced motor instability at low speed

Fuji's unique control method improves voltage control performance and reduces motor instability at low speed to about a half or less (at 1Hz) compared with that of conventional inverters.

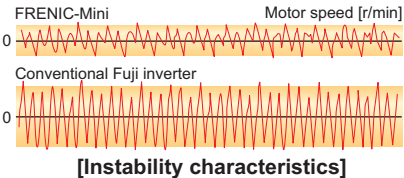

The highly used functions for fans and pumps

Automatic energy-saving provided as a standard function

By controlling the motor loss to a minimum, FRENIC-Mini further saves electric power when applied to fans or pumps.

*Energy saving rate varies with the motor characteristics.

PID control function

Permits motor operation while controlling temperature, pressure, or flow rate without using an external device such as temperature controller.

Cooling fan ON/OFF control function

The inverter's cooling fan can be turned off while the fan or pump is stopped for noise reduction and energy savings.

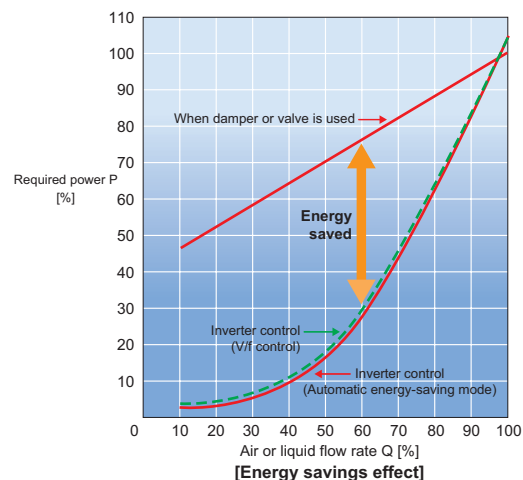

*Energy savings rate varies with the motor characteristics.



Safety Precautions

1. The contents of this catalog are provided to help you select the product model that is best for you. Before actual use, be sure to read the Instruction Manual/User's Manual thoroughly to assure correct operation.
2. This product is not designed and manufactured for use in machines or systems which human life is dependent upon. If you are studying use of the products in this brochure for special purposes such as for control of nuclear power stations, in sea, air or space craft, in medical or land transportation equipment, or any related systems, please contact the business office of Fuji Electric. If these products are to be used in any equipment in which there is a risk to human life or the possibility of a major loss in the event of failure, be sure to install the appropriate safety equipment.

BEST MATCH

The ideal functions to serve a multiplicity of needs for small-capacity inverters

Compatible with a wide range of frequency settings

The optimum frequency setting method can be selected to match your machine or equipment. Setting can be done by keypad panel (●● keys, potentiometer), analog input (4 to 20mA, 0 to +10V, 0 to 5V, 1 to 5V), multistep speed settings (8 steps) etc.

A transistor output is provided.

This enables an overload early warning, lifetime forecast or other information signals to be output during operation.

The output frequency can be set to a maximum of 400Hz.

The inverter can be used for equipment that requires a high motor speed such as centrifugal separator. In this case, check the operation in combination with the motor.

Two points can be set for a non-linear V/f pattern.

One point for the non-linear V/f pattern, which can be set as desired, has been added (making a total of 2 points), and so the V/f pattern can be adjusted to match the application.



Compact

Side-by-side mounting is possible.

Multiple inverter units can be mounted side-by-side inside a panel. This feature helps to minimize the space used for installation. (Ambient temperature: 40°C (104°F) or less)

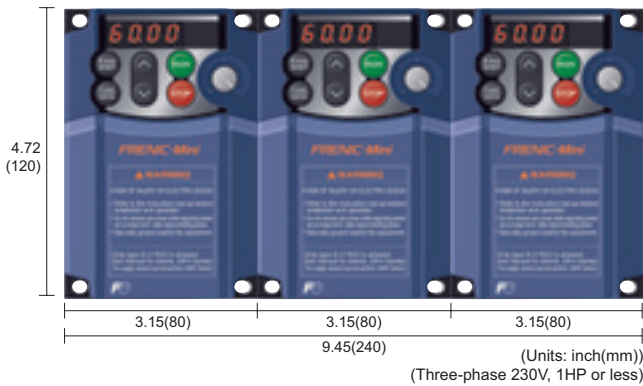

Size interchangeability with Fuji's FVR-C11S series is provided.

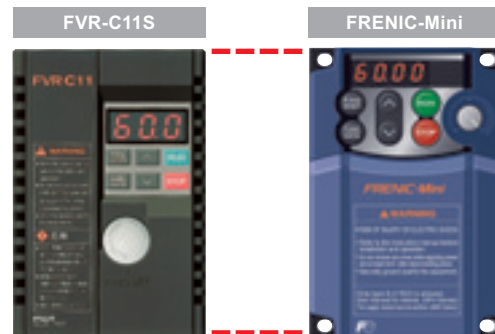

RS485 communications card (option) can be installed internally.

This card can be installed inside the inverter's body without changing the dimensions. RS-485 communications are available as option.



A model with built-in braking resistor is available on order.

For inverters of 2HP or larger, a built-in braking resistor type can be selected.

Since installation and wiring of a separate braking resistor is not required, the total mounting space is reduced.

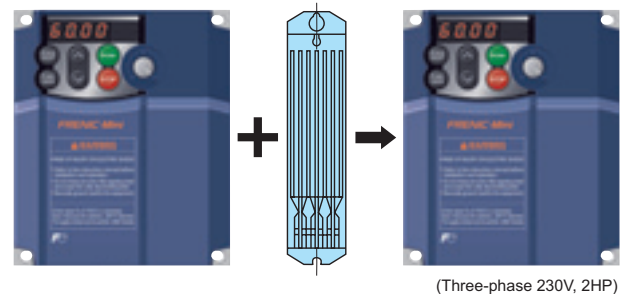



Simple operation and wiring

Frequency setting potentiometer is standard equipment.

The frequency can be adjusted easily by hand.

The control circuit terminal block cover and main circuit terminal block cover can be quickly removed.

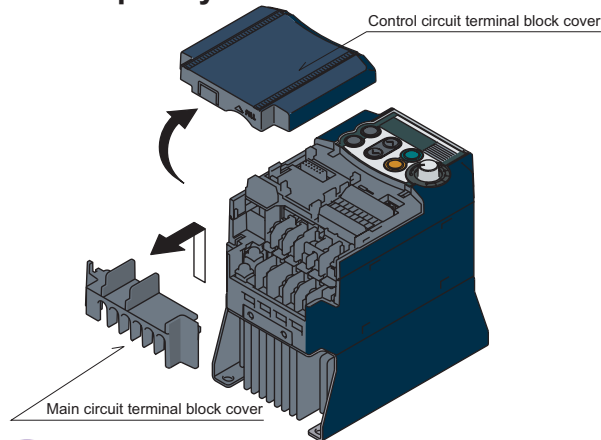

All types of data can be displayed on the keypad.

The output frequency, set frequency, load shaft speed, output current, output voltage, alarm history, input power etc. can be displayed.



A menu mode is included in the keypad.

The menu items include the "function menu" for checking or changing function codes, "operation monitor", "I/O check", "maintenance info." and "alarm info." See the FRENIC-Mini User's Manual for details.



Maintenance

The lifetime of the DC bus capacitor can be estimated.

The capacitor's condition compared with its initial state can be confirmed.

A long-life cooling fan is included.

Use of a long-life cooling fan (design life: 7 years with an ambient temperature: 40°C (104°F)) reduces maintenance work.

Cumulative running time is recorded and displayed.

The inverter records and displays the cumulative running time (lifetime) of the inverter itself, PCB, and cooling fan.

The alarm history for the 4 latest alarms is recorded.

Detailed information from back as far as the 4 latest alarms can also be checked.

It is possible to output lifetime forecast signal to the transistor output.

This signal is output when the capacitors in the DC bus circuit, the electrolytic capacitors on the PCB or the cooling fans are nearing the end of their service life.



Interface for peripheral devices and comprehensive protective functions

All models are equipped with an inrush current suppression circuit.

An inrush current suppression circuit is provided as standard in all models, so the cost of peripheral devices such as input magnetic contactors can be reduced.

A DC reactor (DCR) connection terminal is provided as standard.

A terminal for connection of a DCR, necessary for suppressing harmonics, is provided in all models.

Input/output phase loss protective function

It is possible to detect output phase loss at all times during starting and operation.

Sink/Source can be switched.

The input/output mode (Sink/Source) of the digital input terminals can be switched by means of an internal jumper switch.

The motor can be protected by a PTC thermistor.

In addition to the protection by an electronic thermal relay, the motor is protected by a PTC thermistor input.



Flexible through optionals

Function code copy function

The optional remote keypad panel includes a built-in copy function, so function codes can be set easily in duplicate units.

Inverter support loader software is available.

The inverter support loader program (Windows based), which simplifies setting of function codes, is provided. The optional RS-485 communications card, remote operation extension cable and USB-RS-485 converter are necessary.

Mounting on DIN rail

Using the rail mounting base (option), the inverter can be easily mounted on a DIN rail (35mm wide).

Replacement of older models with new ones is simple.

The latest models can be mounted without drilling additional holes by use of the mounting adapter (option).

Remote operation is possible.

Remote operation can be done easily using the optional RS-485 communications card, remote keypad and remote operation extension cable.

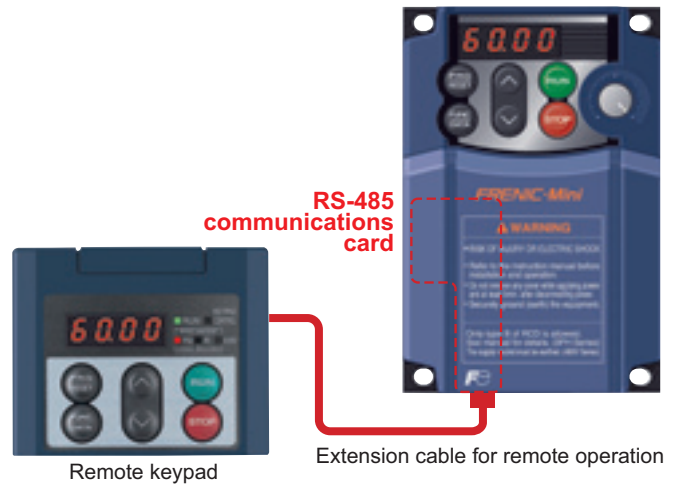

Wide variations

- A 460V series, in addition to the 230V series (Three-phase, single-phase), is available.
- Models with EMC filter built-in, with braking resistor built-in and with RS-485 communications-compliant are also available on order.
 - *The RS-485 communications is applicable on the standard model with using the RS-485 communications card (optional accessory).
- Type1 (NEMA1) conformed model is available by attaching optional parts.



Global products

All standard models comply with the EC Directive (CE marking), UL standards and Canadian standards (cUL certification).

All standard FRENIC-Mini inverters comply with European and North American/Canadian standards, enabling standardization of the specifications for machines and equipment used at home and abroad.

If the model with built-in EMC filter is used, the model conforms to the European EMC Directive.

Europe
EC Directives (CE marking), TÜV



North America/Canada
UL standard (cUL certification)



In addition to the three-phase 230V, single-phase 230V and single-phase 115V, three-phase 460V has been newly introduced, broadening the model selection range.

Model variations include EMC filter built-in type and braking resistor built-in type on order.

| Applicable motor rating | Three-phase 230V | Three-phase 460V | Single-phase 230V | Single-phase 115V |
|--|------------------|------------------|-------------------|-------------------|
| Standard specifications | | | | |
| 1/8 | FRNF12C1S-2U | | FRNF12C1S-7U | FRNF12C1S-6U |
| 1/4 | FRNF25C1S-2U | | FRNF25C1S-7U | FRNF25C1S-6U |
| 1/2 | FRNF50C1S-2U | FRNF50C1S-4U | FRNF50C1S-7U | FRNF50C1S-6U |
| 1 | FRN001C1S-2U | FRN001C1S-4U | FRN001C1S-7U | FRN001C1S-6U |
| 2 | FRN002C1S-2U | FRN002C1S-4U | FRN002C1S-7U | |
| 3 | FRN003C1S-2U | FRN003C1S-4U | FRN003C1S-7U | |
| 5 | FRN005C1S-2U | FRN005C1S-4U | | |
| Semi-standard specifications | | | | |
| EMC filter built-in type (On order) | | | | |
| 1/8 | FRNF12C1E-2U | | FRNF12C1E-7U | |
| 1/4 | FRNF25C1E-2U | | FRNF25C1E-7U | |
| 1/2 | FRNF50C1E-2U | FRNF50C1E-4U | FRNF50C1E-7U | |
| 1 | FRN001C1E-2U | FRN001C1E-4U | FRN001C1E-7U | |
| 2 | FRN002C1E-2U | FRN002C1E-4U | FRN002C1E-7U | |
| 3 | FRN003C1E-2U | FRN003C1E-4U | FRN003C1E-7U | |
| 5 | FRN005C1E-2U | FRN005C1E-4U | | |
| Braking resistor built-in type (On order) | | | | |
| 2 | FRN002C1S-2U21 | FRN002C1S-4U21 | | |
| 3 | FRN003C1S-2U21 | FRN003C1S-4U21 | | |
| 5 | FRN005C1S-2U21 | FRN005C1S-4U21 | | |
| IP40 enclosure type | | | | |
| 1/8 | FRNF12C1J-2U | | | |
| 1/4 | FRNF25C1J-2U | | | |
| 1/2 | FRNF50C1J-2U | FRNF50C1J-4U | | |
| 1 | FRN001C1J-2U | FRN001C1J-4U | | |
| 2 | FRN002C1J-2U | FRN002C1J-4U | | |
| 3 | FRN003C1J-2U | FRN003C1J-4U | | |
| 5 | FRN005C1J-2U | FRN005C1J-4U | | |

Type1 (NEMA1) conformed model is available by attaching optional parts.

How to read the model number

The Compact Inverter *FRENIC-Mini*

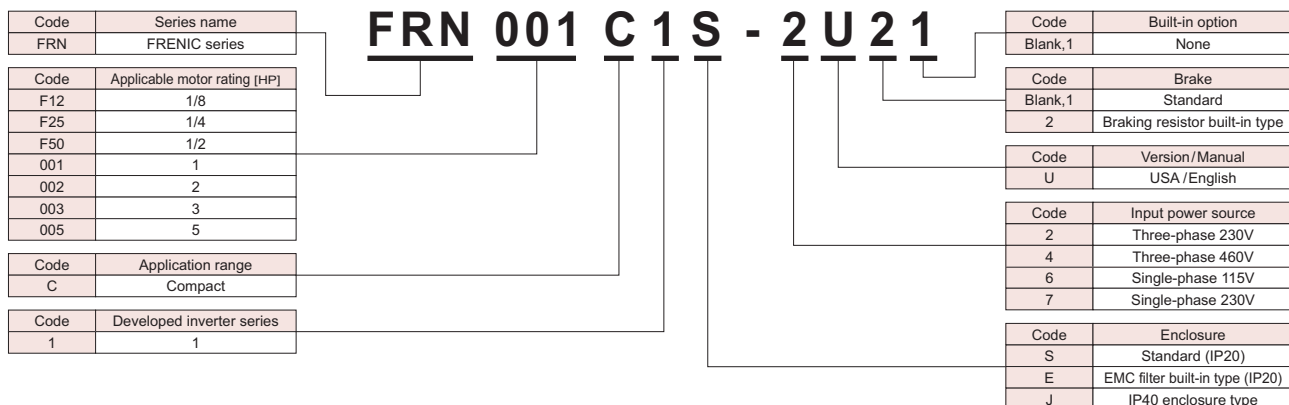

Note) If "Built-in option" is "None" and "Brake" is "Standard", the model numbers are indicated in the same format as those of the above standard specifications.

Standard Specifications

Standard specifications

The Compact Inverter **FRENIC-Mini**

Three-phase series

| Item | | Specifications | | | | | | | | | | | | | |
|------------------------------------|--------------------------------------|-------------------------|---|------------------|------------------|------------------|------------------|------------------|---|------------------|------------------|------------------|------------------|----------|------|
| Input power source | | Three-phase 230V | | | | | | Three-phase 460V | | | | | | | |
| Type (FRN□□□C1S-□U) | | FRNF12 C1S-2U | FRNF25 C1S-2U | FRNF50 C1S-2U | FRN001 C1S-2U | FRN002 C1S-2U | FRN003 C1S-2U | FRN005 C1S-2U | FRNF50 C1S-4U | FRN001 C1S-4U | FRN002 C1S-4U | FRN003 C1S-4U | FRN005 C1S-4U | | |
| Applicable motor rating *1) | | HP | 1/8 | 1/4 | 1/2 | 1 | 2 | 3 | 5 | 1/2 | 1 | 2 | 3 | 5 | |
| Output ratings | Rated capacity *2) | kVA | 0.31 | 0.59 | 1.1 | 1.9 | 3.1 | 4.3 | 6.7 | 1.1 | 1.9 | 2.9 | 4.3 | 7.1 | |
| | Rated voltage *3) | V | Three-phase, 200V/50Hz, 200, 220, 230V/60Hz | | | | | | Three-phase, 380, 400, 415V/50Hz, 380, 400, 440, 460V/60Hz | | | | | | |
| | Rated current *4) | A | 0.8 (0.7) | 1.5 (1.4) | 3.0 (2.5) | 5.0 (4.2) | 8.0 (7.0) | 11.0 (10.0) | 17.0 (16.5) | 1.5 | 2.5 | 3.7 | 5.5 | 9.0 | |
| | Overload capability | | 150% of rated current for 1min, 200% of rated current for 0.5s | | | | | | | | | | | | |
| | Rated frequency | | 50, 60Hz | | | | | | | | | | | | |
| Input ratings | Phases, voltage, frequency | | Three-phase, 200 to 240V, 50/60Hz | | | | | | Three-phase, 380 to 480V, 50/60Hz | | | | | | |
| | Voltage/frequency variations | | Voltage: +10 to -15% (Voltage unbalance *10) : 2% or less | | | | | | Frequency: +5 to -5% | | | | | | |
| | Momentary voltage dip capability *5) | | When the input voltage is 165V or more, the inverter continues operation. If it drops below 165V, the inverter operates for 15ms. | | | | | | When the input voltage is 300V or more, the inverter continues operation. If it drops below 300V, the inverter operates for 15ms. | | | | | | |
| | Rated current *6) | A | (with DCR) | 0.57 | 0.93 | 1.6 | 3.0 | 5.7 | 8.3 | 14.0 | 0.85 | 1.6 | 3.0 | 4.4 | 7.3 |
| | | | (without DCR) | 1.1 | 1.8 | 3.1 | 5.3 | 9.5 | 13.2 | 22.2 | 1.7 | 3.1 | 5.9 | 8.2 | 13.0 |
| Required power supply capacity *7) | | kVA | 0.2 | 0.3 | 0.6 | 1.1 | 2.0 | 2.9 | 4.9 | 0.6 | 1.1 | 2.0 | 2.9 | 4.9 | |
| Braking | Torque *8) | | % | | 150 | 100 | 50 | 30 | 100 | 50 | 30 | | | | |
| | Torque *9) | | % | | - | 150 | | | | 150 | | | | | |
| | DC injection braking | | Starting frequency: 0.0 to 60.0Hz Braking time: 0.0 to 30.0s Braking level: 0 to 100% of rated current | | | | | | | | | | | | |
| Enclosure (IEC 60529) | | IP20, UL open type *11) | | | | | | | | | | | | | |
| Cooling method | | Natural cooling | | | | | Fan cooling | | | Natural cooling | | Fan cooling | | | |
| Weight / Mass | | lbs.(kg) | 1.3(0.6) | 1.3(0.6) | 1.3(0.6) | 1.5(0.7) | 3.7(1.7) | 3.7(1.7) | 5.1(2.3) | 2.4(1.1) | 2.6(1.2) | 3.7(1.7) | 3.7(1.7) | 5.1(2.3) | |

Single-phase series

| Item | | Specifications | | | | | | | | | | | |
|------------------------------------|--------------------------------------|-------------------------|---|------------------|------------------|------------------|------------------|------------------------|---|------------------|------------------|----------|------|
| Input power source | | Single-phase 230V | | | | | | Single-phase 115V *12) | | | | | |
| Type (FRN□□□C1S-□U) | | FRNF12 C1S-7U | FRNF25 C1S-7U | FRNF50 C1S-7U | FRN001 C1S-7U | FRN002 C1S-7U | FRN003 C1S-7U | FRNF12 C1S-6U | FRNF25 C1S-6U | FRNF50 C1S-6U | FRN001 C1S-6U | | |
| Applicable motor rating *1) | | HP | 1/8 | 1/4 | 1/2 | 1 | 2 | 3 | 1/8 | 1/4 | 1/2 | 1 | |
| Output ratings | Rated capacity *2) | kVA | 0.31 | 0.59 | 1.1 | 1.9 | 3.1 | 4.3 | 0.26 | 0.53 | 0.95 | 1.6 | |
| | Rated voltage *3) | V | Three-phase, 200V/50Hz, 200, 220, 230V/60Hz | | | | | | | | | | |
| | Rated current *4) | A | 0.8 (0.7) | 1.5 (1.4) | 3.0 (2.5) | 5.0 (4.2) | 8.0 (7.0) | 11.0 (10.0) | 0.7 | 1.4 | 2.5 | 4.2 | |
| | Overload capability | | 150% of rated current for 1 min, 200% of rated current for 0.5s | | | | | | | | | | |
| | Rated frequency | | 50, 60Hz | | | | | | | | | | |
| Input ratings | Phases, voltage, frequency | | Single-phase, 200 to 240V, 50/60Hz | | | | | | Single-phase, 100 to 120V, 50/60Hz | | | | |
| | Voltage/frequency variations | | Voltage: +10 to -10% | | | | | | Frequency: +5 to -5% | | | | |
| | Momentary voltage dip capability *5) | | When the input voltage is 165V or more, the inverter continues operation. If it drops below 165V, the inverter operates for 15ms. | | | | | | When the input voltage is 85V or more, the inverter continues operation. If it drops below 85V, the inverter operates for 15ms. | | | | |
| | Rated current *6) | A | (with DCR) | 1.1 | 2.0 | 3.5 | 6.4 | 11.6 | 17.5 | 2.2 | 3.8 | 6.4 | 12.0 |
| | | | (without DCR) | 1.8 | 3.3 | 5.4 | 9.7 | 16.4 | 24.8 | 3.6 | 5.9 | 9.5 | 16.1 |
| Required power supply capacity *7) | | kVA | 0.3 | 0.4 | 0.7 | 1.3 | 2.4 | 3.5 | 0.3 | 0.5 | 0.7 | 1.3 | |
| Braking | Torque *8) | | % | | 150 | 100 | 50 | 30 | 150 | 100 | | | |
| | Torque *9) | | % | | - | 150 | | | | - | 150 | | |
| | DC injection braking | | Starting frequency: 0.0 to 60.0Hz Braking time: 0.0 to 30.0s Braking level: 0 to 100% of rated current | | | | | | | | | | |
| Enclosure (IEC 60529) | | IP20, UL open type *11) | | | | | | IP20 | | | | | |
| Cooling method | | Natural cooling | | | | | Fan cooling | | | Natural cooling | | | |
| Weight / Mass | | lbs.(kg) | 1.3(0.6) | 1.3(0.6) | 1.3(0.6) | 1.8(0.8) | 3.7(1.7) | 5.1(2.3) | 1.3(0.6) | 1.3(0.6) | 1.5(0.7) | 2.6(1.2) | |

*1) Standard 4-pole motor

*2) Rated capacity is calculated by regarding the output rated voltage as 220V for three-phase 230V and single-phase 230V series, and as 440V for three-phase 460V series.

*3) Output voltage cannot exceed the power supply voltage.

*4) Use the inverter at the current given in () or below when the carrier frequency setting is higher than 4kHz (F2S:4 to 5) or the ambient temperature is 40°C (104°F) or higher.

*5) Tested under the standard load condition (85% load for nominal applied motor).

*6) Calculated under Fuji-specified conditions.

*7) Obtained when a DC REACTOR (option) is used.

*8) Average braking torque obtained with AVR control OFF (Varies with the efficiency of the motor.)

*9) Average braking torque obtained by use of external braking resistor (standard type available as option)



EMC filter built-in type

The Compact Inverter FRENIC-Mini

Three-phase series

| Item | | Specifications | | | | | | | | | | | | | | | | |
|------------------------------------|--------------------------------------|-------------------------|---|---------------|---------------|---------------|---------------|------------------|---|---------------|-----------------|---------------|---------------|-------------|------|--|----|--|
| Input power source | | Three-phase 230V | | | | | | Three-phase 460V | | | | | | | | | | |
| Type (FRN□□□C1E-□U) | | FRNF12 C1E-2U | FRNF25 C1E-2U | FRNF50 C1E-2U | FRN001 C1E-2U | FRN002 C1E-2U | FRN003 C1E-2U | FRN005 C1E-2U | FRNF50 C1E-4U | FRN001 C1E-4U | FRN002 C1E-4U | FRN003 C1E-4U | FRN005 C1E-4U | | | | | |
| Applicable motor rating *1) | | HP | 1/8 | 1/4 | 1/2 | 1 | 2 | 3 | 5 | 1/2 | 1 | 2 | 3 | 5 | | | | |
| Output ratings | Rated capacity *2) | kVA | 0.31 | 0.59 | 1.1 | 1.9 | 3.1 | 4.3 | 6.7 | 1.1 | 1.9 | 2.9 | 4.3 | 7.1 | | | | |
| | Rated voltage *3) | V | Three-phase, 200V/50Hz, 200, 220, 230V/60Hz | | | | | | Three-phase, 380, 400, 415V/50Hz, 380, 400, 440, 460V/60Hz | | | | | | | | | |
| | Rated current *4) | A | 0.8 (0.7) | 1.5 (1.4) | 3.0 (2.5) | 5.0 (4.2) | 8.0 (7.0) | 11.0 (10.0) | 17.0 (16.5) | 1.5 | 2.5 | 3.7 | 5.5 | 9.0 | | | | |
| | Overload capability | | 150% of rated current for 1min, 200% of rated current for 0.5s | | | | | | | | | | | | | | | |
| | Rated frequency | | 50, 60Hz | | | | | | | | | | | | | | | |
| Input ratings | Phases, voltage, frequency | | Three-phase, 200 to 240V, 50/60Hz | | | | | | Three-phase, 380 to 480V, 50/60Hz | | | | | | | | | |
| | Voltage/frequency variations | | Voltage: +10 to -15% (Voltage unbalance *10) : 2% or less | | | | | | Frequency: +5 to -5% | | | | | | | | | |
| | Momentary voltage dip capability *5) | | When the input voltage is 165V or more, the inverter continues operation. If it drops below 165V, the inverter operates for 15ms. | | | | | | When the input voltage is 300V or more, the inverter continues operation. If it drops below 300V, the inverter operates for 15ms. | | | | | | | | | |
| | Rated current *6) | A | (with DCR) | 0.57 | 0.93 | 1.6 | 3.0 | 5.7 | 8.3 | 14.0 | 0.85 | 1.6 | 3.0 | 4.4 | 7.3 | | | |
| | | | (without DCR) | 1.1 | 1.8 | 3.1 | 5.3 | 9.5 | 13.2 | 22.2 | 1.7 | 3.1 | 5.9 | 8.2 | 13.0 | | | |
| Required power supply capacity *7) | | kVA | 0.2 | 0.3 | 0.6 | 1.1 | 2.0 | 2.9 | 4.9 | 0.6 | 1.1 | 2.0 | 2.9 | 4.9 | | | | |
| Braking | Torque *8) | | % | | 150 | | 100 | | 50 | | 30 | | 100 | | 50 | | 30 | |
| | Torque *9) | | % | | - | | 150 | | 150 | | | | | | | | | |
| | DC injection braking | | Starting frequency: 0.0 to 60.0Hz Braking time: 0.0 to 30.0s Braking level: 0 to 100% of rated current | | | | | | | | | | | | | | | |
| Enclosure (IEC 60529) | | IP20, UL open type *11) | | | | | | | | | | | | | | | | |
| Cooling method | | Natural cooling | | | | | | Fan cooling | | | Natural cooling | | | Fan cooling | | | | |
| Weight / Mass | | lbs.(kg) | 1.5(0.7) | 1.5(0.7) | 1.5(0.7) | 1.8(0.8) | 5.3(2.4) | 5.3(2.4) | 6.4(2.9) | 3.3(1.5) | 3.7(1.6) | 5.5(2.5) | 5.5(2.5) | 6.6(3.0) | | | | |

Single-phase series

| Item | | Specifications | | | | | | | | | | |
|------------------------------------|--------------------------------------|-------------------------|---|---------------|---------------|---------------|---------------|-------------|------|--|----|--|
| Input power source | | Single-phase 230V | | | | | | | | | | |
| Type (FRN□□□C1E-□U) | | FRNF12 C1E-7U | FRNF25 C1E-7U | FRNF50 C1E-7U | FRN001 C1E-7U | FRN002 C1E-7U | FRN003 C1E-7U | | | | | |
| Applicable motor rating *1) | | HP | 1/8 | 1/4 | 1/2 | 1 | 2 | 3 | | | | |
| Output ratings | Rated capacity *2) | kVA | 0.31 | 0.59 | 1.1 | 1.9 | 3.1 | 4.3 | | | | |
| | Rated voltage *3) | V | Three-phase, 200V/50Hz, 200, 220, 230V/60Hz | | | | | | | | | |
| | Rated current *4) | A | 0.8 (0.7) | 1.5 (1.4) | 3.0 (2.5) | 5.0 (4.2) | 8.0 (7.0) | 11.0 (10.0) | | | | |
| | Overload capability | | 150% of rated current for 1min, 200% of rated current for 0.5s | | | | | | | | | |
| | Rated frequency | | 50, 60Hz | | | | | | | | | |
| Input ratings | Phases, voltage, frequency | | Single-phase, 200 to 240V, 50/60Hz | | | | | | | | | |
| | Voltage/frequency variations | | Voltage: +10 to -10%, Frequency: +5 to -5% | | | | | | | | | |
| | Momentary voltage dip capability *5) | | When the input voltage is 165V or more, the inverter continues operation. If it drops below 165V, the inverter operates for 15ms. | | | | | | | | | |
| | Rated current *6) | A | (with DCR) | 1.1 | 2.0 | 3.5 | 6.4 | 11.6 | 17.5 | | | |
| | | | (without DCR) | 1.8 | 3.3 | 5.4 | 9.7 | 16.4 | 24.8 | | | |
| Required power supply capacity *7) | | kVA | 0.3 | 0.4 | 0.7 | 1.3 | 2.4 | 3.5 | | | | |
| Braking | Torque *8) | | % | | 150 | | 100 | | 50 | | 30 | |
| | Torque *9) | | % | | - | | 150 | | | | | |
| | DC injection braking | | Starting frequency: 0.0 to 60.0Hz Braking time: 0.0 to 30.0s Braking level: 0 to 100% of rated current | | | | | | | | | |
| Enclosure (IEC 60529) | | IP20, UL open type *11) | | | | | | | | | | |
| Cooling method | | Natural cooling | | | | | | Fan cooling | | | | |
| Weight / Mass | | lbs.(kg) | 1.5(0.7) | 1.5(0.7) | 1.5(0.7) | 2.6(1.2) | 5.3(2.4) | 6.4(2.9) | | | | |

*10) Voltage unbalance [%] = $\frac{\text{Max voltage [V]} - \text{Min voltage [V]}}{\text{Three-phase average voltage [V]}} \times 67$ (IEC 61800-3 (5.2.3))

If this value is 2 to 3%, use AC REACTOR (ACR).

*11) NEMA1 kit (option) is required for the enclosure conforming to the UL standard TYPE1 (NEMA1). Use the inverter in the ambient temperature range from -10 to +40°C (14 to 104°F).

*12) When driven by 100 VAC, the single-phase 115 V class series of inverters limit their shaft output and maximum output torque as listed below. This is to prevent their output voltage from decreasing when load is applied.

| | Shaft output (%) | Maximum torque (%) |
|----------------------|------------------|--------------------|
| w/o DC reactor (DCR) | 90 | 150 |
| w/ DC reactor (DCR) | 85 | 120 |

Semi-standard Specifications

Braking resistor built-in type

The Compact Inverter **FRENIC-Mini**

| Item | | Specifications | | | | | | | |
|------------------------------------|--------------------------------------|--------------------|---|--|--------------------|---|--------------------|----------|------|
| Input power source | | Three-phase 230V | | | Three-phase 460V | | | | |
| Type (FRN□□□C1S-□U21) | | FRN002 C1S-2U21 | FRN003 C1S-2U21 | FRN005 C1S-2U21 | FRN002 C1S-4U21 | FRN003 C1S-4U21 | FRN005 C1S-4U21 | | |
| Applicable motor rating *1) | | HP | 2 | 3 | 5 | 2 | 3 | 5 | |
| Output ratings | Rated capacity *2) | kVA | 3.1 | 4.3 | 6.7 | 2.9 | 4.3 | 7.1 | |
| | Rated voltage *3) | V | Three-phase, 200V/50Hz, 200, 220, 230V/60Hz | | | Three-phase, 380, 400, 415V/50Hz, 380, 400, 440, 460V/60Hz | | | |
| | Rated current *4) | A | 8.0 (7.0) | 11.0 (10.0) | 17.0 (16.5) | 3.7 | 5.5 | 9.0 | |
| | Overload capability | | 150% of rated current for 1min, 200% of rated current for 0.5s | | | | | | |
| | Rated frequency | | 50, 60Hz | | | | | | |
| Input ratings | Phases, voltage, frequency | | Three-phase, 200 to 240V, 50/60Hz | | | Three-phase, 380 to 480V, 50/60Hz | | | |
| | Voltage/frequency variations | | Voltage: +10 to -15% (Voltage unbalance *10) : 2% or less | | | Frequency: +5 to -5% | | | |
| | Momentary voltage dip capability *5) | | When the input voltage is 165V or more, the inverter continues operation. If it drops below 165V, the inverter operates for 15ms. | | | When the input voltage is 300V or more, the inverter continues operation. If it drops below 300V, the inverter operates for 15ms. | | | |
| | Rated current *6) | (with DCR) | A | 5.7 | 8.3 | 14.0 | 3.0 | 4.4 | 7.3 |
| | | (without DCR) | A | 9.5 | 13.2 | 22.2 | 5.9 | 8.2 | 13.0 |
| Required power supply capacity *7) | | kVA | 2.0 | 2.9 | 4.9 | 2.0 | 2.9 | 4.9 | |
| Braking | Torque *8) | | % | 150 | 100 | 100 | 150 | 100 | 100 |
| | Braking time | | s | 18 | 12 | 8 | 18 | 12 | 8 |
| | Duty cycle | | % | 3 | 2 | 1.5 | 3 | 2 | 1.5 |
| | DC injection braking | | | Starting frequency: 0.0 to 60.0Hz Braking time: 0.0 to 30.0s Braking level: 0 to 100% of rated current | | | | | |
| Enclosure (IEC 60529) | | | IP20, UL open type *11) | | | | | | |
| Cooling method | | | Fan cooling | | | | | | |
| Weight / Mass | | lbs.(kg) | 4.0(1.8) | 4.0(1.8) | 5.5(2.5) | 4.0(1.8) | 4.0(1.8) | 5.5(2.5) | |

IP40 enclosure type

The Compact Inverter **FRENIC-Mini**

| Item | | Specifications | | | | | | | | | | | | | |
|------------------------------------|--------------------------------------|------------------|---|--|------------------|------------------|------------------|------------------|---|------------------|------------------|------------------|------------------|----------|------|
| Input power source | | Three-phase 230V | | | | | | Three-phase 460V | | | | | | | |
| Type (FRN□□□C1J-□U) | | FRNF12 C1J-2U | FRNF25 C1J-2U | FRNF50 C1J-2U | FRN001 C1J-2U | FRN002 C1J-2U | FRN003 C1J-2U | FRN005 C1J-2U | FRNF50 C1J-2U | FRN001 C1J-2U | FRN002 C1J-2U | FRN003 C1J-2U | FRN005 C1J-2U | | |
| Applicable motor rating *1) | | HP | 1/8 | 1/4 | 1/2 | 1 | 2 | 3 | 5 | 1/2 | 1 | 2 | 3 | 5 | |
| Output ratings | Rated capacity *2) | kVA | 0.31 | 0.59 | 1.1 | 1.9 | 3.1 | 4.3 | 6.7 | 1.1 | 1.9 | 2.9 | 4.3 | 7.1 | |
| | Rated voltage *3) | V | Three-phase, 200V/50Hz, 200, 220, 230V/60Hz | | | | | | Three-phase, 380, 400, 415V/50Hz, 380, 400, 440, 460V/60Hz | | | | | | |
| | Rated current | A | High carrier (4-15kHz) | 0.7 | 1.4 | 2.5 | 4.2 | 7.0 | 10.0 | 16.5 | 1.5 | 2.5 | 3.7 | 5.5 | 9.0 |
| | | | Low carrier (-3kHz) | 0.8 | 1.5 | 3.0 | 5.0 | 8.0 | 11.0 | 17.0 | | | | | |
| | Overload capability | | 150% of rated current for 1min, 200% of rated current for 0.5s | | | | | | | | | | | | |
| Rated frequency | | 50, 60Hz | | | | | | | | | | | | | |
| Input ratings | Phases, voltage, frequency | | Three-phase, 200 to 240V, 50/60Hz | | | | | | Three-phase, 380 to 480V, 50/60Hz | | | | | | |
| | Voltage/frequency variations | | Voltage: +10 to -15% (Voltage unbalance : 2% or less *10)) | | | | | | Frequency: +5 to -5% | | | | | | |
| | Momentary voltage dip capability *5) | | When the input voltage is 165V or more, the inverter continues operation. If it drops below 165V, the inverter operates for 15ms. | | | | | | When the input voltage is 300V or more, the inverter continues operation. If it drops below 300V, the inverter operates for 15ms. | | | | | | |
| | Rated input current *6) | (with DCR) | A | 0.57 | 0.93 | 1.6 | 3.0 | 5.7 | 8.3 | 14.0 | 0.85 | 1.6 | 3.0 | 4.4 | 7.3 |
| | | (without DCR) | A | 1.1 | 1.8 | 3.1 | 5.3 | 9.5 | 13.2 | 22.2 | 1.7 | 3.1 | 5.9 | 8.2 | 13.0 |
| Required power supply capacity *7) | | kVA | 0.2 | 0.3 | 0.6 | 1.1 | 2.0 | 2.9 | 4.9 | 0.6 | 1.1 | 2.0 | 2.9 | 4.9 | |
| Braking | Torque *8) | | % | 150 | 100 | 50 | 30 | 100 | 50 | 30 | 100 | 50 | 30 | | |
| | Torque *9) | | % | - | 150 | | | 150 | | | | | | | |
| | DC injection braking | | % | Starting frequency: 0.0 to 60.0Hz Braking time: 0.0 to 30.0s Braking level: 0 to 100% of rated current | | | | | | | | | | | |
| Applicable safety standards | | | UL508C, C22.2No.14, EN50178:1997 or equivalent | | | | | | | | | | | | |
| Enclosure (IEC 60529) | | | IP 40 | | | | | | | | | | | | |
| Cooling method | | | Natural cooling | | | | Fan cooling | | | Natural cooling | | Fan cooling | | | |
| Weight / Mass | | lbs.(kg) | 1.5(0.7) | 1.5(0.7) | 1.5(0.7) | 1.8(0.8) | 4.8(1.8) | 4.8(1.8) | 5.3(2.4) | 2.6(1.2) | 2.9(1.3) | 4.0(1.8) | 4.0(1.8) | 5.3(2.4) | |

*1) Standard 4-pole motor

*2) Rated capacity is calculated by regarding the output rated voltage as 220V for three-phase 230V series, and as 440V for three-phase 460V series.

*3) Output voltage cannot exceed the power supply voltage.

*4) Use the inverter at the current given in () or below when the carrier frequency setting is higher than 4kHz (F25:4 to 15) or the ambient temperature is 40°C (104°F) or higher.

*5) Calculated under the standard overload conditions by JEMA committee (about 85% of overload by the standard applicable motor.)

*6) Calculated under Fuji-specified conditions.

*7) Obtained when a DC reactor (DCR) is used.

*8) Average braking torque obtained with AVR control OFF (Varies with the efficiency of the motor.)

*9) Average braking torque obtained by use of external braking resistor (optional)

*10) Voltage unbalance [%] = $\frac{\text{Max voltage [V]} - \text{Min voltage [V]}}{\text{Three-phase average voltage [V]}} \times 67$ (Refer to IEC 61800-3.)
If this value is 2 to 3%, use AC reactor (option).

*11) NEMA1 kit (option) is required for the enclosure conforming to the UL standard TYPE1 (NEMA1). Use the inverter in the ambient temperature range from -10 to +40°C (14 to 104°F).

Common specifications

 The Compact Inverter **FRENIC-Mini**

| Item | | Explanation | Remarks | Related function code |
|--|---|---|---|--|
| Output frequency | Setting range | Maximum frequency | 25 to 400Hz | For operation at 120Hz or more, test the inverter in advance by combining it with the motor. F03 |
| | | Base frequency | 25 to 400Hz | For operation at 120Hz or more, test the inverter in advance by combining it with the motor. F04 |
| | | Starting frequency | 0.1 to 60.0Hz | F23 |
| | | Carrier frequency | 0.75 to 15kHz | Frequency may drop automatically to protect the inverter running at 7kHz or more. This protective operation can be canceled by function code H98. F26,F27 H98 |
| | Accuracy(Stability) | Analog setting: $\pm 0.2\%$ of maximum frequency (at $25\pm 10^{\circ}\text{C}$ ($77\pm 50^{\circ}\text{F}$)) Digital setting: $\pm 0.01\%$ of maximum frequency (at -10 to $+50^{\circ}\text{C}$ (14 to 122°F)) | | |
| | Setting resolution | Analog setting: $1/1000$ of maximum frequency (ex. 0.06Hz at 60Hz, 0.4Hz at 400Hz) Keypad setting: 0.01Hz (99.99Hz or less), 0.1Hz (100.0Hz or more) Link setting: Selectable from 2 types • $1/2000$ of maximum frequency (ex. 0.003Hz at 60Hz, 0.02Hz at 400Hz) • 0.01Hz (fixed) | Includes the potentiometer on the keypad. Setting with keys. | |
| Control | Control method | V/f control (Simplified torque-vector control) | | |
| | Voltage/freq. characteristic (Non-linear V/f setting) | • Possible to set output voltage at base frequency and at maximum output frequency (common spec). • AVR control can be turned ON or OFF (Factory setting: OFF). | Three-phase 230V, single-phase 230V: 80 to 240V Three-phase 460V: 160 to 500V | F03 to F05 |
| | | 1 point (Desired voltage and frequency can be set.) | | H50,H51 |
| | Torque boost (Load selection) | Torque boost can be set with the function code F09. Select application load type with the function code F37. 0: Variable torque load 1: Constant torque load 2: Auto torque boost 3: Auto energy-save operation (variable torque load in acceleration/deceleration) 4: Auto energy-save operation (constant torque load in acceleration/deceleration) 5: Auto energy-save operation (auto torque boost in acceleration/deceleration) | Set when 0, 1, 3, or 4 is selected at F37. | F09,F37 F09,F37 |
| | | Starting torque | 150% or over (Auto torque boost in 5Hz operation) | |
| | Start/stop | Keypad operation: Start (FWD/REV) and stop with keys | Remote keypad (option) is also usable. | F02 |
| | | External signals (5 digital inputs): FWD, REV, coast to stop command, etc. | | |
| | | Link operation: Communication via RS-485 | RS-485 communication function is optional. | H30,y01 to y10 y99 |
| | Frequency setting | Can be set with built-in potentiometer (standard) Can be set with or key | Remote keypad (option) is also usable. | F01, C30 |
| | | Can be set with external potentiometer (1 to 5k Ω) | • Connected to analog input terminals 13, 12, 11. • Potentiometer must be provided. | F01, C30 |
| | | Analog input | • Can be set with external voltage/current output • 0 to +10V DC (0 to +5V DC)/0 to 100% (terminal 12) • +4 to +20mA DC/0 to 100% (terminal C1) | F18,C32 to C34 F18,C37 to C39 |
| | | (Inverse operation) | • Can be reversed with digital input signal (IVS) • +10 to 0V DC (+5 to 0V DC)/0 to 100% (terminal 12) • +20 to +4mA DC/0 to 100% (terminal C1) | E01 to E03 E98,E99 |
| | | Multistep frequency: Selectable from 8 steps (step 0 to 7) | | C05 to C11 |
| Link operation: Can be set with communication via RS-485 | | RS-485 communication function is optional. | H30,y01 to y10 | |
| Running status signal | Transistor output (1 point) : RUN, FAR, FDT, LU, etc. | | E20 | |
| | Relay output (1 point) : Alarm relay output or multipurpose relay output signal | | | |
| | Analog output (1 point) : Output frequency, output current, output voltage, input power, etc. | | F30,F31 | |
| Acceleration/ deceleration time (Pattern) | 0.00 to 3600s *If 0.00s is set, the time setting is cancelled and acceleration and deceleration is made according to the pattern given with an external signal. | | F07,F08 | |
| | Acceleration and deceleration time can be independently set and selected with digital input signal (1 point). | | E10,E11 | |
| | Acceleration and deceleration pattern can be selected from 4 types: Linear, S-curve (weak), S-curve (strong), Non-linear | | H07 | |
| Frequency limiter | High and Low limiters can be set. | | F15 F16 | |
| Bias frequency | Bias of set frequency and PID command can be independently set. | | F18 C50 to C52 | |
| Gain for frequency setting | Proportional relation between analog input signal and output frequency can be set. Ex. When voltage input signal is between 0 and +5V DC, the inverter can be used at +5V DC/max output frequency by setting gain to 200%. | Voltage signal (terminal 12) and current signal (terminal C1) can be set independently. | C32 to C39 | |
| Jump frequency control | 3 operation points and their common jump hysteresis width (0 to 30Hz) can be set. | | C01 to C04 | |
| Jogging operation | • Can be operated using digital input signal or keypad. • Acceleration and deceleration time (same duration used only for jogging) can be set. • Jogging frequency: 0.00 to 400.0Hz | | H54 C20 | |
| Timer operation | Operation starts and stops at the time set from keypad (1 cycle). | | C21 | |
| Auto-restart after momentary power failure | Restarts the inverter without stopping the motor after instantaneous power failure. | | F14 | |
| Slip compensation | Compensates for decrease in speed according to the load, enabling stable operation. | | P09 | |
| Current limit | Keeps the current under the preset value during operation. | | F43,F44 | |

Common Specifications

Common specifications

The Compact Inverter **FRENIC-Mini**

| Item | Explanation | Remarks | Related function code | | | | | | | | | |
|----------------------------------|--|--|---|---|---------------------------|------|----------------------------------|-----------|----------------------------------|------------|---|--|
| Control | PID control | PID control is possible using analog input signals. Inverse operation can be set using digital input signal (IVS) or the function code J01. Process commands ⬆️, ⬇️ key operation: Set frequency[Hz]/Max frequency[Hz] x100[%] Built-in potentiometer • Voltage input (terminal 12) : 0 to +10V DC/0 to 100% • Current input (terminal C1) : +4 to +20mA DC/0 to 100% • RS-485 communication : Set frequency[Hz]/Max frequency[Hz] x100[%] Feedback signal • Voltage input (terminal 12) : 0 to 10V DC/0 to 100% • Current input (terminal C1) : +4 to +20mA DC/0 to 100% | Select the control mode with J01. Select the kind of remote process command with J02, E60 to E62. | J01 J02 E60 E61 E62 J02 | | | | | | | | |
| | Automatic deceleration | Makes the deceleration time 3 times longer to avoid OU trip when DC link circuit voltage exceeds the overvoltage limit. (Set at the function code H69 : 1.) | • Trip may occur even when deceleration time is prolonged if the moment of inertia is large. • This function does not come ON during constant speed operation. | H69 | | | | | | | | |
| | Overload prevention control | Prevents tripping before the inverter becomes overloaded. | | H70 | | | | | | | | |
| | Energy saving operation | • Minimizes motor losses at light load. • Can be set in accordance with the kind of load (variable torque load, constant torque load, auto torque boost). | | F37 | | | | | | | | |
| | Fan stop operation | Detects inverter internal temperature and stops cooling fan when the temperature is low. | | H06 | | | | | | | | |
| Indication | Running | • Speed monitor, output current [A], output voltage [V], input power [kW], PID reference, PID feedback value ♦Select the speed monitor to be displayed from the following: • Output frequency (before slip compensation) [Hz], output frequency (after slip compensation) [Hz], set frequency [Hz], Load shaft speed [r/min], line speed [m/min], constant rate of feeding time [min]. | Speed monitor can display the speed set at E48. | E43 E48 | | | | | | | | |
| | Stopping | Displays the same contents as displayed during running. | Same as above | Same as above | | | | | | | | |
| | Trip mode | Displays the cause of trip by codes as follows. OC1 : Overcurrent during acceleration OC2 : Overcurrent during deceleration OC3 : Overcurrent at constant speed Lin : Input phase loss LU : Undervoltage OPL : Output phase loss OU1 : Overvoltage during acceleration OU2 : Overvoltage during deceleration OU3 : Overvoltage during constant speed OH1 : Overheating of the heat sink OH2 : External thermal relay tripped OH4 : Motor protection (PTC thermistor) dbH : Overheating of the DB circuit OL1 : Motor overload OLU : Inverter unit overload Er1 : Memory error Er2 : KEYPAD communication error Er3 : CPU error Er6 : Operation procedure error Er8 : RS485 error ErF : Data save error due to undervoltage | For details, refer to the protective functions (p.22). | | | | | | | | | |
| | Running or trip mode | Trip history: Saves and displays the last 4 trip codes and their detailed description. (Even with the main power off, trip history data of the last 4 trips are retained.) | For details, refer to the instruction manual or FRENIC-Mini User's Manual. | | | | | | | | | |
| Protection | Overcurrent (Short-circuit) (Ground fault) | Protects and stops the inverter when the following overcurrent flows during acceleration, deceleration, or constant speed rotation: • Overcurrent caused by overload • Overcurrent caused by short-circuit in output circuit • Overcurrent caused by ground fault | Ground fault can be detected at starting. | | | | | | | | | |
| | Overvoltage | Stops the inverter by detecting overvoltage in DC link circuit during braking. | 230V series: 400V DC 460V series: 800V DC | | | | | | | | | |
| | Incoming surge | Protects the inverter from surge voltage entering between main circuit power cable and earth cable. | | | | | | | | | | |
| | Undervoltage | Stops the inverter by detecting voltage drop in DC link circuit. | 230V series: 200V DC 460V series: 400V DC Details of operation can be selected with the function code F14. | F14 | | | | | | | | |
| | Input phase loss | Stops or protects the inverter against input phase loss. | Non-operation is also selectable. | H98 | | | | | | | | |
| | Output phase loss | Detects breaks in inverter output wiring at the start of running and during running, stopping the inverter output. | Non-operation is also selectable. | H98 | | | | | | | | |
| | Overheating (Heat sink) (Braking resistor) | Stops the inverter by detecting inverter heat sink temperature. Stops the inverter and built-in braking transistor if "discharging capability" or "average allowable loss" set for the braking resistor is exceeded more frequently than the set number of times. | | F50,F51 | | | | | | | | |
| | Overload | Stops the inverter by detecting the output current and internal temp. To calculate the IGBT internal temp. | | | | | | | | | | |
| | Motor protection | (Electronic thermal) (PTC thermistor) | Stops the inverter to protect the motor when the set output. Current is exceeded. A PTC thermistor input stops the inverter to protect the motor. | Thermal time constant can be adjusted (0.5 to 75.0min). | F10 to F12 H26,H27 | | | | | | | |
| | | (Overload early warning) | Warning signal can be output based on the set level before the inverter trips. | Related transistor output: OL | E34,E35 | | | | | | | |
| Retry function | When the motor is tripped and stopped, this function automatically resets the tripping state and restarts operation. Activated when the motor is tripped with the following trip codes: OC1, OC2, OC3, OU1, OU2, OU3, OH1, OH4, dbH, OL, OLU | Waiting time before resetting and the number of retry times can be set. | H04,H05 | | | | | | | | | |
| Installation location | Shall be free from corrosive gases, flammable gases, oil mist, dusts, and direct sunlight. Indoor use only. | Pollution degree 2 when the Low Voltage Directives are used. | | | | | | | | | | |
| Ambient temperature | -10 to +50°C (14 to 122°F) | -10 to 40°C (14 to 104°F) when inverters are installed side by side without clearance. | | | | | | | | | | |
| Ambient humidity | 5 to 95%RH (no condensation) | | | | | | | | | | | |
| Environment | Altitude | <table border="1"> <thead> <tr> <th>Altitude</th> <th>Output derating</th> </tr> </thead> <tbody> <tr> <td>3281 ft (1000 m) or lower</td> <td>None</td> </tr> <tr> <td>3284 to 6562 ft (1001 to 2000 m)</td> <td>Decreases</td> </tr> <tr> <td>6565 to 9843 ft (2001 to 3000 m)</td> <td>Decreases*</td> </tr> </tbody> </table> | Altitude | Output derating | 3281 ft (1000 m) or lower | None | 3284 to 6562 ft (1001 to 2000 m) | Decreases | 6565 to 9843 ft (2001 to 3000 m) | Decreases* | * If the altitude exceeds 6562 ft (2000 m), insulate the interface circuit from the main power supply to conform to the Low Voltage Directives. | |
| | Altitude | Output derating | | | | | | | | | | |
| | 3281 ft (1000 m) or lower | None | | | | | | | | | | |
| 3284 to 6562 ft (1001 to 2000 m) | Decreases | | | | | | | | | | | |
| 6565 to 9843 ft (2001 to 3000 m) | Decreases* | | | | | | | | | | | |
| Vibration | 3mm (vibration width): 2 to less than 9Hz, 9.8m/s ² : 9 to less than 20Hz 2m/s ² : 20 to less than 55Hz, 1m/s ² : 55 to less than 200Hz | | | | | | | | | | | |
| Storage | Amb. temp. -25 to +70°C (-13 to +158°F) Amb. humidity 5 to 95%RH (no condensation) | | | | | | | | | | | |

Without EMC filter type

Fig. 1

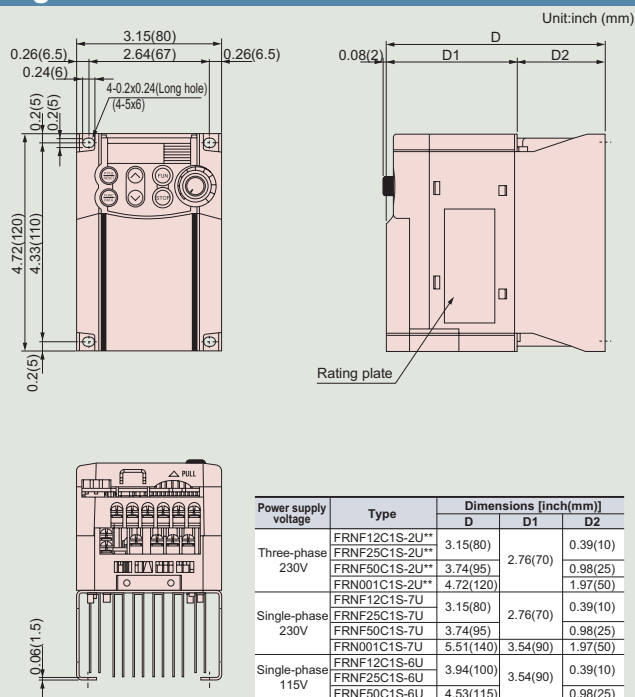

Fig. 2

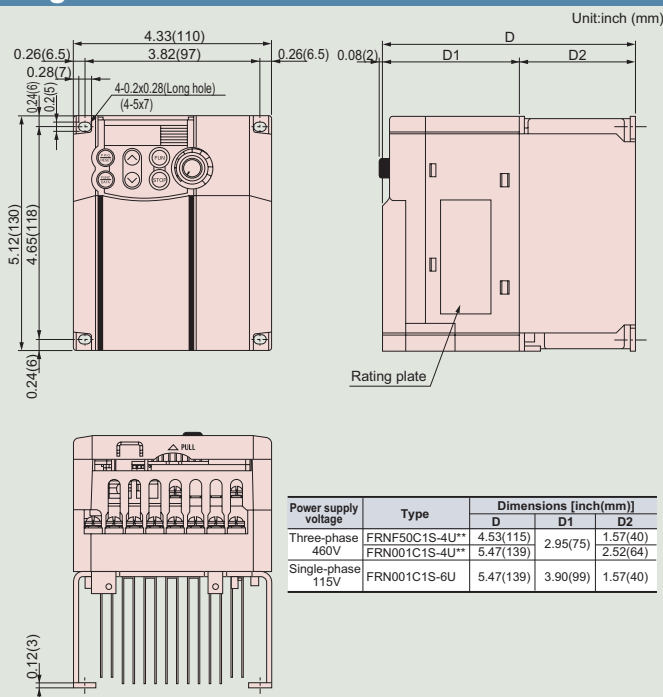

Fig. 3

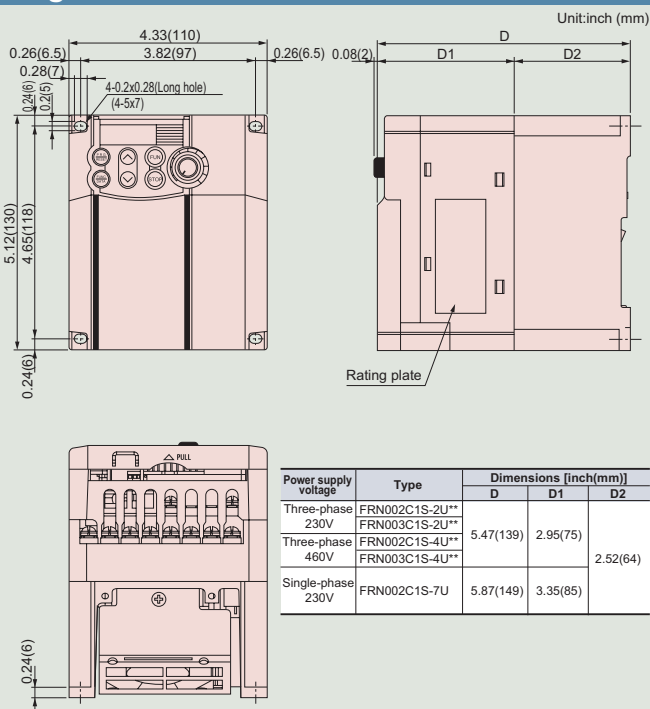
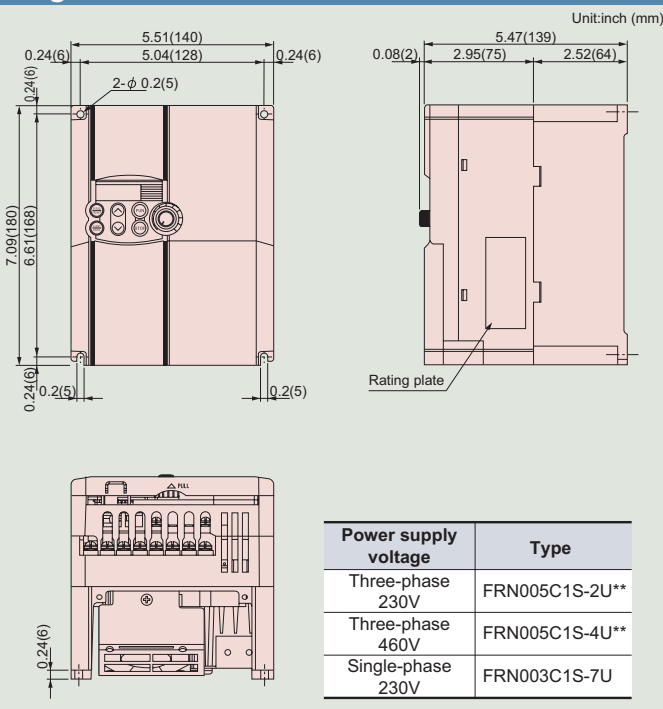

Fig. 4



Note) • The symbols ** followed by the inverter type FRN□□□C1S-2U represent the following numeral codes:
21 (Braking resistor built-in type), None (Standard)

External Dimensions

EMC filter built-in type

Fig. 1

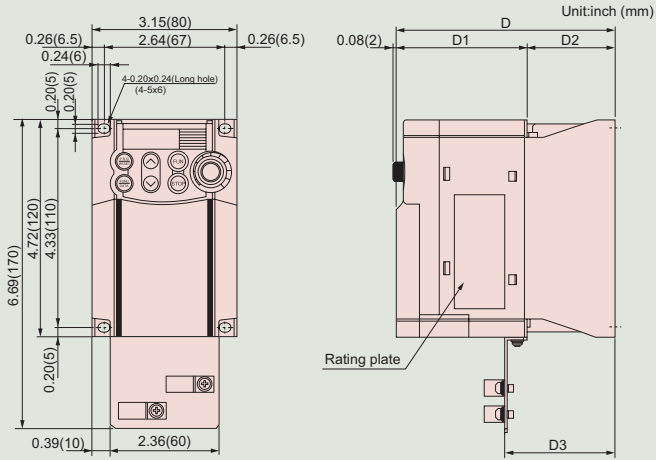

| Power supply voltage | Type | Dimensions [inch(mm)] | | | |
|----------------------|--------------|-----------------------|----------|------------|------------|
| | | D | D1 | D2 | D3 |
| Three-phase 230V | FRNF12C1E-2U | 3.94(100) | 3.54(90) | 0.39(10) | 0.83(21.2) |
| | FRNF25C1E-2U | 4.53(115) | | | |
| | FRNF50C1E-2U | 5.51(140) | 0.98(25) | 1.43(36.2) | |
| | FRN001C1E-2U | 5.51(140) | 1.97(50) | 2.41(61.2) | |
| Single-phase 230V | FRNF12C1E-7U | 3.94(100) | 3.54(90) | 0.39(10) | 0.83(21.2) |
| | FRNF25C1E-7U | 4.53(115) | | | |
| | FRNF50C1E-7U | 4.53(115) | 0.98(25) | 1.43(36.2) | |

Fig. 2

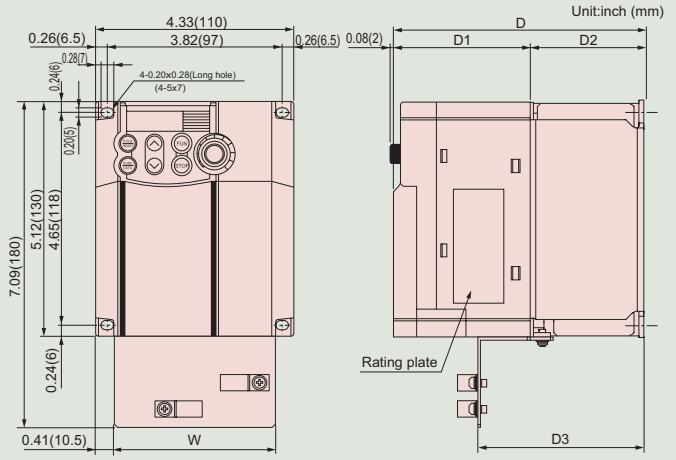

| Power supply voltage | Type | Dimensions [inch(mm)] | | | |
|----------------------|--------------|-----------------------|-----------|------------|------------|
| | | W | D | D1 | D3 |
| Three-phase 460V | FRNF50C1E-4U | 3.50(89) | 6.22(158) | 4.65(118) | 2.42(61.5) |
| | FRN001C1E-4U | 7.17(182) | 2.52(64) | 3.37(85.5) | |
| Single-phase 230V | FRN001C1E-7U | 2.36(60) | 5.47(139) | 3.90(99) | 2.17(55.2) |

Fig. 3

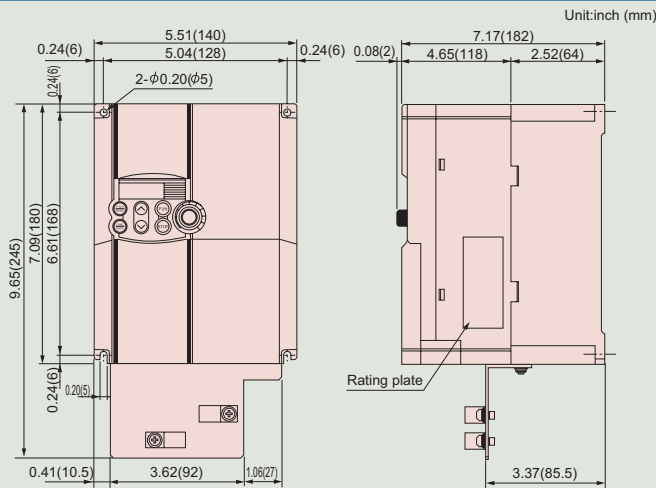

| Power supply voltage | Type |
|----------------------|--------------|
| Three-phase 230V | FRN002C1E-2U |
| | FRN003C1E-2U |
| | FRN005C1E-2U |
| Three-phase 460V | FRN002C1E-4U |
| | FRN003C1E-4U |
| | FRN005C1E-4U |
| Single-phase 230V | FRN002C1E-7U |
| | FRN003C1E-7U |

IP40 enclosure type

Fig.

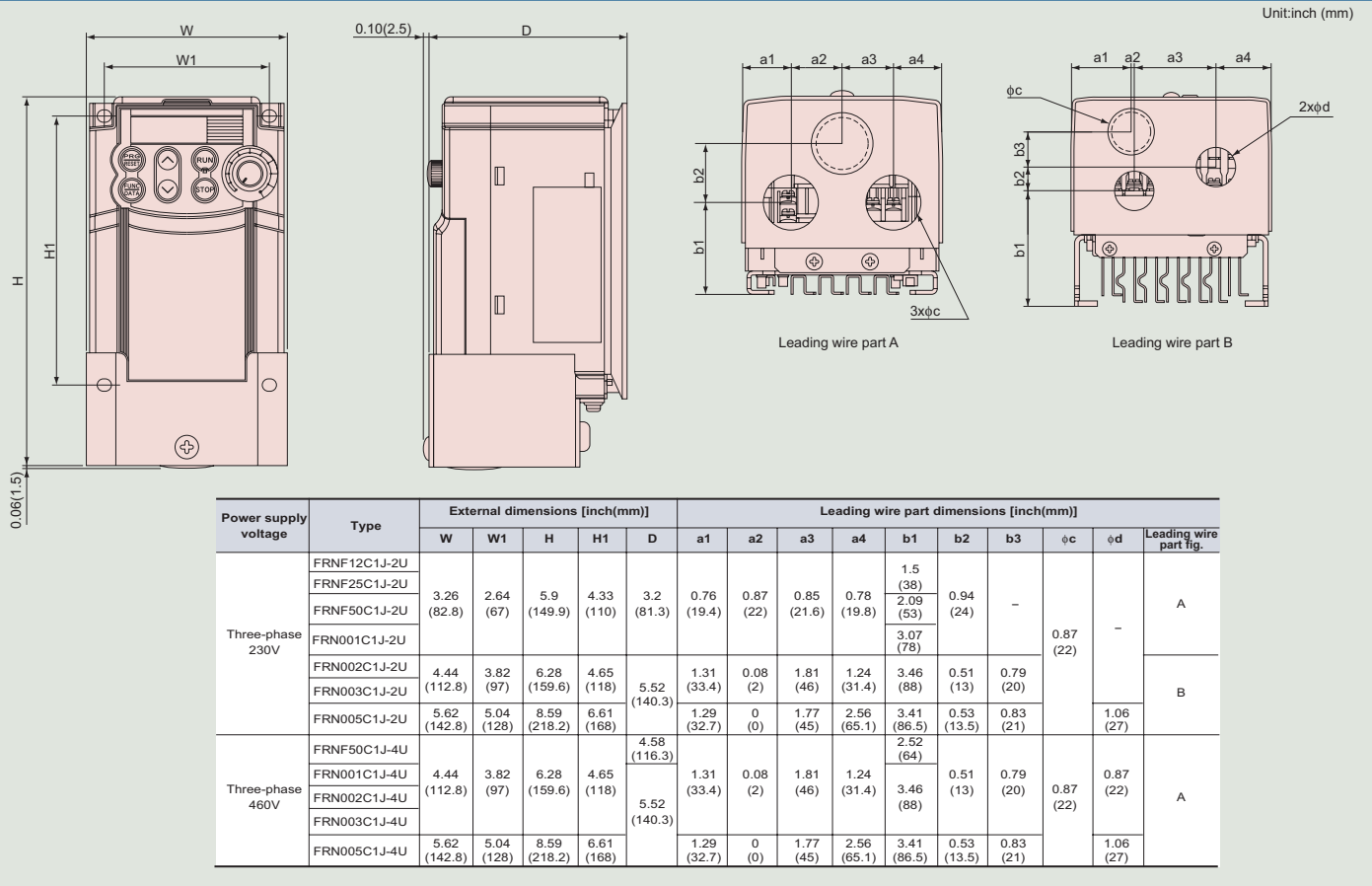

Type1 (NEMA1) type

Fig. 1

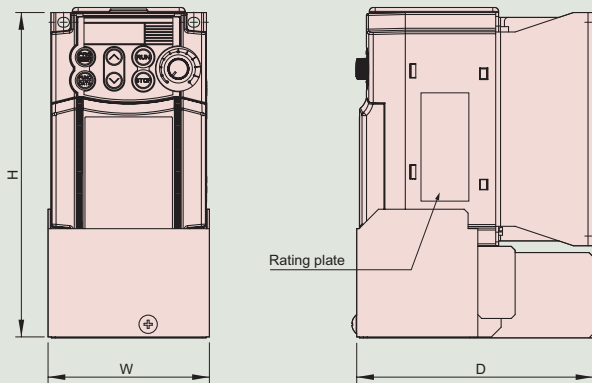

| Type | Dimensions [inch(mm)] | | |
|---------------|-----------------------|-----------|-------------|
| | W | H | D |
| NEMA1-F25C1-2 | | | 3.21(81.5) |
| NEMA1-F50C1-2 | 3.27(83) | 6.69(170) | 3.8(96.5) |
| NEMA1-001C1-2 | | | 4.78(121.5) |
| NEMA1-F50C1-4 | 4.45(113) | 7.09(180) | 4.59(116.5) |
| NEMA1-001C1-4 | | | 5.53(140.5) |
| NEMA1-001C1-7 | 3.27(83) | 6.69(170) | 5.57(141.5) |
| NEMA1-F25C1-6 | 3.27(83) | 6.69(170) | 4.00(101.5) |
| NEMA1-F50C1-6 | | | 4.59(116.5) |
| NEMA1-001C1-6 | 4.45(113) | 7.09(180) | 5.53(140.5) |

Fig. 2

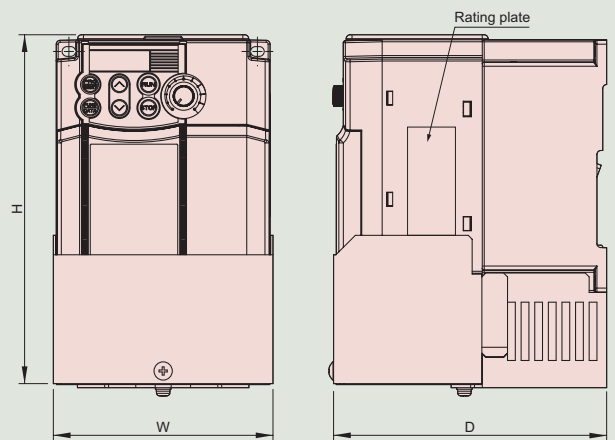

| Type | Dimensions [inch(mm)] | | |
|---------------|-----------------------|-------------|-------------|
| | W | H | D |
| NEMA1-003C1-2 | 4.45(113) | 7.15(181.6) | 5.53(140.5) |
| NEMA1-005C1-2 | 5.63(143) | 9.91(251.6) | 5.53(140.5) |
| NEMA1-002C1-7 | 4.45(113) | 7.15(181.6) | 5.93(150.5) |

Note) • The above dimensions are for the inverter enclosed with the optional NEMA1 kit.

Keypad Operations

Keypad switches and functions

The Compact Inverter **FRENIC-Mini**

LED monitor

When the motor is running or stopped:

The monitor displays the speed monitor (such as output frequency before slip compensation, after slip compensation, set frequency, motor speed, load shaft speed), output voltage, output current, output voltage, and input power.

Alarm mode:

The monitor shows the cause of trip with a fault code.

Program/Reset key

Used to change the mode.

Programming mode:

Used to shift the digit (cursor movement) to set function codes or data.

Alarm mode:

Resets a trip.

Function/Data select key

Used to change the LED monitor and to store the function codes and data.

Up/Down keys

During operation:

Used to increase or decrease the frequency or motor speed.

In data setting:

Used to increase or decrease the function code number or data set value.

Run key

Used to start the operation.

While the motor is stopped:

This key is invalid if the function code **F 02** is set to **1** (operation by external signals).

Stop key

Used to stop the operation.

During operation:

This key is invalid if the function code **F 02** is set to **1** (operation by external signals).

The inverter stops when the function code **H 96** is set to **1** or **3**.

Potentiometer

Used to set the frequency, or make auxiliary frequency setting 1, 2, and issue the PID process commands.



Monitor display and key operation The keypad modes are classified in the following 3 modes.

The Compact Inverter **FRENIC-Mini**

| Operation mode | | Programming mode | | Running mode | | Alarm mode |
|----------------|----------|--|--|---|-------------------------------------|--|
| | | STOP | RUN | STOP | RUN | |
| Monitor | Function | Displays the function code or data code. | | Displays the output frequency, set frequency, loaded motor speed, input power, output current, output voltage, and motor speed. | | Displays the trip content or alarm history. |
| | Display | ON | | Blinking | ON | |
| Keys | Function | PRG/RESET | Switches to stop mode. / Switches to running mode. | Switches to programming mode (STOP). | Switches to programming mode (RUN). | Releases the trip and switches to stop mode. |
| | Function | FUNC/DATA | Digit shift (cursor movement) in function code/data setting | Switches the LED monitor display. | | Displays the operation information. |
| | Function | Up/Down | Changes the display between function code and data code, stores data code, and updates then function code. | Switches the LED monitor display. | | Displays the operation information. |
| | Function | Up/Down | Increases/decreases the function code number and data code. | Increases/decreases the frequency, motor speed, and line speed to be set. | | Displays the alarm history. |
| | Function | RUN | Invalid | Switches to running mode (RUN). | Invalid | Invalid |
| Function | STOP | Invalid | Switches to programming mode (STOP). | Invalid | Switches to running mode (STOP). | Invalid |

This keypad supports a full menu mode which allows you to set or display the following information. Changed function code, operation monitor, I/O check, maintenance information, and trip information For details, refer to the FRENIC-Mini Instruction Manual or User's Manual.

Terminal Functions

The Compact Inverter FRENIC-Mini

| | Symbol | Terminal name | Functions | Remarks | Related function code | | | | | | | | | | | | | | | | | | | | | | | | | | | | | | | | | | | | | | | | | | | | | | | | | | | | | |
|---------------|---------------------------------|---|---|--|--|------------|-----------|----|----|----|----|---|--|--|---------------|--|---|---|---|---|---|---|---|---|-------|---|----|---|----|---|----|---|----|---|----|-------|---|---|----|----|---|---|----|----|---|---|-------|---|---|---|---|---|----|----|----|----|---|------------|
| Main circuit | L1/R, L2/S, L3/T | Power input | Connect a three-phase power supply. | Three-phase 230V, 460V series | | | | | | | | | | | | | | | | | | | | | | | | | | | | | | | | | | | | | | | | | | | | | | | | | | | | | | |
| | L1/L, □, L2/N | | Connect a single-phase power supply. (□ indicates the empty terminal.) | Single-phase 230V, 115V series | | | | | | | | | | | | | | | | | | | | | | | | | | | | | | | | | | | | | | | | | | | | | | | | | | | | | | |
| | U, V, W | Inverter output | Connect a three-phase induction motor. | | | | | | | | | | | | | | | | | | | | | | | | | | | | | | | | | | | | | | | | | | | | | | | | | | | | | | | |
| | P(+), P1 | For DC REACTOR | Connect the DC REACTOR. | | | | | | | | | | | | | | | | | | | | | | | | | | | | | | | | | | | | | | | | | | | | | | | | | | | | | | | |
| | P(+), N(-) | For DC bus connection | Used for DC bus connection system. | | | | | | | | | | | | | | | | | | | | | | | | | | | | | | | | | | | | | | | | | | | | | | | | | | | | | | | |
| | P(+), DB | For EXTERNAL BRAKING RESISTOR | Used for connection of the optional external BRAKING RESISTOR. | Wiring is required for the braking resistor built-in type. | | | | | | | | | | | | | | | | | | | | | | | | | | | | | | | | | | | | | | | | | | | | | | | | | | | | | | |
| ⊕ G | Grounding | Ground terminal for inverter chassis | Two terminals are provided. | | | | | | | | | | | | | | | | | | | | | | | | | | | | | | | | | | | | | | | | | | | | | | | | | | | | | | | |
| Analog input | 13 | Potentiometer power supply | +10V DC power supply for frequency setting potentiometer (1 to 5kΩ) | Allowable maximum output current: 10mA | | | | | | | | | | | | | | | | | | | | | | | | | | | | | | | | | | | | | | | | | | | | | | | | | | | | | | |
| | 12 | Voltage input | 0 to +10V DC / 0 to 100% 0 to +5V DC / 0 to 100% or +1 to +5V DC / 0 to 100% can be selected by function setting. +10 to +0V DC / 0 to 100% (switchable by digital input signal) | Input impedance: 22kΩ Allowable maximum input voltage: 15V DC If input voltage is +10V DC or over, the inverter assumes it to be +10V DC. | F18, C32 to C34 | | | | | | | | | | | | | | | | | | | | | | | | | | | | | | | | | | | | | | | | | | | | | | | | | | | | | |
| | | | (PID control) | Used for reference signal (PID process command) or PID feedback signal. | E61 | | | | | | | | | | | | | | | | | | | | | | | | | | | | | | | | | | | | | | | | | | | | | | | | | | | | | |
| | | | (Frequency aux. setting) | Used as additional auxiliary setting to various main settings of frequency. | E61 | | | | | | | | | | | | | | | | | | | | | | | | | | | | | | | | | | | | | | | | | | | | | | | | | | | | | |
| | C1 | Current input (Inverse operation) | +4 to +20mA DC / 0 to 100% +20 to +4mA DC / 0 to 100% (switchable by digital input signal) | Input impedance: 250Ω Allowable maximum input current: +30mA DC If input voltage is +20mA DC or over, the inverter assumes it to be +20mA DC. | F18, C35 to C37 | | | | | | | | | | | | | | | | | | | | | | | | | | | | | | | | | | | | | | | | | | | | | | | | | | | | | |
| | | | (PID control) | Used for reference signal (PID process command) or PID feedback signal. | E62 | | | | | | | | | | | | | | | | | | | | | | | | | | | | | | | | | | | | | | | | | | | | | | | | | | | | | |
| | | | (For PTC thermistor) | Connects PTC thermistor for motor protection. | Connect external resistor 1kΩ to terminal 13 - C1. H26, H27 | | | | | | | | | | | | | | | | | | | | | | | | | | | | | | | | | | | | | | | | | | | | | | | | | | | | | |
| | | | (Frequency aux. setting) | Used as additional auxiliary setting to various main settings of frequency. | E62 | | | | | | | | | | | | | | | | | | | | | | | | | | | | | | | | | | | | | | | | | | | | | | | | | | | | | |
| | 11 | Common | Common for analog input/output signals (12, 13, C1) | Isolated from terminal CM and Y1E.. | | | | | | | | | | | | | | | | | | | | | | | | | | | | | | | | | | | | | | | | | | | | | | | | | | | | | | |
| | Digital input | X1 | Digital input 1 | The following functions can be set at terminals X1 to X3, FWD, and REV for signal input. | <ON state> • Source current: 2.5 to 5mA (When input voltage is 0V) • Maximum input voltage: 2V <OFF state> • Allowable maximum leakage current: 0.5mA • Maximum terminal voltage: 22 to 27V | E01 to E03 | | | | | | | | | | | | | | | | | | | | | | | | | | | | | | | | | | | | | | | | | | | | | | | | | | | | |
| X2 | | Digital input 2 | (FWD and REV functions are factory-set at FWD and REV terminals, respectively. | | | | | | | | | | | | | | | | | | | | | | | | | | | | | | | | | | | | | | | | | | | | | | | | | | | | | | | |
| X3 | | Digital input 3 | <Common function> Sink/Source changeover function: Sink and source are changeable using the built-in jumper switch. | | | | | | | | | | | | | | | | | | | | | | | | | | | | | | | | | | | | | | | | | | | | | | | | | | | | | | | |
| FWD | | Forward operation command | Contact activation mode changeover function: ON timing can be changed between short-circuit of terminals X1 and CM and open circuit of them. The same setting is possible between CM and any of the terminals among X2, X3, FWD, and REV. | | | | | | | | | | | | | | | | | | | | | | | | | | | | | | | | | | | | | | | | | | | | | | | | | | | | | | | |
| REV | | Reverse operation command | | | | | | | | | | | | | | | | | | | | | | | | | | | | | | | | | | | | | | | | | | | | | | | | | | | | | | | | |
| (FWD) | | Forward operation command | (FWD): ON... The motor runs in the forward direction. (FWD): OFF... The motor decelerates and stops. | When FWD and REV are simultaneously ON, the motor decelerates and stops. This function can be set only for the terminals FWD and REV. | E98, E99 | | | | | | | | | | | | | | | | | | | | | | | | | | | | | | | | | | | | | | | | | | | | | | | | | | | | | |
| (REV) | | Reverse operation command | (REV): ON... The motor runs in the reverse direction. OFF... The motor decelerates and stops. | | | | | | | | | | | | | | | | | | | | | | | | | | | | | | | | | | | | | | | | | | | | | | | | | | | | | | | |
| (SS1) | | Multistep freq. selection | 2 (0, 1) different frequencies are selectable. | <table border="1"> <thead> <tr> <th colspan="2"></th> <th colspan="8">Frequency</th> </tr> <tr> <th>Digital input</th> <th></th> <th>0</th> <th>1</th> <th>2</th> <th>3</th> <th>4</th> <th>5</th> <th>6</th> <th>7</th> </tr> </thead> <tbody> <tr> <td>(SS1)</td> <td>—</td> <td>ON</td> <td>—</td> <td>ON</td> <td>—</td> <td>ON</td> <td>—</td> <td>ON</td> <td>—</td> <td>ON</td> </tr> <tr> <td>(SS2)</td> <td>—</td> <td>—</td> <td>ON</td> <td>ON</td> <td>—</td> <td>—</td> <td>ON</td> <td>ON</td> <td>—</td> <td>—</td> </tr> <tr> <td>(SS4)</td> <td>—</td> <td>—</td> <td>—</td> <td>—</td> <td>—</td> <td>ON</td> <td>ON</td> <td>ON</td> <td>ON</td> <td>—</td> </tr> </tbody> </table> | | | Frequency | | | | | | | | Digital input | | 0 | 1 | 2 | 3 | 4 | 5 | 6 | 7 | (SS1) | — | ON | — | ON | — | ON | — | ON | — | ON | (SS2) | — | — | ON | ON | — | — | ON | ON | — | — | (SS4) | — | — | — | — | — | ON | ON | ON | ON | — | C05 to C11 |
| | | | Frequency | | | | | | | | | | | | | | | | | | | | | | | | | | | | | | | | | | | | | | | | | | | | | | | | | | | | | | | |
| Digital input | | | | | 0 | 1 | 2 | 3 | 4 | 5 | 6 | 7 | | | | | | | | | | | | | | | | | | | | | | | | | | | | | | | | | | | | | | | | | | | | | | |
| (SS1) | | — | ON | — | ON | — | ON | — | ON | — | ON | | | | | | | | | | | | | | | | | | | | | | | | | | | | | | | | | | | | | | | | | | | | | | | |
| (SS2) | | — | — | ON | ON | — | — | ON | ON | — | — | | | | | | | | | | | | | | | | | | | | | | | | | | | | | | | | | | | | | | | | | | | | | | | |
| (SS4) | | — | — | — | — | — | ON | ON | ON | ON | — | | | | | | | | | | | | | | | | | | | | | | | | | | | | | | | | | | | | | | | | | | | | | | | |
| (SS2) | | 4 (0 to 3) different frequencies are selectable. | | | | | | | | | | | | | | | | | | | | | | | | | | | | | | | | | | | | | | | | | | | | | | | | | | | | | | | | |
| (SS4) | | 8 (0 to 7) different frequencies are selectable. Frequency 0 indicates the frequency set by the keypad, built-in potentiometer or analog signal. | | | | | | | | | | | | | | | | | | | | | | | | | | | | | | | | | | | | | | | | | | | | | | | | | | | | | | | | |
| (RT1) | | ACC/DEC time selection | (RT1): ON... ACC/DEC time 2 is effective. (RT1): OFF... ACC/DEC time 1 is effective. | Switchable during ACC/DEC operation | E10, E11 | | | | | | | | | | | | | | | | | | | | | | | | | | | | | | | | | | | | | | | | | | | | | | | | | | | | | |
| (HLD) | | 3-wire operation stop command | Used for 3-wire operation. (HLD): ON... The inverter self-holds FWD or REV signal. (HLD): OFF... The inverter releases self-holding. | | | | | | | | | | | | | | | | | | | | | | | | | | | | | | | | | | | | | | | | | | | | | | | | | | | | | | | |
| (BX) | Coast-to-stop command | (BX): ON... The inverter output is shut off immediately and the motor will coast-to-stop. | No alarm signal will be output. | | | | | | | | | | | | | | | | | | | | | | | | | | | | | | | | | | | | | | | | | | | | | | | | | | | | | | | |
| (RST) | Alarm reset | (RST): ON... Faults are reset. | ON signal should be held for more than 0.1s. | | | | | | | | | | | | | | | | | | | | | | | | | | | | | | | | | | | | | | | | | | | | | | | | | | | | | | | |
| (THR) | Trip command (External fault) | (THR): OFF... The inverter output is shut off and the motor coasts-to-stop. | Alarm signal OH2 will be output. | | | | | | | | | | | | | | | | | | | | | | | | | | | | | | | | | | | | | | | | | | | | | | | | | | | | | | | |
| (JOG) | Jogging operation | (JOG): ON... JOG frequency is effective. (FWD): ON or (REV): ON... The inverter operates with JOG frequency. | | C20, H54 | | | | | | | | | | | | | | | | | | | | | | | | | | | | | | | | | | | | | | | | | | | | | | | | | | | | | | |
| (Hz2/Hz1) | Freq. set 2/ Freq. set 1 | (Hz2): ON or (Hz1): ON... Freq. set 2 is effective. | | F01, C30 | | | | | | | | | | | | | | | | | | | | | | | | | | | | | | | | | | | | | | | | | | | | | | | | | | | | | | |
| (WE-KP) | Write enable for KEYPAD | (WE-KP): ON... The function code data can be changed from the keypad. | Data can be changed when this function is not allocated. | | | | | | | | | | | | | | | | | | | | | | | | | | | | | | | | | | | | | | | | | | | | | | | | | | | | | | | |
| (Hz/PID) | PID control cancel | (Hz/PID): ON... The PID control is canceled, and frequency set by multistep frequency, keypad or analog input. | | J01 to J06 F01, C30 | | | | | | | | | | | | | | | | | | | | | | | | | | | | | | | | | | | | | | | | | | | | | | | | | | | | | | |
| (IVS) | Inverse mode changeover | (IVS): ON... Operation mode (normal operation/ inverse operation) can be changed. | | | | | | | | | | | | | | | | | | | | | | | | | | | | | | | | | | | | | | | | | | | | | | | | | | | | | | | | |
| (LE) | Link enable (RS-485, Bus) | (LE): ON... The link operation is effective. (RS-485 or Bus (Option)) | | H30, y99 | | | | | | | | | | | | | | | | | | | | | | | | | | | | | | | | | | | | | | | | | | | | | | | | | | | | | | |
| (PID-RST) | PID integral/differential reset | (PID-RST): ON... PID integration and differentiation are reset. | | | | | | | | | | | | | | | | | | | | | | | | | | | | | | | | | | | | | | | | | | | | | | | | | | | | | | | | |
| (PID-HLD) | PID integral hold | (PID-HLD): ON... PID integration is temporarily stopped. | | | | | | | | | | | | | | | | | | | | | | | | | | | | | | | | | | | | | | | | | | | | | | | | | | | | | | | | |
| PLC | PLC terminal | Connect to PLC output signal power supply. Common for 24V power (terminal P24). | +24V 50mA max. | | | | | | | | | | | | | | | | | | | | | | | | | | | | | | | | | | | | | | | | | | | | | | | | | | | | | | | |
| CM | Common | Common for digital input signal. | Isolated from terminal 11 and Y1E. | | | | | | | | | | | | | | | | | | | | | | | | | | | | | | | | | | | | | | | | | | | | | | | | | | | | | | | |

Terminal Functions

Terminal Functions

The Compact Inverter **FRENIC-Mini**

| | Symbol | Terminal name | Functions | Remarks | Related function code |
|-------------------|-----------------------------|--|--|--|---------------------------|
| Analog output | FMA | Analog monitor | <ul style="list-style-type: none"> Output frequency (Before slip compensation) Output frequency (After slip compensation) Input power PID feedback value DC link circuit voltage Analog output test (+) | Voltage output: 0 to 10V Max. current: 2mA Up to two analog voltmeters can be connected. | F30,F31 |
| | 11 | Common | Common for analog input/output signals (FMA). | Insulated from the terminals CM and Y1E. | |
| Transistor output | Y1 | Transistor output | The following functions can be set at terminal Y1, signal output. • Contact activation mode changeover function: ON timing can be changed by shorting terminals Y1 and Y1E and opening them. | 27V max., 50mA max. OFF state maximum leakage current: 0.1mA ON state maximum output voltage: 2V at 50mA | E20 |
| | (RUN) | Inverter running (speed exists) | Comes ON when the output frequency is higher than starting frequency. | | |
| | (RUN2) | Inverter output on | Comes on when the output frequency is higher than the starting frequency or DC injection brake is applied. | | |
| | (FAR) | Speed/freq. arrival | Comes ON when the motor speed reaches the set frequency. (Condition: Operation command is ON.) | FAR hysteresis width (fixed): 2.5Hz | |
| | (FDT) | Speed/freq. detection | Comes ON when the output frequency is above the detectable level and goes OFF when below the detectable level. | Hysteresis width (fixed): 1.0Hz | E31 |
| | (LV) | Undervoltage detection | Comes ON when the inverter stops because of undervoltage while the operation command is ON. | | |
| | (IOL) | Inverter output limit (limit on current) | Comes ON when the inverter is limiting the current. | | F43,F44 |
| | (IPF) | Auto-restarting | Comes ON during auto restart operation (after momentary power failure and until completion of restart) | | F14 |
| | (OL) | Overload early warning (motor) | Comes ON when the electronic thermal relay value is higher than the preset alarm level. | | F10 to F12 |
| | (TRY) | Auto-resetting mode | Comes ON during auto reset mode. | | H04,H05 |
| | (LIFE) | Lifetime alarm | Outputs alarm signal according to the preset lifetime level. | | H42,H43,H98 |
| | (OLP) | Overload preventive control | Comes ON during inverter control for avoiding overload. | | H70 |
| | (ID) | Current detection | Comes ON when a current larger than the set value has been detected for the timer-set time. | | E34,E35 |
| (IDL) | Small current detection | Comes ON when a current smaller than the set value has been detected for the timer-set time. | | E34,E35 | |
| (ALM) | Alarm relay (for any fault) | Alarm signal is output as the transistor output signal. | | | |
| | Y1E | Transistor output common | Emitter output of transistor output signal (Y1) | Isolated from terminal 11 and CM. | |
| Relay output | 30A,30B,30C | Alarm relay output (for any fault) | <ul style="list-style-type: none"> Outputs a contact signal (SPDT) when a protective function is activated to stop inverter. This terminal can be used as the multi-purpose relay output signal. (Possible to select a terminal similar to Y1 for transistor output signal and use it for signal output.) Contact activation mode can be changed between the following two cases: "terminals 30A and 30C are shorted by ON signal output" or "terminals 30B and 30C" are shorted by ON signal output" | Contact rating : 250V AC, 0.3A, cosφ=0.3 | E27 |
| LINK | RS-485 port connector *1 | RS-485 I/O terminal | <ul style="list-style-type: none"> Used to connect the inverter with the remote keypad to supply the power to the keypad. Used to connect the inverter with PC or PLC using RS-485 port. | RJ45 connector is used. For the transmission specifications, refer to page 25. | H30 y01 to y10, y99 |

*1) This terminal is valid when the standard inverter is equipped with RS-485 communication card (option).

Terminal Arrangement

The Compact Inverter **FRENIC-Mini**

Main circuit terminals

| Power source | Nominal applied motor (HP) | Inverter type | Reference |
|-------------------|----------------------------|----------------|-----------|
| Three-phase 230V | 1/8 | FRNF12C1□-2U** | Fig. A |
| | 1/4 | FRNF25C1□-2U** | |
| | 1/2 | FRNF50C1□-2U** | |
| | 1 | FRN001C1□-2U** | |
| | 2 | FRN002C1□-2U** | |
| Three-phase 460V | 3 | FRN003C1□-2U** | Fig. B |
| | 5 | FRN005C1□-2U** | |
| | 1/2 | FRNF50C1□-4U** | |
| | 1 | FRN001C1□-4U** | |
| | 2 | FRN002C1□-4U** | |
| Single-phase 230V | 3 | FRN003C1□-4U** | Fig. C |
| | 5 | FRN005C1□-4U** | |
| | 1/8 | FRNF12C1□-7U | |
| | 1/4 | FRNF25C1□-7U | |
| | 1/2 | FRNF50C1□-7U | |
| Single-phase 115V | 1 | FRN001C1□-7U | Fig. D |
| | 2 | FRN002C1□-7U | |
| | 3 | FRN003C1□-7U | |
| | 1/8 | FRNF12C1□-6U | |
| | 1/4 | FRNF25C1□-6U | |
| 1/2 | FRNF50C1□-6U | Fig. C | |
| 1 | FRN001C1□-6U | | |

Fig. A

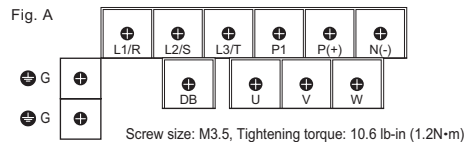

Fig. C

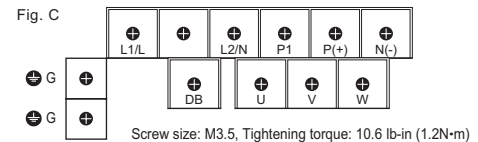

Fig. B

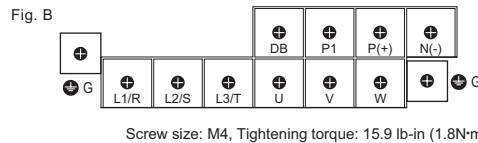
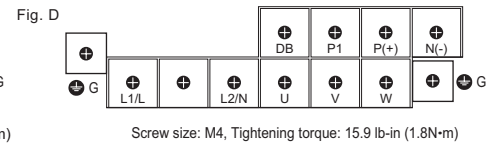
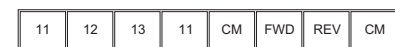

Fig. D



Note) For the inverter type FRNF12C1□2U**, the symbol □ is replaced with either of the following alphabets and ** is replaced with any of the following numeral codes:
 □ S (Standard type), E (EMC filters built-in type), **: 21 (Braking resistor built-in type), None (Standard type)
 The inverter applicable to RS-485 communication is limited to the standard ones in three-phase 230V and three-phase 460V series.
 The braking resistor built-in type is limited to the inverters for 2HP or larger.

Control circuit terminals (common to all the inverter models)



Screw size: M2, Tightening torque: 1.8 lb-in (0.2N-m)



Screw size: M2.5, Tightening torque: 3.5 lb-in (0.4N-m)

Basic wiring diagram

The Compact Inverter **FRENIC-Mini**

The following diagram is for reference only. For detailed wiring diagrams, refer to the Instruction Manual.

Keypad operation

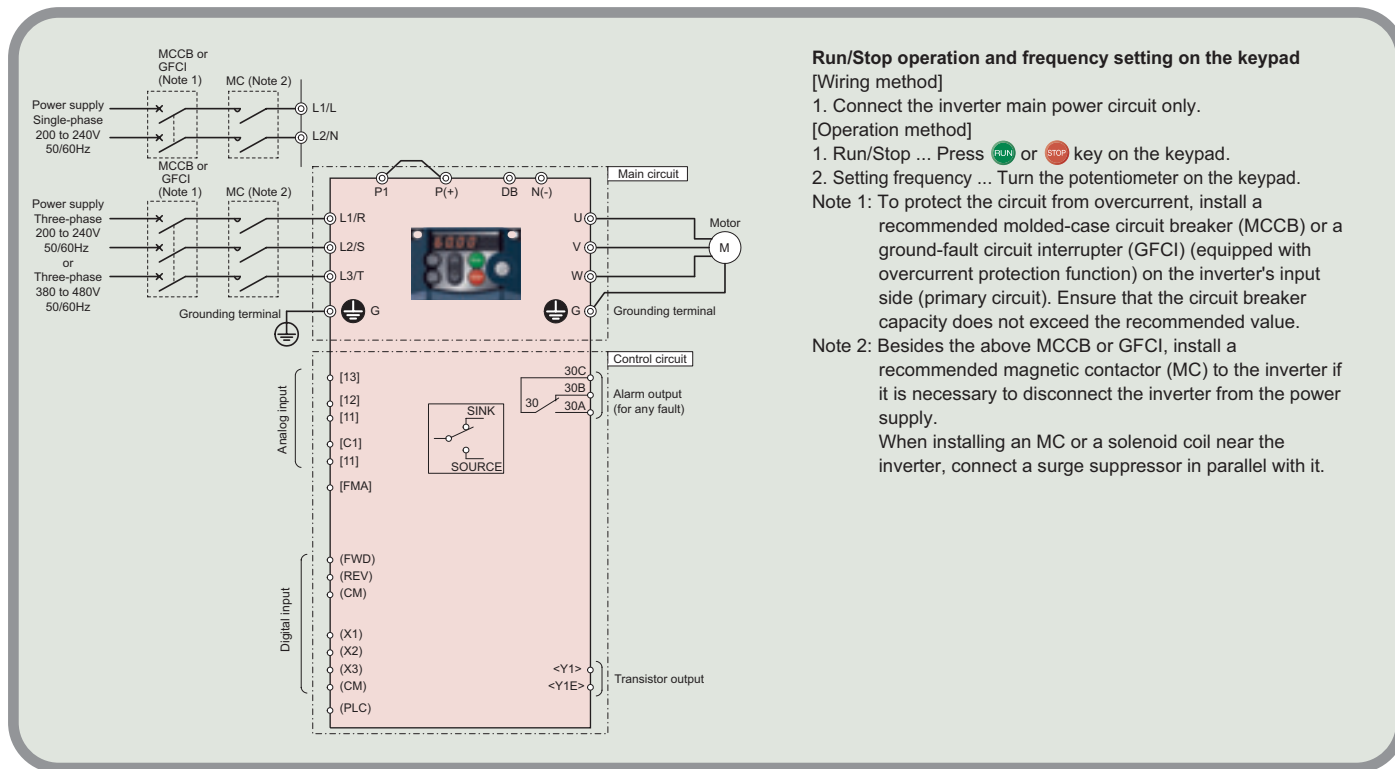

Run/Stop operation and frequency setting on the keypad

[Wiring method]

1. Connect the inverter main power circuit only.

[Operation method]

1. Run/Stop ... Press **RUN** or **STOP** key on the keypad.

2. Setting frequency ... Turn the potentiometer on the keypad.

Note 1: To protect the circuit from overcurrent, install a recommended molded-case circuit breaker (MCCB) or a ground-fault circuit interrupter (GFCI) (equipped with overcurrent protection function) on the inverter's input side (primary circuit). Ensure that the circuit breaker capacity does not exceed the recommended value.

Note 2: Besides the above MCCB or GFCI, install a recommended magnetic contactor (MC) to the inverter if it is necessary to disconnect the inverter from the power supply.

When installing an MC or a solenoid coil near the inverter, connect a surge suppressor in parallel with it.

Operation by external signal inputs

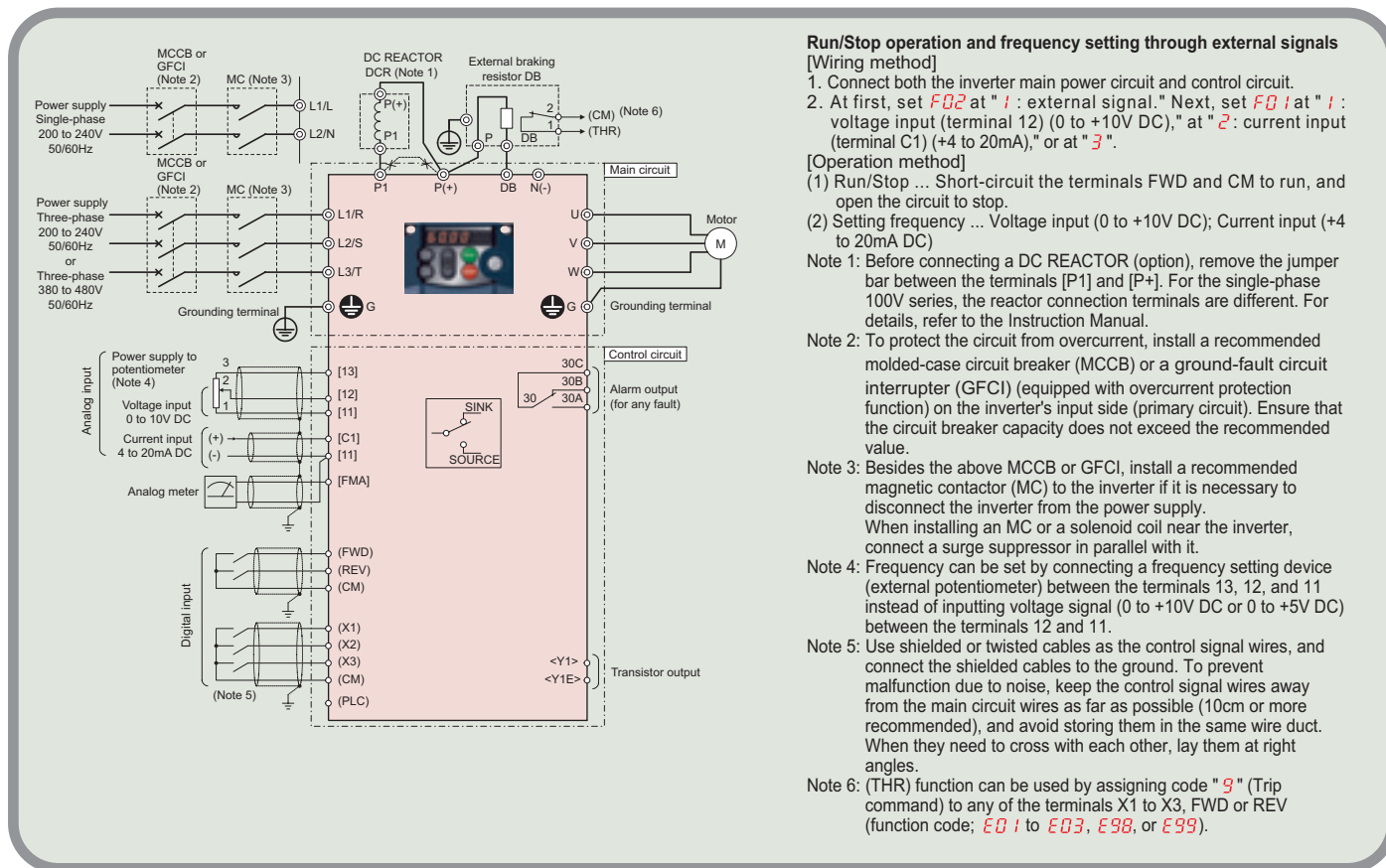

Run/Stop operation and frequency setting through external signals

[Wiring method]

1. Connect both the inverter main power circuit and control circuit.

2. At first, set **FB2** at "1": external signal." Next, set **FB1** at "1": voltage input (terminal 12) (0 to +10V DC)," at "2": current input (terminal C1) (+4 to 20mA)," or at "3".

[Operation method]

(1) Run/Stop ... Short-circuit the terminals FWD and CM to run, and open the circuit to stop.

(2) Setting frequency ... Voltage input (0 to +10V DC); Current input (+4 to 20mA DC)

Note 1: Before connecting a DC REACTOR (option), remove the jumper bar between the terminals [P1] and [P+]. For the single-phase 100V series, the reactor connection terminals are different. For details, refer to the Instruction Manual.

Note 2: To protect the circuit from overcurrent, install a recommended molded-case circuit breaker (MCCB) or a ground-fault circuit interrupter (GFCI) (equipped with overcurrent protection function) on the inverter's input side (primary circuit). Ensure that the circuit breaker capacity does not exceed the recommended value.

Note 3: Besides the above MCCB or GFCI, install a recommended magnetic contactor (MC) to the inverter if it is necessary to disconnect the inverter from the power supply. When installing an MC or a solenoid coil near the inverter, connect a surge suppressor in parallel with it.

Note 4: Frequency can be set by connecting a frequency setting device (external potentiometer) between the terminals 13, 12, and 11 instead of inputting voltage signal (0 to +10V DC or 0 to +5V DC) between the terminals 12 and 11.

Note 5: Use shielded or twisted cables as the control signal wires, and connect the shielded cables to the ground. To prevent malfunction due to noise, keep the control signal wires away from the main circuit wires as far as possible (10cm or more recommended), and avoid storing them in the same wire duct. When they need to cross with each other, lay them at right angles.

Note 6: (THR) function can be used by assigning code "9" (Trip command) to any of the terminals X1 to X3, FWD or REV (function code; E01 to E03, E98, or E99).

Function Settings

Function Settings

The Compact Inverter **FRENIC-Mini**

Fundamental Functions: F codes

| Func. code | Name | Data setting range | Min. | Unit | Factory setting |
|------------|---|--|-------|------|--|
| F00 | Data Protection | 0 : Disable data protection 1 : Enable data protection | — | — | 0 |
| F01 | Frequency Command 1 | 0 : Keypad operation (▲ or ▼ key) 1 : Analog voltage input (terminal 12) (0 to +10V DC) 2 : Analog current input (terminal C1) (+4 to +20mA DC) 3 : Analog voltage input (terminals 12) and analog current input (terminal C1) 4 : Potentiometer on the keypad | — | — | 4 |
| F02 | Running/Stopping and Rotational Direction | 0 : Keypad operation (FWD/REV change by external signal) 1 : External signal (Digital input) 2 : Keypad operation (FWD) 3 : Keypad operation (REV) | — | — | 2 |
| F03 | Maximum Frequency | 25.0 to 400.0Hz | 0.1 | Hz | 60.0 |
| F04 | Base Frequency | 25.0 to 400.0Hz | 0.1 | Hz | 60.0 |
| F05 | Rated Voltage (at base frequency) | 0V : Voltage in proportion to power supply voltage 80 to 240V : AVR active (115, 230V series) 160 to 500V : AVR active (460V series) | 1 | V | 230 460 |
| F07 | Acceleration Time 1 | 0.00 to 3600s : *0.00 means acceleration time ignored (External soft start/stop) | 0.01 | s | 6.00 |
| F08 | Deceleration Time 1 | 0.00 to 3600s : *0.00 means deceleration time ignored (External soft start/stop) | 0.01 | s | 6.00 |
| F09 | Torque Boost | 0.0 to 20.0% (percentage against F05: Rated voltage) *Setting becomes valid when F37 is set at 0, 1, 3 or 4. | 0.1 | % | Fuji's standard torque boost |
| F10 | Electronic Thermal Overload for motor protection (Select the motor property) | 1 : For motor with self-cooled fan, standard motor 2 : For motor with forced-cooled fan | — | — | 1 |
| F11 | (Overload detection level) | 0.00%(Inactive), Approx. 1 to 135% of inverter rated current | 0.01 | A | Rated current of Fuji's standard motor |
| F12 | (Thermal time constant) | 0.5 to 75.0min | 0.1 | min | 5.0 |
| F14 | Restart Mode after Instantaneous Power Failure | 0 : Inactive (Trips immediately without restart when power fails.) 1 : Inactive (Trips without restart when power recovers.) 4 : Active (Restarts at frequency output at power failure, for general load) 5 : Active (Restarts at starting frequency, for low-inertia load) | — | — | 0 |
| F15 | Frequency Limiter (Peak) | 0.0 to 400.0Hz | 0.1 | Hz | 70.0 |
| F16 | (Bottom) | 0.0 to 400.0Hz | 0.1 | Hz | 0.0 |
| F18 | Bias (for Frequency Command 1) | -100.00 to 100.00% | 0.01 | % | 0.00 |
| F20 | DC Braking (Starting frequency) | 0.0 to 60.0Hz | 0.1 | Hz | 0.0 |
| F21 | (Braking level) | 0 to 100% | 1 | % | 0 |
| F22 | (Braking time) | 0.00 (Inactive), 0.01 to 30.00s | 0.01 | s | 0.00 |
| F23 | Starting Frequency | 0.1 to 60.0Hz | 0.1 | Hz | 1.0 |
| F25 | Stop Frequency | 0.1 to 60.0Hz | 0.1 | Hz | 0.2 |
| F26 | Motor Sound (Carrier frequency) | 0.75 to 15kHz | 1 | kHz | 2 |
| F27 | (Sound tone) | 0 : Level 0 1 : Level 1 2 : Level 2 3 : Level 3 | — | — | 0 |
| F30 | Terminal [FMA] (Gain to output voltage) | 0 to 200% | 1 | % | 100 |
| F31 | Analog Output Signal Selection for [FMA] (Monitor object) | Selects from the following items by code. 0 : Output frequency (before slip compensation) 1 : Output frequency (after slip compensation) 2 : Output current 3 : Output voltage 6 : Input power 7 : PID feedback value 9 : DC link circuit voltage 14 : Analog output test (+) | — | — | 0 |
| F37 | Load Selection/Auto Torque Boost/Auto Energy Saving Operation | 0 : Variable torque load 1 : Constant torque load 2 : Auto-torque boost 3 : Auto-energy saving operation (Variable torque load during acceleration and deceleration) 4 : Auto-energy saving operation (Constant torque load during acceleration and deceleration) 5 : Auto-energy saving operation (Auto-torque boost during acceleration and deceleration) | — | — | 1 |
| F43 | Current Limiter (Operation condition) | 0 : Inactive 1 : At constant speed (Inactive during acceleration/deceleration) 2 : During acceleration and at constant speed (Inactive during deceleration) | — | — | 2 |
| F44 | (Limiting level) | 20 to 200% (Inverter rated current standard) | 1 | % | 180 |
| F50 | Electronic Thermal Overload Relay (for braking resistor) (Discharging capability) | 0 (Braking resistor built-in type) 1 to 900kW, 999(cancel) | 1 | kW | 999 |
| F51 | (Allowable average loss) | 0.000 (Braking resistor built-in type) 0.001 to 50.000kW | 0.001 | kW | 0.000 |

Function Settings

The Compact Inverter **FRENIC-Mini**

Extension Terminal Functions: E codes

| Func. code | Name | Data setting range | Min. | Unit | Factory setting |
|------------|---|---|-------|------|---|
| E01 | Terminal Command Assignment to: [X1] [X2] [X3] | Selects from the following items by code. | — | — | 0 |
| E02 | | | — | — | 7 |
| E03 | | | — | — | 8 |
| | | 0 : (1000) Multistep freq. selection (0 to 1 step) [SS1] 1 : (1001) Multistep freq. selection (0 to 3 step) [SS2] 2 : (1002) Multistep freq. selection (0 to 7 step) [SS4] 4 : (1004) ACC/DEC time selection (2 steps) [RT1] 6 : (1006) 3-wire operation stop command [HLD] 7 : (1007) Coast-to-stop command [BX] 8 : (1008) Alarm reset [RST] 9 : (1009) Trip command (External fault) [THR] 10 : (1010) Jogging operation [JOG] 11 : (1011) Freq. set 2 / Freq. set 1 [Hz2/Hz1] 19 : (1019) Write enable for keypad (Data changeable) [WE-KP] 20 : (1020) PID control cancel [Hz/PID] 21 : (1021) Normal/Inverse mode changeover [IVS] 24 : (1024) Link enable (RS-485 (standard), BUS (option)) [LE] 33 : (1033) PID integration/differentiation reset [PID-RST] 34 : (1034) PID integration hold [PID-HLD] *The number in () indicates logical inverse. (OFF when short-circuited) | | | |
| E10 | Acceleration Time 2 | 0.00 to 3600s | 0.01 | s | 6.00 |
| E11 | Deceleration Time 2 | 0.00 to 3600s | 0.01 | s | 6.00 |
| E20 | Status Signal Assignment to: [Y1] [30A, B, C] (Mechanical relay contacts) | Selects from the following items by code. | — | — | 0 |
| E27 | | 0 : (1000) Inverter running [RUN] 1 : (1001) Frequency equivalence signal [FAR] 2 : (1002) Frequency level detection [FDT] 3 : (1003) Undervoltage detection signal [LV] 5 : (1005) Torque limiting (Current limiting) [IOL] 6 : (1006) Auto-restarting [IPF] 7 : (1007) Motor overload early warning [OL] 26 : (1026) Retry in operation [TRY] 30 : (1030) Lifetime alarm [LIFE] 35 : (1035) Inverter running [RUN2] 36 : (1036) Overload preventive control [OLP] 37 : (1037) Current detection [ID] 41 : (1041) Low level current detection [IDL] 99 : (1099) Alarm relay output (for any fault) [ALM] *The number in () indicates logical inverse. (OFF when short-circuited) | — | — | 99 |
| E31 | Frequency Detection (FDT) (Detection level) | 0.0 to 400.0Hz | 0.1 | Hz | 60.0 |
| E34 | Overload Early Warning/Current Detection/ Low Current Detection (Level) | 0.00(Inactive), 1 to 200% of inverter rated current | 0.01 | A | Rated current of Fuji's standard motor |
| E35 | Current Detection/Low Current Detection (Timer) | 0.01 to 600.00s | 0.01 | s | 10.00 |
| E39 | Coefficient for Constant Feeding Rate Time | 0.000 to 9.999 | 0.001 | — | 0.000 |
| E40 | PID Display Coefficient A | -999 to 0.00 to 999 | 0.01 | — | 100 |
| E41 | PID Display Coefficient B | -999 to 0.00 to 999 | 0.01 | — | 0.00 |
| E43 | Monitor Item Selection | 0 : Speed monitor (select by E48) 9 : Input power 3 : Output current 10 : PID final command value 4 : Output voltage 12 : PID feedback value 13 : Timer value (timer operation) | — | — | 0 |
| E45 | See Note 2. | | | | |
| E46 | | | | | |
| E47 | | | | | |
| E48 | LED Monitor (Speed monitor item) | 0 : Output frequency (before slip compensation) 1 : Output frequency (after slip compensation) 2 : Setting frequency 4 : Load shaft speed 5 : Line speed 6 : Constant rate of feeding time | — | — | 0 |
| E50 | Coefficient for Speed Indication | 0.01 to 200.00 | 0.01 | — | 30.00 |
| E52 | Keypad (Menu display mode) | 0 : Function code data setting menu only 1 : Data verification menu only 2 : All menu | — | — | 0 |

Note 1: The above setting ranges may be limited by the signs or the number of digits.

Note 2: The inverter does not use the codes **E45** to **E47** though they are displayed.

<Changing, reflecting or storing data during operation>

: Disable
 : Change with keys and then save or reflect with key.
 : Change or reflect with keys and then save with key.

Function Settings

Function Settings

The Compact Inverter *FRENIC-Mini*

Extension Terminal Functions: E codes

| Func. code | Name | Data setting range | Min. | Unit | Factory setting |
|--|--|--|------|------|-----------------|
| E60 | Built-in Potentiometer (Function selection) | Selects from the following functions by code. 0 : No function selection 1 : Aux. freq. setting 1 2 : Aux. freq. setting 2 3 : PID process command 1 | — | — | 0 |
| E61 | Analog Input Signal Definition for: [12] [C1] | Selects from the following functions by code. 0 : No function selection 1 : Aux. freq. setting 1 2 : Aux. freq. setting 2 3 : PID process command 1 5 : PID feedback value | — | — | 0 |
| E62 | | | — | — | 0 |
| E98 | Terminal Command Assignment to: [FWD] [REV] | Selects from the following items by code. 0 : (1000) Multistep freq. selection (0 to 1 step) [SS1] 1 : (1001) Multistep freq. selection (0 to 3 step) [SS2] 2 : (1002) Multistep freq. selection (0 to 7 step) [SS4] 4 : (1004) ACC/DEC time selection (2 steps) [RT1] 6 : (1006) 3-wire operation stop command [HLD] 7 : (1007) Coast-to-stop command [BX] 8 : (1008) Alarm reset [RST] 9 : (1009) Trip command (External fault) [THR] 10 : (1010) Jogging operation [JOG] 11 : (1011) Freq. set 2 / Freq. set 1 [Hz2/Hz1] 19 : (1019) Write enable for keypad (Data changeable) [WE-KP] 20 : (1020) PID control cancel [Hz/PID] 21 : (1021) Normal/Inverse mode changeover [IVS] 24 : (1024) Link enable (RS-485 (standard), BUS (option)) [LE] 33 : (1033) PID integration/differentiation reset [PID-RST] 34 : (1034) PID integration hold [PID-HLD] 98 : Forward operation command [FWD] 99 : Reverse operation command [REV] | — | — | 98 |
| E99 | | | — | — | 99 |
| *The number in () indicates logical inverse. (OFF when short-circuited) | | | | | |

Control Functions of Frequency: C codes

| Func. code | Name | Data setting range | Min. | Unit | Factory setting |
|------------|---|--|------|------|-----------------|
| C01 | Jump Frequency 1 2 3 | 0.0 to 400.0Hz | 0.1 | Hz | 0.0 |
| C02 | | | | | 0.0 |
| C03 | | | | | 0.0 |
| C04 | Jump Frequency Band | 0.0 to 30.0Hz | 0.1 | Hz | 3.0 |
| C05 | Multi-step Frequency Settings 1 2 3 4 5 6 7 | 0.00 to 400.00Hz | 0.01 | Hz | 0.00 |
| C06 | | | | | 0.00 |
| C07 | | | | | 0.00 |
| C08 | | | | | 0.00 |
| C09 | | | | | 0.00 |
| C10 | | | | | 0.00 |
| C11 | | | | | 0.00 |
| C20 | Jogging Frequency | 0.00 to 400.00Hz | 0.01 | Hz | 0.00 |
| C21 | Timer Operation | 0 : Inactive 1 : Active | — | — | 0 |
| C30 | Frequency Command 2 | 0 : Keypad operation (◀ or ▶ key) 1 : Analog voltage input (terminal 12) (0 to +10V DC) 2 : Analog current input (terminal C1) (+4 to +20mA DC) 3 : Analog voltage input (terminals 12) and analog current input (terminal C1) 4 : Potentiometer on the keypad | — | — | 2 |
| C32 | Analog Input Adjustment (Gain) | 0.00 to 200.00% | 0.01 | % | 100.0 |
| C33 | (Gain for terminal input [12]) (Filter) | 0.00 to 5.00s | 0.01 | s | 0.05 |
| C34 | (Gain reference point) | 0.00 to 100.00% | 0.01 | % | 100.0 |
| C37 | Analog Input Adjustment (Gain) | 0.00 to 200.00% | 0.01 | % | 100.0 |
| C38 | (Gain for terminal input [C1]) (Filter) | 0.00 to 5.00s | 0.01 | s | 0.05 |
| C39 | (Gain reference point) | 0.00 to 100.00% | 0.01 | % | 100.0 |
| C50 | Bias(Frequency command 1) (Bias reference point) | 0.00 to 100.00% | 0.01 | % | 0.00 |
| C51 | Bias (PID command 1) (Bias value) | -100.00 to 100.00% | 0.01 | % | 0.00 |
| C52 | (Bias reference point) | 0.00 to 100.00% | 0.01 | % | 0.00 |

Motor Parameters: P codes

| Func. code | Name | Data setting range | Min. | Unit | Factory setting |
|------------|-----------------------------------|--|------|------|--|
| P02 | Motor Parameters (Rated capacity) | 0.01 to 10.00 HP (when P99 = 1) | 0.01 | HP | Nominal applied motor capacity |
| P03 | | 0.01 to 10.00 kW (when P99 = 0, 3, or 4) | 0.01 | kW | |
| P03 | (Rated current) | 0.00 to 99.99A | 0.01 | A | Rated current of Fuji's standard motor |
| P09 | (Slip compensation gain) | 0.0 to 200.0% | 0.1 | % | 0.0 |
| P99 | Motor Selection | 0 : Standard motor (R123, R90) 1 : U.S.-made motor 3 : Standard motor (R88, R90) 4 : Others | — | — | 1 |

Function Settings

High Performance Functions: H Codes

| Func. code | Name | Data setting range | Min. | Unit | Factory setting | | | | | | | | | | | | | | | | | | | | | | | | | | | | | | | | | | | | | | | | |
|--|---|---|------|-------|-----------------|-----|-----|-----|----------------------------|---|-----|----|--|----|----------------------|----|-----|-----|-----|----|-----|----|--------------------------------|--|-----|-----|----|----|-----|-----|----|----|------------------------------|--|-----|-----|-----|-----|----|----|----|----|---|---|---|
| H03 | Data Initializing (Data reset) | 0 : Manual set value 1 : Return to factory set value 2 : Motor parameter initializing (Motor 1) | — | — | 0 | | | | | | | | | | | | | | | | | | | | | | | | | | | | | | | | | | | | | | | | |
| H04 | Retry (No. of retries) | 0 : Inactive, 1 to 10 times | 1 | Times | 0 | | | | | | | | | | | | | | | | | | | | | | | | | | | | | | | | | | | | | | | | |
| H05 | (Latency time) | 0.5 to 20.0s | 0.1 | s | 5.0 | | | | | | | | | | | | | | | | | | | | | | | | | | | | | | | | | | | | | | | | |
| H06 | Cooling Fan ON/OFF | 0 : Inactive 1 : Active (2 HP or more) | — | — | 0 | | | | | | | | | | | | | | | | | | | | | | | | | | | | | | | | | | | | | | | | |
| H07 | Gradual Acceleration/ Deceleration | 0 : Inactive (linear) 1 : S-curve (weak) 2 : S-curve (strong) 3 : Non-linear | — | — | 0 | | | | | | | | | | | | | | | | | | | | | | | | | | | | | | | | | | | | | | | | |
| H12 | Instantaneous Overcurrent Limiting | 0 : Inactive 1 : Active | — | — | 1 | | | | | | | | | | | | | | | | | | | | | | | | | | | | | | | | | | | | | | | | |
| H26 | PTC Thermistor Input | 0 : Inactive 1 : Active | — | — | 0 | | | | | | | | | | | | | | | | | | | | | | | | | | | | | | | | | | | | | | | | |
| H27 | (Level) | 0.00 to 5.00V | 0.01 | V | 1.60 | | | | | | | | | | | | | | | | | | | | | | | | | | | | | | | | | | | | | | | | |
| H30 | Serial Link (Function selection) | (Monitor) (Hz setting) (OPR command) 0 : <input type="radio"/> X X <input type="radio"/> ○ : Enable by inverter and RS-485 1 : <input type="radio"/> RS-485 X <input type="radio"/> RS-485 : Enable by RS-485 2 : <input type="radio"/> X RS-485 <input type="radio"/> RS-485 3 : <input type="radio"/> RS-485 RS-485 <input type="radio"/> X : Enable by inverter | — | — | 0 | | | | | | | | | | | | | | | | | | | | | | | | | | | | | | | | | | | | | | | | |
| H42 | Capacity of DC bus capacitor | Adjustment is needed when capacitor is replaced. | — | — | — | | | | | | | | | | | | | | | | | | | | | | | | | | | | | | | | | | | | | | | | |
| H43 | Accumulated Run Time of Cooling Fan | Adjustment is needed when cooling fan is replaced. | — | h | — | | | | | | | | | | | | | | | | | | | | | | | | | | | | | | | | | | | | | | | | |
| H50 | Non-linear V/f Pattern (Frequency) | 0.0: cancel 0.1 to 400.0Hz | 0.1 | Hz | 0.0 | | | | | | | | | | | | | | | | | | | | | | | | | | | | | | | | | | | | | | | | |
| H51 | (Voltage) | 0 to 240V : AVR active (230V class) 0 to 500V : AVR active (460V class) | 1 | V | 230 460 | | | | | | | | | | | | | | | | | | | | | | | | | | | | | | | | | | | | | | | | |
| H54 | ACC/DEC Time (Jogging operation) | 0.00 to 3600s | 0.01 | s | 6.00 | | | | | | | | | | | | | | | | | | | | | | | | | | | | | | | | | | | | | | | | |
| H54 | Bottom Limiter (Min. freq. when limiter is activated) | 0.0 (Depends on F16 : Freq. limiter (Low)) 0.1 to 60.0Hz | 0.1 | Hz | 2.0 | | | | | | | | | | | | | | | | | | | | | | | | | | | | | | | | | | | | | | | | |
| H59 | Automatic Deceleration | 0 : Inactive 1 : Active | — | — | 0 | | | | | | | | | | | | | | | | | | | | | | | | | | | | | | | | | | | | | | | | |
| H70 | Overload Prevention Control (Frequency drop rate) | 0.00 (equivalent to DEC time) 0.01 to 100.00Hz/s, 999(cancel) | 0.01 | Hz/s | 999 | | | | | | | | | | | | | | | | | | | | | | | | | | | | | | | | | | | | | | | | |
| H71 | See Note 2. | | | | | | | | | | | | | | | | | | | | | | | | | | | | | | | | | | | | | | | | | | | | |
| H80 | Gain for Suppression of Output Current Fluctuation | 0.00 to 0.20 | 0.01 | — | 0.20 | | | | | | | | | | | | | | | | | | | | | | | | | | | | | | | | | | | | | | | | |
| H95 | See Note 2. | | | | | | | | | | | | | | | | | | | | | | | | | | | | | | | | | | | | | | | | | | | | |
| H96 | STOP Key Priority / Start Check Function | <table border="1"> <thead> <tr> <th>Item</th> <th>Data</th> <th>0</th> <th>1</th> <th>2</th> <th>3</th> </tr> </thead> <tbody> <tr> <td>STOP key priority function</td> <td></td> <td>OFF</td> <td>ON</td> <td>OFF</td> <td>ON</td> </tr> <tr> <td>Start check function</td> <td></td> <td>OFF</td> <td>OFF</td> <td>ON</td> <td>ON</td> </tr> </tbody> </table> | Item | Data | 0 | 1 | 2 | 3 | STOP key priority function | | OFF | ON | OFF | ON | Start check function | | OFF | OFF | ON | ON | — | — | 3 | | | | | | | | | | | | | | | | | | | | | | |
| Item | Data | 0 | 1 | 2 | 3 | | | | | | | | | | | | | | | | | | | | | | | | | | | | | | | | | | | | | | | | |
| STOP key priority function | | OFF | ON | OFF | ON | | | | | | | | | | | | | | | | | | | | | | | | | | | | | | | | | | | | | | | | |
| Start check function | | OFF | OFF | ON | ON | | | | | | | | | | | | | | | | | | | | | | | | | | | | | | | | | | | | | | | | |
| H97 | Clear Alarm Data | Returns to zero after data clear by H97 setting at 1. | — | — | 0 | | | | | | | | | | | | | | | | | | | | | | | | | | | | | | | | | | | | | | | | |
| H98 | Protection/Maintenance Function | <table border="1"> <thead> <tr> <th>Item</th> <th>Data</th> <th>0</th> <th>1</th> <th>2</th> <th>3</th> <th>4</th> <th>5</th> <th>6</th> <th>7</th> </tr> </thead> <tbody> <tr> <td>Carrier frequency automatic DEC function</td> <td></td> <td>OFF</td> <td>ON</td> <td>OFF</td> <td>ON</td> <td>OFF</td> <td>ON</td> <td>OFF</td> <td>ON</td> </tr> <tr> <td>Input phase loss protection *)</td> <td></td> <td>OFF</td> <td>OFF</td> <td>ON</td> <td>ON</td> <td>OFF</td> <td>OFF</td> <td>ON</td> <td>ON</td> </tr> <tr> <td>Output phase loss protection</td> <td></td> <td>OFF</td> <td>OFF</td> <td>OFF</td> <td>OFF</td> <td>ON</td> <td>ON</td> <td>ON</td> <td>ON</td> </tr> </tbody> </table> | Item | Data | 0 | 1 | 2 | 3 | 4 | 5 | 6 | 7 | Carrier frequency automatic DEC function | | OFF | ON | OFF | ON | OFF | ON | OFF | ON | Input phase loss protection *) | | OFF | OFF | ON | ON | OFF | OFF | ON | ON | Output phase loss protection | | OFF | OFF | OFF | OFF | ON | ON | ON | ON | — | — | 3 |
| Item | Data | 0 | 1 | 2 | 3 | 4 | 5 | 6 | 7 | | | | | | | | | | | | | | | | | | | | | | | | | | | | | | | | | | | | |
| Carrier frequency automatic DEC function | | OFF | ON | OFF | ON | OFF | ON | OFF | ON | | | | | | | | | | | | | | | | | | | | | | | | | | | | | | | | | | | | |
| Input phase loss protection *) | | OFF | OFF | ON | ON | OFF | OFF | ON | ON | | | | | | | | | | | | | | | | | | | | | | | | | | | | | | | | | | | | |
| Output phase loss protection | | OFF | OFF | OFF | OFF | ON | ON | ON | ON | | | | | | | | | | | | | | | | | | | | | | | | | | | | | | | | | | | | |

Application Functions: J Codes

| Func. code | Name | Data setting range | Min. | Unit | Factory setting |
|------------|--------------------------|--|-------|-------|-----------------|
| J01 | PID Control | 0 : Inactive 1 : Process control use (Normal action) 2 : Process control use (Inverse action) | — | — | 0 |
| J02 | (Remote process command) | 0 : Keypad 1 : PID process command 1 4 : Communication | — | — | 0 |
| J03 | P (Gain) | 0.000 to 10.000 times | 0.001 | Times | 0.100 |
| J04 | I (Integration time) | 0.0 to 3600.0s | 0.1 | s | 0.0 |
| J05 | D (Differentiation time) | 0.00 to 600.00s | 0.01 | s | 0.00 |
| J06 | (Feedback filter) | 0.0 to 900.0s | 0.1 | s | 0.5 |

Link Functions: y Codes

| Func. code | Name | Data setting range | Min. | Unit | Factory setting |
|------------|---|--|------|------|-----------------|
| y01 | RS485 Communication (Station address) | 1 to 255 | 1 | — | 1 |
| y02 | (Mode selection on no response error) | 0 : Trip and alarm <i>E-r-B</i> 1 : Operation for y03 timer, alarm <i>E-r-B</i> 2 : Operation for y03 timer, and retry to communicate. If retry fails, the inverter trips <i>E-r-B</i> 3 : Continuous operation | — | — | 0 |
| y03 | (Timer) | 0.0 to 60.0s | 0.1 | s | 2.0 |
| y04 | (Baud rate) | 0 : 2400bps 1 : 4800 2 : 9600 3 : 19200 | — | — | 3 |
| y05 | (Data length) | 0 : 8 bit 1 : 7 bit | — | — | 0 |
| y06 | (Parity check) | 0 : No checking 1 : Even parity 2 : Odd parity | — | — | 0 |
| y07 | (Stop bits) | 0 : 2 bits 1 : 1 bit | — | — | 0 |
| y08 | (No response error detection time) | 0 : No detection 1 : 1 to 60s | 1 | s | 0 |
| y09 | (Response interval) | 0.00 to 1.00s | 0.01 | s | 0.01 |
| y10 | (Protocol selection) | 0 : Modbus RTU protocol 1 : SX protocol (Loader protocol) 2 : Fuji general-purpose inverter protocol | — | — | 0 |
| y99 | Link Function for Supporting Data Input | (Freq. setting) (OPR command) 0 : by H30 by H30 1 : from RS-485 by H30 2 : by H30 from RS-485 3 : from RS-485 from RS-485 | — | — | 0 |

Note 1: The above setting ranges may be limited by the signs or the number of digits.

Note 2: Do not change the settings in *H71* and *H95*, as inverter does not use them although they are displayed.

<Changing, reflecting or storing data during operation>



: Disable : Change with keys and then save or reflect with key. : Change or reflect with keys and then save with key.

*) This function is OFF for single-phase series regardless of the settings.

Protective Functions

Protective Functions

The Compact Inverter *FRENIC-Mini*

| Function | Description | LED monitor | Alarm output (30A,B,C) Note | Related function code | |
|--|--|--|-----------------------------|----------------------------------|--------------------|
| Overcurrent Protection | <ul style="list-style-type: none"> Stops the inverter output to protect the inverter from an overcurrent resulting from overload. Stops the inverter output to protect the inverter from an overcurrent due to a short-circuit in the output circuit. Stops the inverter output to protect the inverter from an overcurrent due to a ground fault in the output circuit. This protection is effective only when the inverter starts. If you turn on the inverter without removing the ground fault, this protection may not work. | During acceleration | OC1 | ○ | |
| | | During deceleration | OC2 | | |
| | | While running at constant speed | OC3 | | |
| Overvoltage protection | The inverter stops the inverter output upon detecting an overvoltage condition (400V DC for three-phase 230 V, single-phase 230 V, and single-phase 115 V class series; 800 V DC for three-phase 460 V class series) in the DC link bus. This protection is not assured if excess AC line voltage is applied inadvertently. | During acceleration | OU1 | ○ | |
| | | During deceleration | OU2 | | |
| | | While running at constant speed(Stopped) | OU3 | | |
| Undervoltage protection | Stops the inverter output when the DC link bus voltage drops below the undervoltage level (200 V DC for three-phase 230 V, single-phase 230 V, and single-phase 115 V class series; 400 V DC for three-phase 460 V class series). However, if data "4 or 5" is selected for F14, no alarm is output even if the DC link bus voltage drops. | LU | △ | F14 | |
| Input phase loss protection | Detects input phase loss, stopping the inverter output. This function prevents the inverter from undergoing heavy stress that may be caused by input phase loss or interphase voltage unbalance and may damage the inverter. If connected load is light or a DC reactor is connected to the inverter, this function will not detect input phase loss if any. In single-phase series of inverters, this function is disabled by factory default. | L in | ○ | H98 | |
| Output phase loss protection | Detects breaks in inverter output wiring at the start of running and during running, stopping the inverter output. | OPL | ○ | H98 | |
| Overheat protection | Inverter | Stops the inverter when it detects excess heat sink temperature in case of cooling fan failure or overload. | OH1 | ○ | H43 |
| | Braking resistor | <ul style="list-style-type: none"> When the built-in or external braking resistor overheats, the inverter stops running. * It is necessary to set the function code corresponding to the braking resistor used (built-in or external). | dbR | ○ | F50,F51 |
| Overload protection | Calculates the IGBT internal temperature from the output current and internal temperature detection, stopping the inverter. | OLU | ○ | | |
| Motor protection | Electronic thermal overload relay | The inverter stops running the motor to protect the motor in accordance with the electronic thermal function setting. <ul style="list-style-type: none"> Protection of a standard motor over the entire frequency range. Protects the inverter motor over the entire frequency range. * The operation level and thermal time constant can be set. | OL1 | ○ | F10 |
| | PTC thermistor | A PTC thermistor input stops the inverter to protect the motor. A PTC thermistor is connected between terminals C1 and 11, and a 1kΩ external resistor is connected between terminals 13 and C1. | OH4 | ○ | F11,F12 H26,H27 |
| | Overload early warning | Outputs a preliminary alarm at a preset level before the inverter is stopped by the electronic thermal function for the purpose of protecting the motor. | — | — | E34,E35 |
| Stall prevention | Operates when the instantaneous overcurrent hits the set limit. Instantaneous overcurrent limit: Operates if the inverter output current exceeds the instantaneous overcurrent limit to prevent the inverter from tripping (during acceleration or negative constant speed operation). | — | — | H12 | |
| External alarm input | Stops the inverter with an alarm through the digital input signal (THR). | OH2 | ○ | E01 to E03 E98, E99 | |
| Alarm relay output (for any fault) | <ul style="list-style-type: none"> The inverter outputs a relay contact signal when the inverter issues an alarm and stopped. <Alarm reset> The alarm stop state is reset by pressing the  key or by the digital input signal (RST). <Saving the alarm history and detailed data> The information on the previous 4 alarms can be saved and displayed. | — | ○ | E20,E27 E01 to E03 E98,E99 | |
| Memory error | The inverter checks memory data after power-on and when the data is written. If a memory error is detected, the inverter stops. | Er1 | ○ | | |
| Remote keypad communication error | The inverter stops by detecting a communication error between the inverter and the remote keypad (option) during operation from the remote keypad. | Er2 | ○ | F02 | |
| CPU error | If the inverter detects a CPU error caused by noise or some other factor, the inverter stops. | Er3 | ○ | | |
| Operation error | STOP key priority | Pressing  key on the keypad forces the inverter to decelerate and stop the motor even if the inverter is running by any run commands given via the terminals or communications (link operation). After the motor stops, the inverter issues alarm "Er6." | Er6 | ○ | H96 |
| | Start check function | Inverters prohibit any run operations and displays "Er6" on the LED of keypad if any run command is given when: <ul style="list-style-type: none"> Powering up Releasing an alarm ( key turned on) Link command (LE) has switched inverter operations | | | |
| RS-485 communication error | On detecting an RS-485 communication error, the inverter displays the error code. | Er8 | ○ | | |
| Data save error during undervoltage | If the data could not be saved during activation of the undervoltage protection function, the inverter displays the error code. | ErF | ○ | | |

Note) A △ in the alarm output (30A,B,C) column indicates that there are cases where an alarm is not output in accordance with the function code.

Option Guide

The Compact Inverter FRENIC-Mini

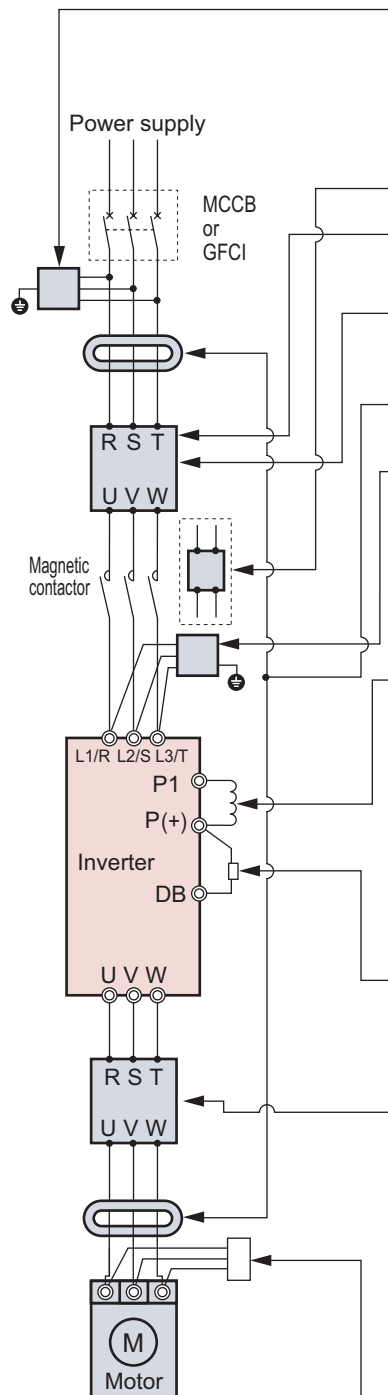

| Name | Function |
|---|--|
| Surge absorber | Suppresses surges or noise invading from an external source, preventing malfunction from magnetic contactors, control relays and timers, etc. |
| Arrester | Suppresses induced lightning surges from power source, thus protecting all equipment connected to the power source. |
| Surge killer | Absorbs surges or noise invading from an external source, preventing malfunction of electronic equipment used in the switchboard. |
| Frequency setting device | Frequency setting potentiometer (mounted externally) |
| Frequency meter | Displays the frequency in accordance with signals output from the inverter. |
| Option for single-phase 115V input | This is used in cases where a single-phase 115V power supply is used to feed a three-phase 230V inverter. (It can be applied to the inverter of 1HP or less.) |
| EMC compliance filter | This is a dedicated filter which complies with the European EMC (Emission) Directive. |
| AC REACTOR (ACR) | Used for power factor improvement and power supply coordination. However, it is recommended that a DC REACTOR with a higher efficiency and which is more compact and lightweight be used. Use a DC REACTOR (DCR) as a countermeasure for harmonics. If it is necessary to supply a stabilized power supply, such as a DC bus system and running from that (PN connection operation), please use such a reactor. |
| Ferrite ring for reducing radio noise | Reduces radio frequency noise. If the wiring between motor and inverter is shorter than 66ft (20m), use the ferrite ring in the power supply side. If longer than 66ft (20m), use it in the output side. |
| Filter capacitor for reducing radio interference | Reduces noise. For frequencies in the AM radio frequency band of 1MHz or less, a noise reduction effect can be obtained. Absolutely never connect this device to the inverter's output side. |
| DC REACTOR (DCR) | <p>[Use the DCR to normalize the power supply in the following cases.]</p> <ol style="list-style-type: none"> The power transformer capacity is 500kVA or over and exceeds the inverter rated capacity by 10 times. The inverter and a thyristor converter are connected with the same transformer. <p>*Check if the thyristor converter uses a commutation reactor. If not, AC reactor must be connected to the power supply side.</p> Overvoltage trip occurs due to open/close of the phase-advancing capacitor for the power supply lines. The voltage unbalance exceeds 2%. $\text{Voltage unbalance (\%)} = \frac{\text{Max. voltage [V]} - \text{Min. Voltage [V]}}{\text{Three-phase average voltage [V]}} \times 67$ <p>(IEC 61800-3 (5.2.3))</p> <p>[For improving input power-factor, reducing harmonics] • Used to reduce input harmonic current (correcting power-factor)</p> |
| Braking resistor | Used to increase the braking capability when the motor needs to start and stop frequently or when the moment of inertia is large. |
| Output circuit filter | <p>This filter is connected to the output circuit of inverters, and has the following functions:</p> <ol style="list-style-type: none"> Suppressing fluctuation of motor terminal voltage Protects the motor insulation from being damaged by surge voltage. Suppressing leakage current from output side wiring Reduces the leakage current caused when several motors are operated in parallel or connected with long wiring. Suppressing radiation noise or inductive noise from output side wiring Effective noise suppression device for long wiring applications such as plant * There are two kinds of filters for 460V series. Choose a desired one according to the purpose of use. |
| RS-485 communications card | This makes communication to a PLC or personal computer system easy. |
| Extension cable for remote operation | Used to connect the RS-485 communications card with the remote keypad, USB-RS-485 converter, etc. |
| Remote keypad | Used when performing inverter remote operations with the remote keypad. |
| Copy adaptor | Allows copying data to several inverters with easy connection to the inverter body. |
| Connector adaptor | Used for the connector replacement of the copy adaptor. |
| Inverter support loader software | Inverter support loader software, Windows based, that makes setting of function codes easy. |
| USB-RS-485 converter | Used to connect the RS-485 communications card with a USB port of your personal computer. |
| NEMA1 kit | NEMA1 kit protects the inverter body with the structure that conforms to the NEMA1 standard (approved as UL TYPE1). |
| Attachments | Permit change of protective structure, replacement of Fuji's previous inverter model and installation on the DIN rails, etc. |
| Surge suppression unit SSSU-□□□□TA-NS | Prevents the motor insulation from being damaged by the surge current of the inverter. |

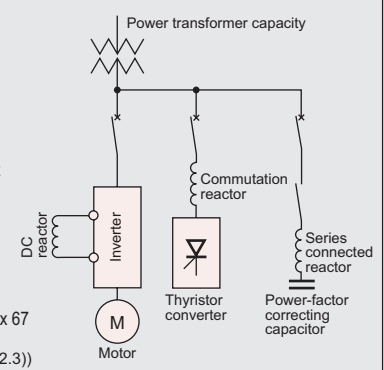

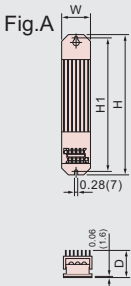
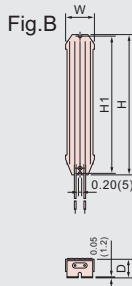
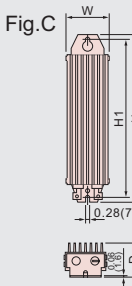
| Name(Type) | | Specifications and dimensions | | | | | | | | | | [Unit : inch (mm)] | | | | | | | | | | | | | | | | | | | | | | | | | | | | | | | | | | | | | | | | | | | | | | | | | | | | | | | | | | | | | | | | | | | | | | | | | | | | | | | | | | | |
|--|--|---|---|---|---|--------------|--------------|--------------|------------------------|-------------|-------------|--------------------|----------------|--|--|------|--|------|------------------------|--|--|--|----------------|------|------|---|---|----|---|---------------|----------|----------|---|-----------|-------------|-------------|-----------|------------|---------|---|---|-----------|-------------|-------------|-----------|------------|---|---------|---|-----------|-------------|-------------|-----------|------------|---------|---|---|-----------|-------------|-------------|-----------|------------|------------|---|---------|---|-----------|-------------|-------------|-----------|------------|-----------|-----------|---|-----------|------------|------------|-----------|------------|----------|----------|---|-----------|------------|------------|-----------|------------|----------|----------|---|-----------|-------------|-------------|-----------|------------|
| Braking resistor [Standard type] (DB□□□-2) (DB□□□-4) [10%ED type] (DB□□□-2C) (DB□□□-4C) |  |  |  |  | <table border="1"> <thead> <tr> <th rowspan="2"></th> <th colspan="2">Type</th> <th rowspan="2">Fig.</th> <th colspan="4">Dimensions [inch (mm)]</th> <th rowspan="2">Mass [lbs(kg)]</th> </tr> <tr> <th>230V</th> <th>460V</th> <th>W</th> <th>H</th> <th>H1</th> <th>D</th> </tr> </thead> <tbody> <tr> <td rowspan="4">Standard type</td> <td>DB0.75-2</td> <td>DB0.75-4</td> <td>A</td> <td>2.52 (64)</td> <td>12.20 (310)</td> <td>11.61 (295)</td> <td>2.64 (67)</td> <td>2.87 (1.3)</td> </tr> <tr> <td>DB2.2-2</td> <td>-</td> <td>A</td> <td>2.99 (76)</td> <td>13.58 (345)</td> <td>13.07 (332)</td> <td>3.70 (94)</td> <td>4.41 (2.0)</td> </tr> <tr> <td>-</td> <td>DB2.2-4</td> <td>A</td> <td>2.52 (64)</td> <td>18.50 (470)</td> <td>17.91 (455)</td> <td>2.64 (67)</td> <td>4.41 (2.0)</td> </tr> <tr> <td>DB3.7-2</td> <td>-</td> <td>A</td> <td>2.99 (76)</td> <td>13.58 (345)</td> <td>13.07 (332)</td> <td>3.70 (94)</td> <td>4.41 (2.0)</td> </tr> <tr> <td rowspan="4">10%ED type</td> <td>-</td> <td>DB3.7-4</td> <td>A</td> <td>2.52 (64)</td> <td>18.50 (470)</td> <td>17.91 (455)</td> <td>2.64 (67)</td> <td>3.75 (1.7)</td> </tr> <tr> <td>DB0.75-2C</td> <td>DB0.75-4C</td> <td>B</td> <td>1.69 (43)</td> <td>8.70 (221)</td> <td>8.46 (215)</td> <td>3.70 (94)</td> <td>4.41 (2.0)</td> </tr> <tr> <td>DB2.2-2C</td> <td>DB2.2-4C</td> <td>C</td> <td>2.64 (67)</td> <td>7.40 (188)</td> <td>6.77 (172)</td> <td>2.17 (55)</td> <td>1.76 (0.8)</td> </tr> <tr> <td>DB3.7-2C</td> <td>DB3.7-4C</td> <td>C</td> <td>2.64 (67)</td> <td>12.91 (328)</td> <td>12.28 (312)</td> <td>2.17 (55)</td> <td>3.53 (1.6)</td> </tr> </tbody> </table> | | | | | | | | | | | Type | | Fig. | Dimensions [inch (mm)] | | | | Mass [lbs(kg)] | 230V | 460V | W | H | H1 | D | Standard type | DB0.75-2 | DB0.75-4 | A | 2.52 (64) | 12.20 (310) | 11.61 (295) | 2.64 (67) | 2.87 (1.3) | DB2.2-2 | - | A | 2.99 (76) | 13.58 (345) | 13.07 (332) | 3.70 (94) | 4.41 (2.0) | - | DB2.2-4 | A | 2.52 (64) | 18.50 (470) | 17.91 (455) | 2.64 (67) | 4.41 (2.0) | DB3.7-2 | - | A | 2.99 (76) | 13.58 (345) | 13.07 (332) | 3.70 (94) | 4.41 (2.0) | 10%ED type | - | DB3.7-4 | A | 2.52 (64) | 18.50 (470) | 17.91 (455) | 2.64 (67) | 3.75 (1.7) | DB0.75-2C | DB0.75-4C | B | 1.69 (43) | 8.70 (221) | 8.46 (215) | 3.70 (94) | 4.41 (2.0) | DB2.2-2C | DB2.2-4C | C | 2.64 (67) | 7.40 (188) | 6.77 (172) | 2.17 (55) | 1.76 (0.8) | DB3.7-2C | DB3.7-4C | C | 2.64 (67) | 12.91 (328) | 12.28 (312) | 2.17 (55) | 3.53 (1.6) |
| | | | | | | Type | | Fig. | Dimensions [inch (mm)] | | | | Mass [lbs(kg)] | | | | | | | | | | | | | | | | | | | | | | | | | | | | | | | | | | | | | | | | | | | | | | | | | | | | | | | | | | | | | | | | | | | | | | | | | | | | | | | | | | |
| | | | | | | 230V | 460V | | W | H | H1 | D | | | | | | | | | | | | | | | | | | | | | | | | | | | | | | | | | | | | | | | | | | | | | | | | | | | | | | | | | | | | | | | | | | | | | | | | | | | | | | | | | | | |
| | | | | | Standard type | DB0.75-2 | DB0.75-4 | A | 2.52 (64) | 12.20 (310) | 11.61 (295) | 2.64 (67) | 2.87 (1.3) | | | | | | | | | | | | | | | | | | | | | | | | | | | | | | | | | | | | | | | | | | | | | | | | | | | | | | | | | | | | | | | | | | | | | | | | | | | | | | | | | | |
| | | | | | | DB2.2-2 | - | A | 2.99 (76) | 13.58 (345) | 13.07 (332) | 3.70 (94) | 4.41 (2.0) | | | | | | | | | | | | | | | | | | | | | | | | | | | | | | | | | | | | | | | | | | | | | | | | | | | | | | | | | | | | | | | | | | | | | | | | | | | | | | | | | | |
| | | | | | | - | DB2.2-4 | A | 2.52 (64) | 18.50 (470) | 17.91 (455) | 2.64 (67) | 4.41 (2.0) | | | | | | | | | | | | | | | | | | | | | | | | | | | | | | | | | | | | | | | | | | | | | | | | | | | | | | | | | | | | | | | | | | | | | | | | | | | | | | | | | | |
| | | | | | | DB3.7-2 | - | A | 2.99 (76) | 13.58 (345) | 13.07 (332) | 3.70 (94) | 4.41 (2.0) | | | | | | | | | | | | | | | | | | | | | | | | | | | | | | | | | | | | | | | | | | | | | | | | | | | | | | | | | | | | | | | | | | | | | | | | | | | | | | | | | | |
| | | | | | 10%ED type | - | DB3.7-4 | A | 2.52 (64) | 18.50 (470) | 17.91 (455) | 2.64 (67) | 3.75 (1.7) | | | | | | | | | | | | | | | | | | | | | | | | | | | | | | | | | | | | | | | | | | | | | | | | | | | | | | | | | | | | | | | | | | | | | | | | | | | | | | | | | | |
| | | | | | | DB0.75-2C | DB0.75-4C | B | 1.69 (43) | 8.70 (221) | 8.46 (215) | 3.70 (94) | 4.41 (2.0) | | | | | | | | | | | | | | | | | | | | | | | | | | | | | | | | | | | | | | | | | | | | | | | | | | | | | | | | | | | | | | | | | | | | | | | | | | | | | | | | | | |
| | | | | | | DB2.2-2C | DB2.2-4C | C | 2.64 (67) | 7.40 (188) | 6.77 (172) | 2.17 (55) | 1.76 (0.8) | | | | | | | | | | | | | | | | | | | | | | | | | | | | | | | | | | | | | | | | | | | | | | | | | | | | | | | | | | | | | | | | | | | | | | | | | | | | | | | | | | |
| DB3.7-2C | DB3.7-4C | C | 2.64 (67) | 12.91 (328) | | 12.28 (312) | 2.17 (55) | 3.53 (1.6) | | | | | | | | | | | | | | | | | | | | | | | | | | | | | | | | | | | | | | | | | | | | | | | | | | | | | | | | | | | | | | | | | | | | | | | | | | | | | | | | | | | | | | | |
| Standard type | Three-phase 230V | FRNF50C1□-2U** | DB0.75-2 | 1 | 100 | 35.6 (4.02) | 29.4 (3.32) | 9 | 45 | 0.06 | 22 | | | | | | | | | | | | | | | | | | | | | | | | | | | | | | | | | | | | | | | | | | | | | | | | | | | | | | | | | | | | | | | | | | | | | | | | | | | | | | | | | | | | |
| | | FRNF50C1□-4U** | DB0.75-4 | 1 | 200 | 35.6 (4.02) | 29.4 (3.32) | 9 | 45 | 0.06 | 22 | | | | | | | | | | | | | | | | | | | | | | | | | | | | | | | | | | | | | | | | | | | | | | | | | | | | | | | | | | | | | | | | | | | | | | | | | | | | | | | | | | | | |
| | | FRN001C1□-2U** | DB0.75-2 | 1 | 150 | 67.0 (7.57) | 55.3 (6.25) | 17 | 45 | 0.09 | 18 | | | | | | | | | | | | | | | | | | | | | | | | | | | | | | | | | | | | | | | | | | | | | | | | | | | | | | | | | | | | | | | | | | | | | | | | | | | | | | | | | | | | |
| | | FRN002C1□-2U** | DB2.2-2 | 1 | 40 | 132.8 (15.0) | 109.7 (12.4) | 34 | 45 | 0.10 | 10 | | | | | | | | | | | | | | | | | | | | | | | | | | | | | | | | | | | | | | | | | | | | | | | | | | | | | | | | | | | | | | | | | | | | | | | | | | | | | | | | | | | | |
| | | FRN003C1□-2U** | DB2.2-2 | 1 | 40 | 194.7 (22.0) | 161.1 (18.2) | 33 | 30 | 0.10 | 7 | | | | | | | | | | | | | | | | | | | | | | | | | | | | | | | | | | | | | | | | | | | | | | | | | | | | | | | | | | | | | | | | | | | | | | | | | | | | | | | | | | | | |
| | | FRN005C1□-2U** | DB3.7-2 | 1 | 33 | 328.4 (37.1) | 269.9 (30.5) | 37 | 20 | 0.12 | 5 | | | | | | | | | | | | | | | | | | | | | | | | | | | | | | | | | | | | | | | | | | | | | | | | | | | | | | | | | | | | | | | | | | | | | | | | | | | | | | | | | | | | |
| | | FRNF50C1□-4U** | DB0.75-4 | 1 | 200 | 35.6 (4.02) | 29.4 (3.32) | 9 | 45 | 0.06 | 22 | | | | | | | | | | | | | | | | | | | | | | | | | | | | | | | | | | | | | | | | | | | | | | | | | | | | | | | | | | | | | | | | | | | | | | | | | | | | | | | | | | | | |
| | | FRN001C1□-4U** | DB0.75-4 | 1 | 150 | 67.0 (7.57) | 55.3 (6.25) | 17 | 45 | 0.09 | 18 | | | | | | | | | | | | | | | | | | | | | | | | | | | | | | | | | | | | | | | | | | | | | | | | | | | | | | | | | | | | | | | | | | | | | | | | | | | | | | | | | | | | |
| | | FRN002C1□-4U** | DB2.2-4 | 1 | 160 | 132.8 (15.0) | 109.7 (12.4) | 34 | 45 | 0.10 | 10 | | | | | | | | | | | | | | | | | | | | | | | | | | | | | | | | | | | | | | | | | | | | | | | | | | | | | | | | | | | | | | | | | | | | | | | | | | | | | | | | | | | | |
| | | FRN003C1□-4U** | DB2.2-4 | 1 | 160 | 194.7 (22.0) | 161.1 (18.2) | 33 | 30 | 0.10 | 7 | | | | | | | | | | | | | | | | | | | | | | | | | | | | | | | | | | | | | | | | | | | | | | | | | | | | | | | | | | | | | | | | | | | | | | | | | | | | | | | | | | | | |
| | | FRN005C1□-4U** | DB3.7-4 | 1 | 130 | 328.4 (37.1) | 269.9 (30.5) | 37 | 20 | 0.12 | 5 | | | | | | | | | | | | | | | | | | | | | | | | | | | | | | | | | | | | | | | | | | | | | | | | | | | | | | | | | | | | | | | | | | | | | | | | | | | | | | | | | | | | |
| | | Single-phase 230V | FRNF50C1□-7U | DB0.75-2 | 1 | 100 | 35.6 (4.02) | 29.4 (3.32) | 9 | 45 | 0.06 | 22 | | | | | | | | | | | | | | | | | | | | | | | | | | | | | | | | | | | | | | | | | | | | | | | | | | | | | | | | | | | | | | | | | | | | | | | | | | | | | | | | | | | |
| | FRN001C1□-7U | | DB0.75-2 | 1 | 150 | 67.0 (7.57) | 55.3 (6.25) | 17 | 45 | 0.09 | 18 | | | | | | | | | | | | | | | | | | | | | | | | | | | | | | | | | | | | | | | | | | | | | | | | | | | | | | | | | | | | | | | | | | | | | | | | | | | | | | | | | | | | |
| | FRN002C1□-7U | | DB2.2-2 | 1 | 40 | 132.8 (15.0) | 109.7 (12.4) | 34 | 45 | 0.10 | 10 | | | | | | | | | | | | | | | | | | | | | | | | | | | | | | | | | | | | | | | | | | | | | | | | | | | | | | | | | | | | | | | | | | | | | | | | | | | | | | | | | | | | |
| | FRN003C1□-7U | | DB2.2-2 | 1 | 40 | 194.7 (22.0) | 161.1 (18.2) | 33 | 30 | 0.10 | 7 | | | | | | | | | | | | | | | | | | | | | | | | | | | | | | | | | | | | | | | | | | | | | | | | | | | | | | | | | | | | | | | | | | | | | | | | | | | | | | | | | | | | |
| | FRNF50C1□-6U | | DB0.75-2 | 1 | 100 | 35.6 (4.02) | 29.4 (3.32) | 9 | 45 | 0.06 | 22 | | | | | | | | | | | | | | | | | | | | | | | | | | | | | | | | | | | | | | | | | | | | | | | | | | | | | | | | | | | | | | | | | | | | | | | | | | | | | | | | | | | | |
| | FRN001C1□-6U | | DB0.75-2 | 1 | 150 | 67.0 (7.57) | 55.3 (6.25) | 17 | 45 | 0.09 | 7 | | | | | | | | | | | | | | | | | | | | | | | | | | | | | | | | | | | | | | | | | | | | | | | | | | | | | | | | | | | | | | | | | | | | | | | | | | | | | | | | | | | | |
| | 10%ED type | Three-phase 230V | FRNF50C1□-2U** | DB0.75-2C | 1 | 100 | 35.6 (4.02) | 29.4 (3.32) | 50 | 250 | 0.10 | 37 | | | | | | | | | | | | | | | | | | | | | | | | | | | | | | | | | | | | | | | | | | | | | | | | | | | | | | | | | | | | | | | | | | | | | | | | | | | | | | | | | | | |
| | | | FRNF50C1□-4U** | DB0.75-4C | 1 | 200 | 35.6 (4.02) | 29.4 (3.32) | 50 | 250 | 0.10 | 37 | | | | | | | | | | | | | | | | | | | | | | | | | | | | | | | | | | | | | | | | | | | | | | | | | | | | | | | | | | | | | | | | | | | | | | | | | | | | | | | | | | | |
| | | | FRN001C1□-2U** | DB0.75-2C | 1 | 150 | 67.0 (7.57) | 55.3 (6.25) | 50 | 133 | 0.10 | 20 | | | | | | | | | | | | | | | | | | | | | | | | | | | | | | | | | | | | | | | | | | | | | | | | | | | | | | | | | | | | | | | | | | | | | | | | | | | | | | | | | | | |
| | | | FRN002C1□-2U** | DB2.2-2C | 1 | 40 | 132.8 (15.0) | 109.7 (12.4) | 55 | 73 | 0.15 | 14 | | | | | | | | | | | | | | | | | | | | | | | | | | | | | | | | | | | | | | | | | | | | | | | | | | | | | | | | | | | | | | | | | | | | | | | | | | | | | | | | | | | |
| | | Three-phase 460V | FRN003C1□-2U** | DB2.2-2C | 1 | 40 | 194.7 (22.0) | 161.1 (18.2) | 55 | 50 | 0.15 | 10 | | | | | | | | | | | | | | | | | | | | | | | | | | | | | | | | | | | | | | | | | | | | | | | | | | | | | | | | | | | | | | | | | | | | | | | | | | | | | | | | | | | |
| | | | FRN005C1□-2U** | DB3.7-2C | 1 | 33 | 328.4 (37.1) | 269.9 (30.5) | 140 | 75 | 0.25 | 10 | | | | | | | | | | | | | | | | | | | | | | | | | | | | | | | | | | | | | | | | | | | | | | | | | | | | | | | | | | | | | | | | | | | | | | | | | | | | | | | | | | | |
| | | | FRNF50C1□-4U** | DB0.75-4C | 1 | 200 | 35.6 (4.02) | 29.4 (3.32) | 50 | 250 | 0.10 | 37 | | | | | | | | | | | | | | | | | | | | | | | | | | | | | | | | | | | | | | | | | | | | | | | | | | | | | | | | | | | | | | | | | | | | | | | | | | | | | | | | | | | |
| FRN001C1□-4U** | | | DB0.75-4C | 1 | 150 | 67.0 (7.57) | 55.3 (6.25) | 50 | 133 | 0.10 | 20 | | | | | | | | | | | | | | | | | | | | | | | | | | | | | | | | | | | | | | | | | | | | | | | | | | | | | | | | | | | | | | | | | | | | | | | | | | | | | | | | | | | | |
| Single-phase 230V | | FRN002C1□-4U** | DB2.2-4C | 1 | 160 | 132.8 (15.0) | 109.7 (12.4) | 55 | 73 | 0.15 | 14 | | | | | | | | | | | | | | | | | | | | | | | | | | | | | | | | | | | | | | | | | | | | | | | | | | | | | | | | | | | | | | | | | | | | | | | | | | | | | | | | | | | | |
| | | FRN003C1□-4U** | DB2.2-4C | 1 | 160 | 194.7 (22.0) | 161.1 (18.2) | 55 | 50 | 0.15 | 10 | | | | | | | | | | | | | | | | | | | | | | | | | | | | | | | | | | | | | | | | | | | | | | | | | | | | | | | | | | | | | | | | | | | | | | | | | | | | | | | | | | | | |
| | | FRN005C1□-4U** | DB3.7-4C | 1 | 130 | 328.4 (37.1) | 269.9 (30.5) | 140 | 75 | 0.25 | 10 | | | | | | | | | | | | | | | | | | | | | | | | | | | | | | | | | | | | | | | | | | | | | | | | | | | | | | | | | | | | | | | | | | | | | | | | | | | | | | | | | | | | |
| | | FRNF50C1□-7U | DB0.75-2C | 1 | 100 | 35.6 (4.02) | 29.4 (3.32) | 50 | 250 | 0.10 | 37 | | | | | | | | | | | | | | | | | | | | | | | | | | | | | | | | | | | | | | | | | | | | | | | | | | | | | | | | | | | | | | | | | | | | | | | | | | | | | | | | | | | | |
| Single-phase 115V | FRN001C1□-7U | DB0.75-2C | 1 | 150 | 67.0 (7.57) | 55.3 (6.25) | 50 | 133 | 0.10 | 20 | | | | | | | | | | | | | | | | | | | | | | | | | | | | | | | | | | | | | | | | | | | | | | | | | | | | | | | | | | | | | | | | | | | | | | | | | | | | | | | | | | | | | |
| | FRN002C1□-7U | DB2.2-2C | 1 | 40 | 132.8 (15.0) | 109.7 (12.4) | 55 | 73 | 0.15 | 14 | | | | | | | | | | | | | | | | | | | | | | | | | | | | | | | | | | | | | | | | | | | | | | | | | | | | | | | | | | | | | | | | | | | | | | | | | | | | | | | | | | | | | |
| | FRN003C1□-7U | DB2.2-2C | 1 | 40 | 194.7 (22.0) | 161.1 (18.2) | 55 | 50 | 0.15 | 10 | | | | | | | | | | | | | | | | | | | | | | | | | | | | | | | | | | | | | | | | | | | | | | | | | | | | | | | | | | | | | | | | | | | | | | | | | | | | | | | | | | | | | |
| | FRNF50C1□-6U | DB0.75-2C | 1 | 100 | 35.6 (4.02) | 29.4 (3.32) | 50 | 250 | 0.10 | 37 | | | | | | | | | | | | | | | | | | | | | | | | | | | | | | | | | | | | | | | | | | | | | | | | | | | | | | | | | | | | | | | | | | | | | | | | | | | | | | | | | | | | | |
| FRN001C1□-6U | DB0.75-2C | 1 | 150 | 67.0 (7.57) | 55.3 (6.25) | 50 | 133 | 0.10 | 20 | | | | | | | | | | | | | | | | | | | | | | | | | | | | | | | | | | | | | | | | | | | | | | | | | | | | | | | | | | | | | | | | | | | | | | | | | | | | | | | | | | | | | | |

| **Braking resistor** [Compact type] (TK80W120Ω) | | | | | | | | | | | | Unit : inch (mm) | |
| | Series | Type | TK80W120Ω | | | | | | | | | | | |------------------|---------------------|--|-----------------|-----------------|-----------------|-----------------|-----|--|--|--|--|--| | Three-phase 230V | Resistor | Capacity [kW] | 0.08 | | | | | | | | | | | | | Ohmic value [Ω] | 120 | | | | | | | | | | | | Applicable inverter | FRNF50 C1□-2U** | FRN001 C1□-2U** | FRN002 C1□-2U** | FRN003 C1□-2U** | FRN005 C1□-2U** | | | | | | | | | | Applied motor output [HP] | 1/2 | 1 | 2 | 3 | 5 | | | | | | | | | Average braking torque [%] | 150 | 130 | 100 | 65 | 45 | | | | | | | | | Ullowable Allowable duty cycle [%] | 15 | 5 | 5 | 5 | 5 | | | | | | | | | limits Continuous allowable braking time | 15s | 15s | 10s | 10s | 10s | | | | | | | | | | | | | | | | | |
| NOTE: This resistor is not applicable to 3-pahse 460V series. | | | | | | | | | | | |

Note) For the inverter type FRNF50C1□-2U**, the symbol □ is replaced with either of the following alphabets and ** is replaced with any of the following numeral codes:
 □ : S (Standard type), E (EMC filter built-in type), ** : 21 (Braking resistor built-in type), None (Standard type)
 The inverter applicable to RS-485 communication is limited to the standard ones in three-phase 230V and three-phase 460V series.
 The braking resistor built-in type is limited to the inverters for 2HP or larger.

Options

The Compact Inverter **FRENIC-Mini**

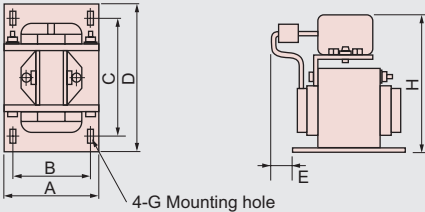
| Name | Dimension | | | | | | | | | | [Unit : inch (mm)] | | | | |
|--|--|-------------------|-------------------|--------------|--------------|-------------|--------------|---------------|----------|--------------|--------------------|----------------|---------------|----|-----------|
| DC REACTOR  |  | | | | | | | | | | | | | | |
| | Applicable inverter type | | | Reactor type | Dimensions | | | | | | Terminal screw | Mass [lbs(kg)] | | | |
| | Three-phase 230V | Single-phase 230V | Single-phase 115V | | A | B | C | D | E | G | | | H | | |
| | FRNF12C1□-2U** | FRNF12C1□-7U | | DCR2-0.2 | 2.6 (66) | 2.2 (56) | 2.83 (72) | 3.54 (90) | 0.2(5) | 0.2 (5.2) | x | 0.31 (8) | 3.7 (94) | M4 | 1.76(0.8) |
| | FRNF25C1□-2U** | FRNF25C1□-7U | | | | | | | DCR2-0.4 | | | | | | 0.59(15) |
| | FRNF50C1□-2U** | FRNF50C1□-7U | | DCR2-0.75 | 0.79(20) | 3.09(1.4) | | | | | | | | | |
| | FRN001C1□-2U** | FRNF50C1□-7U | FRNF12C1□-6U | DCR2-1.5 | | 3.53(1.6) | | | | | | | | | |
| | FRN002C1□-2U** | FRN001C1□-7U | FRNF25C1□-6U | DCR2-2.2 | 3.39 (86) | 2.8 (71) | 3.15 (80) | 3.94 (100) | 0.39(10) | 0.24 (6) | x | 0.35 (9) | 4.33 (110) | | 4.41(2.0) |
| | FRN003C1□-2U** | FRN002C1□-7U | FRNF50C1□-6U | DCR2-3.7 | 0.79(20) | 5.73(2.6) | | | | | | | | | |
| | Three-phase 460V series | | | | | | | | | | | | | M4 | |
| | FRNF50C1□-4U** | | | DCR4-0.4 | 0.59(15) | 2.21(1.0) | | | | | | | | | |
| | FRN001C1□-4U** | | | DCR4-0.75 | 0.79(20) | 3.09(1.4) | | | | | | | | | |
| | FRN002C1□-4U** | | | DCR4-1.5 | | 3.53(1.6) | | | | | | | | | |
| | FRN003C1□-4U** | | | DCR4-2.2 | | 4.41(2.0) | | | | | | | | | |
| | FRN005C1□-4U** | | | DCR4-3.7 | | 5.73(2.6) | | | | | | | | | |

Note) For the inverter type FRNF50C1□-2U**, the symbol □ is replaced with either of the following alphabets and ** is replaced with any of the following numeral codes:
 □ : S (Standard type), E (EMC filter built-in type), ** : 21 (Braking resistor built-in type), None (Standard type)
 The inverter applicable to RS-485 communication is limited to the standard ones in three-phase 230V and three-phase 460V series.
 The braking resistor built-in type is limited to the inverters for 2HP or larger.

Wiring equipment

The Compact Inverter **FRENIC-Mini**

| Power supply voltage | Nominal applied motor [HP] | Inverter type | MCCB or GFCI Rated current [A] | | Magnetic contactor (MC) | | | Recommended wire size [mm ²] | | | | | | |
|----------------------|----------------------------|----------------|--------------------------------|-----------------|-------------------------|-----------------|----------------|--|-----------------|------------------------|-----------------------------|-----|----|----|
| | | | With DCR | Without reactor | Input circuit | | Output circuit | Input circuit [L1/R, L2/S, L3/T] | | DCR circuit [P1, P(+)] | DB circuit [P(+), DB, N(-)] | | | |
| | | | | | With DCR | Without reactor | | With DCR | Without reactor | | | | | |
| Three-phase 230V | 1/8 | FRNF12C1□-2U** | 5 | 5 | SC-05 | SC-05 | SC-05 | 2.0 | 2.0 | 2.0 | 2.0 | 2.0 | | |
| | 1/4 | FRNF25C1□-2U** | | | | | | | | | | | | |
| | 1/2 | FRNF50C1□-2U** | | | | | | | | | | | | |
| | 1 | FRN001C1□-2U** | 10 | 10 | | | | | | | | | | |
| | 2 | FRN002C1□-2U** | | | | | | | | | | | | |
| | 3 | FRN003C1□-2U** | 20 | 30 | | | | | | | | | | |
| 5 | FRN005C1□-2U** | SC-5-1 | | | | | | | | | | | | |
| Three-phase 460V | 1/2 | FRNF50C1□-4U** | 5 | 5 | SC-05 | SC-05 | SC-05 | 2.0 | 2.0 | 2.0 | 2.0 | 2.0 | | |
| | 1 | FRN001C1□-4U** | | | | | | | | | | | | |
| | 2 | FRN002C1□-4U** | | | | | | | | | | | 10 | |
| | 3 | FRN003C1□-4U** | | | | | | | | | | | | |
| | 5 | FRN005C1□-4U** | | | | | | | | | | | 10 | 20 |
| Single-phase 230V | 1/8 | FRNF12C1□-7U | 5 | 5 | SC-05 | SC-05 | SC-05 | 2.0 | 2.0 | 2.0 | 2.0 | 2.0 | | |
| | 1/4 | FRNF25C1□-7U | | | | | | | | | | | | |
| | 1/2 | FRNF50C1□-7U | 10 | 15 | | | | | | | | | | |
| | 1 | FRN001C1□-7U | | | | | | | | | | | | |
| | 2 | FRN002C1□-7U | 15 | 20 | | | | | | | | | | |
| | 3 | FRN003C1□-7U | | | | | | | | | | | 20 | 30 |
| Single-phase 115V | 1/8 | FRNF12C1□-6U | 5 | 5 | SC-05 | SC-05 | SC-05 | 2.0 | 2.0 | 2.0 | 2.0 | 2.0 | | |
| | 1/4 | FRNF25C1□-6U | | | | | | | | | | | | |
| | 1/2 | FRNF50C1□-6U | | | | | | | | | | | 10 | 15 |
| | 1 | FRN001C1□-6U | | | | | | | | | | | | |

Note) For the inverter type FRNF50C1□-2U**, the symbol □ is replaced with either of the following letters and ** is replaced with any of the following numeral codes:
 □ : S (Standard type), E (EMC filter built-in type), ** : 21 (Braking resistor built-in type), None (Standard type)
 The inverter applicable to RS-485 communication is limited to the standard ones in three-phase 230V and three-phase 460V series.
 The braking resistor built-in type is limited to the inverters rated 2HP or larger.
 • For molded-case circuit breakers (MCCB) and a ground-fault circuit interrupter (GFCI), the required frame type and series depend on the facility transformer capacity and other factors. When selecting optimal breakers, refer to the relevant technical data. Also select the rated sensitive current of GFCI utilizing the technical data. The above rated currents of MCCB and GFCI are for the breakers SA□B/□ and SA□R/□.
 • The recommended wire sizes are based on the temperature inside the panel not exceeding 50°C (122°F).
 • The above wires are 600V HIV insulated solid wires (75°C (167°F)).
 • Data in the above table may differ according to environmental conditions (ambient temperature, power supply voltage, and other factors).

■ RS-485 communications card (OPC-C1-RS)

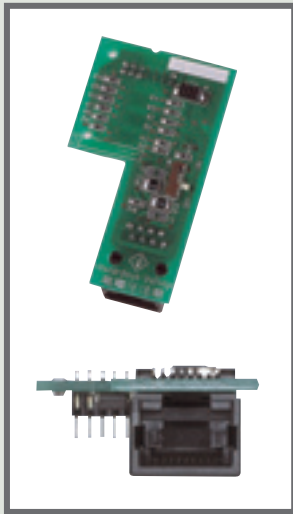

This is an exclusive option that enables the FRENIC-Mini series to use RS-485 communication.

The following operations can be performed from the remote keypad, or from a personal computer, PLC or other host controller using RS-485 communication.

- Operation functions such as frequency settings, forward, reverse, stop, coast-to-stop and reset.
- Monitoring of the output frequency, output current, operating status and alarm contents.
- Setting of function codes

<Transmission Specifications>

| Item | Specifications | | |
|---------------------------|--|---|--|
| Communications protocol | SX Protocol (Support loader exclusive) | Modbus RTU (Conforming to Modicon's Modbus RTU) | Fuji general-purpose inverter protocol |
| Electrical specifications | EIA RS-485 | | |
| Number of units connected | Host: 1 unit, Inverters: 31 units | | |
| Transmission speed | 19200, 9600, 4800, 2400bps | | |
| Synchronization system | Start-stop synchronous | | |
| Transmission method | Half-duplex | | |

■ Remote operation extension cable (CB-□S)

This straight cable is used to connect the RS-485 communications card and the remote keypad, and available in three lengths, i.e. 3.3ft, 9.8ft and 16.4ft (1m, 3m and 5m).



| Type | L |
|-------|-------------|
| CB-5S | 16.4ft (5m) |
| CB-3S | 9.8ft (3m) |
| CB-1S | 3.3ft (1m) |

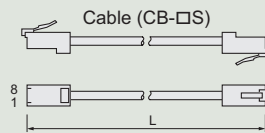

■ Remote keypad (TP-E1)

The keypad permits remote control of FRENIC-Mini, and function setting and display (with copy function).



■ Connector adaptor (CPAD-C1-CN)

This adaptor is a replaceable component of the copy adaptor's connector.



■ Copy adaptor (CPAD-C1)

The copy adaptor can be easily connected to an inverter, and is used to copy data to several inverters.



■ Rail mounting base (RMA-C1-□□□)

This is a base for mounting the inverter on a DIN rail (35mm wide).

| Option type | Applicable Inverter type |
|--------------|--------------------------|
| RMA-C1-0.75 | FRNF12C1S-2U** |
| | FRNF25C1S-2U** |
| | FRNF50C1S-2U** |
| | FRN001C1S-2U** |
| | FRNF12C1S-7U |
| | FRNF25C1S-7U |
| | FRNF50C1S-7U |
| | FRN001C1S-7U |
| | FRNF12C1E-2U |
| | FRNF25C1E-2U |
| FRNF50C1E-2U | |
| FRN001C1E-2U | |
| FRNF12C1E-7U | |
| FRNF25C1E-7U | |
| FRNF50C1E-7U | |
| FRNF12C1S-6U | |
| FRNF25C1S-6U | |
| FRNF50C1S-6U | |
| FRN001C1S-6U | |
| RMA-C1-2.2 | FRN002C1S-2U** |
| | FRN003C1S-2U** |
| | FRNF50C1S-4U** |
| | FRN001C1S-4U** |
| | FRN002C1S-4U** |
| | FRN003C1S-4U** |
| RMA-C1-3.7 | FRN002C1S-7U |
| | FRNF50C1E-4U |
| | FRN001C1E-4U |
| | FRN001C1E-7U |
| | FRN005C1S-2U** |
| | FRN005C1S-4U** |
| | FRN003C1S-7U |
| | FRN002C1E-2U |
| | FRN003C1E-2U |
| | FRN005C1E-2U |
| | FRN002C1E-4U |
| | FRN003C1E-4U |
| FRN005C1E-4U | |
| FRN002C1E-7U | |
| FRN003C1E-7U | |

■ Mounting adaptor (MA-C1-□□□)

This attachment enables mounting of the FRENIC-Mini as is, using the mounting holes of the existing inverters (FVR-E11S: 1HP or less, and 5HP units). (This attachment is not necessary in the case of the FVR-E11S-2/4 2HP, 3HP and FVR-E11S-7 1HP, 2HP units.)

| Option type | Applicable Inverter type | |
|-------------|--------------------------|----------------|
| | FRENIC-Mini | FVR-E11S |
| MA-C1-0.75 | FRNF12C1S-2U** | FVR0.1E11S-2 |
| | FRNF25C1S-2U** | FVR0.2E11S-2 |
| | FRNF50C1S-2U** | FVR0.4E11S-2 |
| | FRN001C1S-2U** | FVR0.75E11S-2 |
| | FRNF12C1S-7U | FVR0.1E11S-7EN |
| | FRNF25C1S-7U | FVR0.2E11S-7EN |
| | FRNF50C1S-7U | FVR0.4E11S-7EN |
| | FRN001C1S-7U | |
| | FRNF12C1E-2U | FVR0.1E11S-2 |
| | FRNF25C1E-2U | FVR0.2E11S-2 |
| MA-C1-3.7 | FRNF50C1E-2U | FVR0.4E11S-2 |
| | FRN001C1E-2U | FVR0.75E11S-2 |
| | FRNF12C1E-7U | FVR0.1E11S-7EN |
| | FRNF25C1E-7U | FVR0.2E11S-7EN |
| | FRNF50C1E-7U | FVR0.4E11S-7EN |
| | FRN005C1S-2U** | FVR3.7E11S-2 |
| | FRN005C1S-4U** | FVR3.7E11S-4EN |
| | FRN003C1S-7U | FVR2.2E11S-7EN |

■ NEMA1 kit (NEMA1-□□□C1-□)

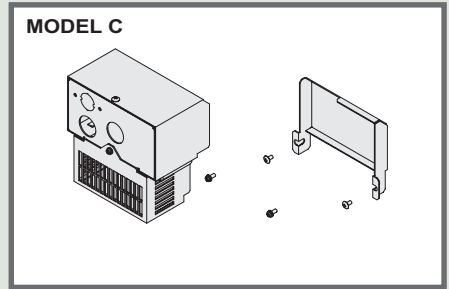
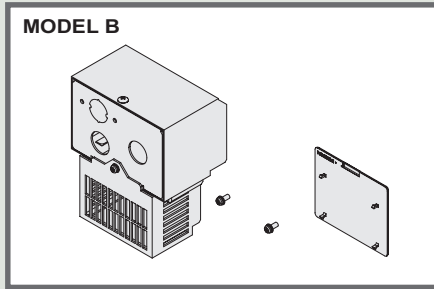
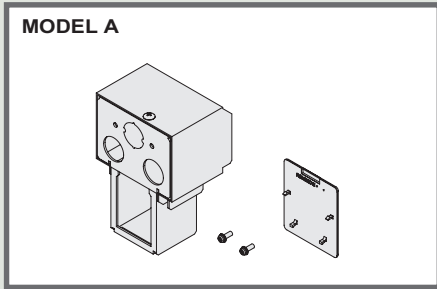

NEMA1 kit, when fitted to the FRENIC-Mini series, protects the inverter body with the structure that conforms to the NEMA1 standard (approved as UL TYPE1).

| Power supply voltage | Applicable Inverter type | Option type | MODEL |
|----------------------|--------------------------|----------------|-------|
| Three-phase 230V | FRNF12C1S-2U** | NEMA1-0.2C1-2 | A |
| | FRNF25C1S-2U** | NEMA1-0.4C1-2 | |
| | FRNF50C1S-2U** | NEMA1-0.75C1-2 | |
| | FRN001C1S-2U** | NEMA1-2.2C1-2 | B |
| | FRN002C1S-2U** | NEMA1-3.7C1-2 | C |
| Three-phase 460V | FRNF50C1S-4U** | NEMA1-0.4C1-4 | A |
| | FRN001C1S-4U** | NEMA1-0.75C1-4 | B |
| | FRN002C1S-4U** | NEMA1-2.2C1-2 | |
| | FRN003C1S-4U** | NEMA1-3.7C1-2 | C |
| Single-phase 230V | FRNF12C1S-7U | NEMA1-0.2C1-2 | A |
| | FRNF25C1S-7U | NEMA1-0.4C1-2 | |
| | FRNF50C1S-7U | NEMA1-0.75C1-7 | B |
| | FRN001C1S-7U | NEMA1-1.5C1-7 | |
| | FRN002C1S-7U | NEMA1-3.7C1-2 | |
| Single-phase 115V | FRNF12C1S-6U | NEMA1-0.2C1-6 | A |
| | FRNF25C1S-6U | NEMA1-0.4C1-6 | |
| | FRNF50C1S-6U | NEMA1-0.75C1-6 | |
| | FRN001C1S-6U | NEMA1-0.75C1-6 | |

Note) For the inverter type FRNF12C1S-2U**, the symbols ** are replaced with any of the following numeral codes:
 21 (Braking resistor built-in type), None (Standard type)
 The braking resistor built-in type is limited to the inverters for 2HP or larger.

● Warranty

The Compact Inverter FRENIC-Mini

To all our customers who purchase Fuji Electric FA Components & Systems' products:

Please take the following items into consideration when placing your order.

When requesting an estimate and placing your orders for the products included in these materials, please be aware that any items such as specifications which are not specifically mentioned in the contract, catalog, specifications or other materials will be as mentioned below.

In addition, the products included in these materials are limited in the use they are put to and the place where they can be used, etc., and may require periodic inspection. Please confirm these points with your sales representative or directly with this company.

Furthermore, regarding purchased products and delivered products, we request that you take adequate consideration of the necessity of rapid receiving inspections and of product management and maintenance even before receiving your products.

1. Free of Charge Warranty Period and Warranty Range

1-1 Free of charge warranty period

- The product warranty period is "1 year from the date of purchase" or 24 months from the manufacturing date imprinted on the name place, whichever date is earlier.
- However, in cases where the use environment, conditions of use, use frequency and times used, etc., have an effect on product life, this warranty period may not apply.
- Furthermore, the warranty period for parts restored by Fuji Electric's Service Department is "6 months from the date that repairs are completed."

1-2 Warranty range

- In the event that breakdown occurs during the product's warranty period which is the responsibility of Fuji Electric, Fuji Electric will replace or repair the part of the product that has broken down free of charge at the place where the product was purchased or where it was delivered. However, if the following cases are applicable, the terms of this warranty may not apply.
 - The breakdown was caused by inappropriate conditions, environment, handling or use methods, etc. which are not specified in the catalog, operation manual, specifications or other relevant documents.
 - The breakdown was caused by the product other than the purchased or delivered Fuji's product.
 - The breakdown was caused by the product other than Fuji's product, such as the customer's equipment or software design, etc.
 - Concerning the Fuji's programmable products, the breakdown was caused by a program other than a program supplied by this company, or the results from using such a program.
 - The breakdown was caused by modifications or repairs affected by a party other than Fuji Electric.
 - The breakdown was caused by improper maintenance or replacement using consumables, etc. specified in the operation manual or catalog, etc.
 - The breakdown was caused by a chemical or technical problem that was not foreseen when making practical application of the product at the time it was purchased or delivered.
 - The product was not used in the manner the product was originally intended to be used.
 - The breakdown was caused by a reason which is not this company's responsibility, such as lightning or other disaster.

- Furthermore, the warranty specified herein shall be limited to the purchased or delivered product alone.
- The upper limit for the warranty range shall be as specified in item (1) above and any damages (damage to or loss of machinery or equipment, or lost profits from the same, etc.) consequent to or resulting from breakdown of the purchased or delivered product shall be excluded from coverage by this warranty.

1-3. Trouble diagnosis

As a rule, the customer is requested to carry out a preliminary trouble diagnosis. However, at the customer's request, this company or its service network can perform the trouble diagnosis on a chargeable basis. In this case, the customer is asked to assume the burden for charges levied in accordance with this company's fee schedule.

2. Exclusion of Liability for Loss of Opportunity, etc.

Regardless of whether a breakdown occurs during or after the free of charge warranty period, this company shall not be liable for any loss of opportunity, loss of profits, or damages arising from special circumstances, secondary damages, accident compensation to another company, or damages to products other than this company's products, whether foreseen or not by this company, which this company is not be responsible for causing.

3. Repair Period after Production Stop, Spare Parts Supply Period (Holding Period)

Concerning models (products) which have gone out of production, this company will perform repairs for a period of 7 years after production stop, counting from the month and year when the production stop occurs. In addition, we will continue to supply the spare parts required for repairs for a period of 7 years, counting from the month and year when the production stop occurs. However, if it is estimated that the life cycle of certain electronic and other parts is short and it will be difficult to procure or produce those parts, there may be cases where it is difficult to provide repairs or supply spare parts even within this 7-year period. For details, please confirm at our company's business office or our service office.

4. Transfer Rights

In the case of standard products which do not include settings or adjustments in an application program, the products shall be transported to and transferred to the customer and this company shall not be responsible for local adjustments or trial operation.

5. Service Contents

The cost of purchased and delivered products does not include the cost of dispatching engineers or service costs. Depending on the request, these can be discussed separately.

6. Applicable Scope of Service

Above contents shall be assumed to apply to transactions and use of the country where you purchased the products. Consult the local supplier or Fuji for the detail separately.

MEMO



MEMO



NOTES

Application to standard motors

• Driving a 460V standard motor

When driving a 460V standard motor by an inverter with long cable lengths, damage may occur in the insulation of motor. Use the output circuit filter (OFL) if necessary after confirmation with the motor manufacturer. The use of Fuji Electric Motor does not require the output circuit filter because of its reinforced insulation.

• Torque characteristics and temperature rise

When the inverter is used to operate a standard motor, the temperature rises higher than during operation from a commercial power supply. The cooling effect decreases in the low-speed range, reducing the allowable output torque. (If a constant torque is required in the low-speed range, use a Fuji inverter motor or a motor equipped with a separately ventilating fan.)

• Vibration

Use of an inverter does not increase vibration of a standard motor, but when the motor is mounted to a machine, resonance may be caused by the natural frequencies including the natural frequency of the machine system.

* We recommend that you use a rubber coupling or anti-vibration rubber.

* We also recommend that you use the inverter jump frequency control function to avoid resonance point in the motor operation.

Note that operation of a 2-pole motor at 60Hz or over may cause abnormal vibration.

• Noise

When an inverter drives a standard motor, the motor noise level increases compared with driven by commercial power. To reduce noise, set the inverter carrier frequency at a high level. High-speed operation at 60Hz or over can result in more noise.

Application to special motors

• Explosion-proof motors

When driving an explosion-proof motor with an inverter, use a combination of a motor and an inverter that has been approved in advance. Such approved products are available in our special product series. Contact Fuji for details.

• Submersible motors and pumps

These motors have a larger rated current than standard motors. Select the inverter capacity so that these motors can run within the inverter rated current. These motors differ from standard motors in thermal characteristics.

Set a small value according to the thermal time constant of motor for setting electronic thermal relay function.

• Brake motors

For the motors with parallel-connected brakes, connect the brake power cable to the inverter's input side (primary circuit). If the brake power is connected to the output side (secondary circuit), the power may not be supplied to the brake, resulting in non-actuation of the brake. Do not use inverters for driving motors equipped with series-connected brakes.

• Geared motors

When the power transmission mechanism uses an

oil-lubricated gearbox or speed changer/reducer, continuous motor operation at low speed may cause poor lubrication.

• Synchronous motors

Synchronous motors cannot be driven by FRENIC-Mini inverter.

• Single-phase motors

Single-phase motors are not suitable for inverter-driven variable speed operation. Use three-phase motors.

* Even if a single-phase power supply is available, use a three-phase motor, because the inverter provides three-phase output.

Combination with peripheral device

• Installation location

Use the inverter in an ambient temperature range between -10 to 50°C (14 to 122°F).

The inverter and braking resistor surfaces become hot under certain operating conditions. Install an inverter on non-flammable material.

• Installing a circuit breaker

To protect the circuit from overcurrent, install a recommended molded-case circuit breaker (MCCB) or a ground-fault circuit interrupter (GFCI) (equipped with overcurrent protection function) on the inverter's input side (primary circuit). Ensure that the circuit breaker capacity does not exceed the recommended value.

• Magnetic contactor on the output side (secondary circuit)

When a magnetic contactor is installed on the inverter's output side (secondary circuit) for such a purpose as switching the power to the commercial power supply, ensure that both inverter and motor are stopped before switching. Remove the surge suppressor integrated with the magnetic contactor.

• Magnetic contactor on the input side (primary circuit)

Avoid frequent open/close (more than once an hour) of the circuit using the magnetic contactor on the input side (primary circuit). It may cause malfunction of the inverter. If frequent starts and stops are required, use signals to the control terminals FWD or REV.

• Protecting the motor

When you drive a motor with an inverter, the motor can be protected with an electronic thermal relay function of the inverter. In addition to the operation level, set the motor type (standard motor, inverter motor). For high-speed motors or water-cooled motors, set a small value in the thermal time constant to protect the motor in combination with the "cooling system OFF" signal. When driving several motors with an inverter, connect a thermal relay to each motor and turn on the inverter's electronic thermal relay function. If you connect the motor thermal relay to the motor with a long cable, high-frequency current may flow into the wiring stray capacitance. This may cause the relay to trip at a current lower than the set value for the thermal relay. If this happens, lower the carrier frequency or use the output circuit filter (OFL).

• Power-factor correcting capacitor

Do not mount the power-factor correcting capacitor in the inverter primary circuit. (Use the DC reactor to improve the inverter power factor.) Do not use the power-factor correcting capacitor in the inverter secondary circuit. Overcurrent trip will occur,

disabling motor operation.

• Reducing noise

Use of filter and shielded wires are typical measures against noise that meets EMC Directives. For details, refer to the operation procedure manual.

• Measures against surge current

If OV trip occurs while the inverter is stopped or operated under a light load, it is assumed that the surge current is generated by open/close of the phase-advancing capacitor in the power system.

* Connect a DC reactor to the inverter.

• Megger test

When checking insulation resistance of the inverter, use a 500V megger and follow the instructions described in the instruction manual.

Wiring

• Control circuit wiring length

When using remote control, limit the wiring length between the inverter and operator box to 65.6ft (20m) or less and use twisted shielded cable.

• Wiring length between inverter and motor

If long wiring is used between the inverter and the motor, the inverter will overheat or trip because of overcurrent (under the influence of high-frequency current flowing into the stray capacitance) in the wires connected to the phases. Ensure that the wiring is shorter than 164ft (50m) for models 5HP or smaller, shorter than 328ft (100m) for 7.5HP or larger. If these lengths must be exceeded, lower the carrier frequency or mount an output circuit filter (OFL).

When wiring is longer than 164ft (50m), and Dynamic torque-vector control is selected, execute off-line tuning.

• Wiring size

Select a cable with a sufficient capacity by referring to the current value or recommended wire size.

• Grounding

Securely ground the inverter using the grounding terminal.

Selecting inverter capacity

• Driving standard motor

Select an inverter from the capacity range of nominal applied motors shown in the inverter standard specifications table. When large starting torque is required or acceleration or deceleration is required in a short time, select an inverter with a capacity one size greater than the standard.

• Driving special motor

Select an inverter that meets the following condition: Inverter rated current > Motor rated current

Transportation, storage

When transporting or storing inverters, select the procedures and places that meet the environmental conditions given in the inverter specifications. Ensure that the above environmental conditions are met also when transporting an inverter mounted to a machine.

Fuji Electric FA Components & Systems Co., Ltd.
Fuji Electric Corp. of America

<http://www.fujielectric.com>



Printed on 100% recycled paper