

# Standard Products Catalog

AC Induction • Permanent Magnet DC • Brushless DC  
Gearmotors | Motors | Controls | Accessories



**BODINE**<sup>®</sup>  
**ELECTRIC**  
**COMPANY**

[bodine-electric.com](http://bodine-electric.com)

# For 2D/3D CAD drawings and distributor locations, go to [www.bodine-electric.com](http://www.bodine-electric.com)

Our website features the latest product specifications, technical documents, connection diagrams and instruction manuals. Dimension drawings and 3D models can be imported from the website directly into most CAD software programs. You will also find information about Bodine's newest products, our distributor locator, and helpful Tech Tools designed to answer the most commonly asked motion control questions.

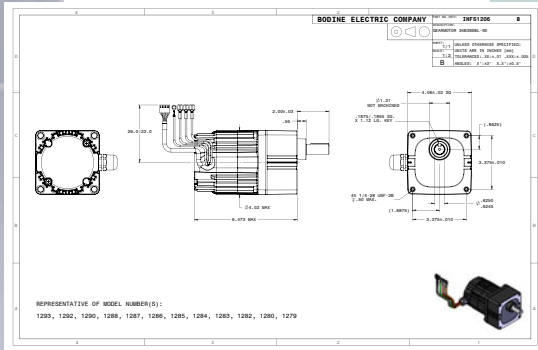

## UL/CSA Safety Compliance

Products are marked cURus or UR/CSA, and most products meet CE. All products are also RoHS



compliant. Motors and gearmotors

conform to UL standard 1004 and CSA standard C22.2 No. 100. They are documented in UL file number E47177 and CSA file number LR2797.

Electronic controls conform to UL standard 508 and CSA standard C22.2 No. 14. They are documented in UL file number E44529 and CSA file number LR26397.

## Motor Options

For the comparative advantages of AC motors and gearmotors, see page 21.

### Variable speed

#### Pacesetter AC motors

- Voltage ratings are 230 VAC, 60 Hz (3-phase) or 230/460 VAC, 60 Hz (3-phase)

#### Fixed-speed AC motors

- Voltage ratings are 115 VAC, 60 Hz (single-phase) or 230 VAC, 60 Hz (3-phase)
- Metric voltage ratings are 230 VAC, 50 Hz (1- or 3-phase)

#### Permanent Magnet DC motors

- Voltage ratings are 12/24 VDC, 24 VDC, 90/130 VDC or 130 VDC
- Metric voltage rating is 180 VDC
- Compatible with 90 V controls (90/130 VDC and 130 VDC only)

#### Brushless DC (ECM) motors

- Voltage ratings are 24 or 130 VDC

	Variable Speed Pacesetter Inverter Duty AC				Fixed-Speed AC				Permanent Magnet DC			Brushless DC		INTEGRA BLDC		
	30R	34R	42R	48R	K-2	30R	34R	42R	48R	24A	33A	42A	22B	34B	22B	34B
<b>Power (HP)</b>	1/25-1/17	1/8-1/4	3/8	1/3-3/4	1/1600- 1/200	1/40-1/30	1/15-1/5	1/12-1/4	1/5-1/2	1/50-1/7	1/16-1/3	1/4-1/2	1/16-1/5	1/5-3/8	1/16-1/8	1/4
<b>Torque (oz-in.)</b>	24-35	70-148	222	185-445	0.35-3.2	10-20	38-119	48-148	112-296	8-24	34-134	101-180	20-50	33-151	25-50	100
<b>Rated Speed (rpm)</b>	1700	1700, 1800	1700	1700, 1800	1200, 1550, 1800, 3600	1700, 1800, 3400	1700, 1800, 3400	1700, 3450	1700, 1800	2500, 11,500	2500	2500	2500, 10,000	2500, 10,000	2500	2500

© Copyright 2011. Catalog data subject to change without notice. All rights reserved. Printed in the U.S.A.

# Table of Contents

## Gearmotors

TORQUE	GEARHEAD	SPECIFICATIONS	DIMENSIONS
<b>Parallel Shaft</b>			
up to 120 oz-in.	Type <b>A/T (K-2)</b>	4	37
up to 40 lb-in.	Type <b>D</b>	5	36
up to 120 lb-in.	Type <b>Z</b>	6	36
up to 210 lb-in.	Type <b>WX</b>	7	36
up to 350 lb-in.	Type <b>E/F</b>	8	36
up to 1,000 lb-in.	Type <b>HG</b>	10	37
up to 1,000 lb-in.	Type <b>CG</b>	11	37
<b>Right Angle</b>			
up to 37 lb-in.	Type <b>3N/3F</b>	12	38
up to 77 lb-in.	Type <b>5R/5L</b>	13	38
up to 121 lb-in.	Type <b>5N</b>	14	39
up to 121 lb-in.	Type <b>5F</b>	15	39
up to 148 lb-in.	Type <b>3RD</b>	16	39
up to 296 lb-in.	Type <b>5H</b>	16	39
up to 380 lb-in.	Type <b>GB</b>	17	39
	Hollow Shaft		40



## Motors Without Gearing

MOTOR TYPE	POWER	SPECIFICATIONS	DIMENSIONS
Torque Motors	from 3.5 to 68 oz-in.	18	42
<b>Variable Speed—AC Pacesetter</b>			
Inverter Duty	from 1/25 to 3/4 HP	19	42
Fixed Speed—AC Induction	up to 1/2 HP	20	42
Permanent Magnet DC	up to 1/2 HP	22	42
Brushless DC	up to 1/2 HP	23	42
Direct Drive Brushless DC e-TORQ	up to 3.5 HP	23	43



## Motor Speed Controls

Pacesetter AC Inverters (for 230VAC Motors)	24	43
DC Motor Speed Controls (for 90/130V Motors)	25	43
Brushless DC Controls (for 24V and 130V Motors)	28	43



**2 Year**  
system warranty

## Accessories

## Reference Drawings and Dimensions

Purchase a Bodine gearmotor and speed control together and get our extended 2-year system warranty.

## Metric Motors and Gearmotors

<b>Metric Parallel Shaft</b>			
up to 0.67 Nm	Type <b>A/T (K-2)</b>	29	
up to 11.3 Nm	Type <b>D</b>	29	
up to 11.3 Nm	Type <b>Z</b>	30	
up to 19.8 Nm	Type <b>W</b>	30	
up to 35.0 Nm	Type <b>E/F</b>	31	
<b>Metric Right Angle</b>			
up to 16.7 Nm	Type <b>3F</b>	31	
up to 10.5 Nm	Type <b>5N/5F</b>	32	
up to 14.2 Nm	Type <b>5H</b>	32	
up to 43.0 Nm	Type <b>GB</b>	33	
<b>Metric Motors without Gearing</b>			
up to 140 Watts	Fixed Speed—AC Induction	33	
up to 112 Watts	Permanent Magnet DC	33	



### Reference

Hollow Shaft Gearmotor Benefits	17
Safe Operating Torque and Speed Area	19
Common Abbreviations	20
Comparative Advantages of AC Motors and Gearmotors	21
Speed Regulation of Permanent Magnet DC Motors	22

Most products are marked as RoHS COMPLIANT



# Gearmotors

Bodine Electric Company offers over one thousand standard gearmotors ranging from 1/2,000 to 3/4 HP (0.4 to 560 Watts), and e-TORO™ motors up to 3.5 HP (2,600 Watts). Our standard product line includes AC fixed speed and variable speed products, as well as an extensive selection of permanent magnet DC, and brushless DC gearmotors, motors and controls. We offer parallel shaft, right angle, and hollow shaft gearmotors, with torque ratings from 1 to 1,000 lb-in. (0.1-113 Nm).



## Parallel Shaft Gearmotors

A/T

Parallel Shaft Gearmotors | up to 120 oz-in.

- Totally enclosed, non-ventilated IP-20 rating
- Permanently lubricated, noise tested ball bearings
- Three-wire winding simplifies reversing
- Impedance protected to prevent current overload (gearmotor should not be stalled when powered up)
- Capacitor is included with gearmotor
- See page 37 for reference dimensions

### Fixed Speed – AC Gearmotors

Speed (rpm) (oz-in.)	Rated Torque (oz-in.)	Motor HP	V	Hz	Ph	Amps	Gear Ratio	Radial Load (oz.)	Capacitor (µF/VAC)	Product Type	Model Number
<b>Permanent Split Capacitor Normal Slip, Non-synchronous</b>										<b>CAPACITOR IS INCLUDED</b>	
0.9	120	1/700	115	60	1	0.07	1800	20	0.9/250	KCI-22T5	N0727
1.9	100	1/700				0.07	900		0.9/250	KCI-22T5	0726
5.6	95	1/700				0.07	300		0.9/250	KCI-22T4	0724
9	95	1/700				0.07	180		0.9/250	KCI-22T4	0723
13	95	1/450				0.083	120		1.0/250	KCI-23T4	0722
22	95	1/300				0.11	72		1.3/250	KCI-24T4	0733
26	80	1/300				0.11	60		1.3/250	KCI-24T3	0732
52	34	1/450				0.083	30		1.0/250	KCI-23A2	0719
52	59	1/300				0.11	30		1.3/250	KCI-24A2	0731
86	21	1/450				0.083	18		1.0/250	KCI-23A2	0718
86	35	1/300				0.11	18		1.3/250	KCI-24A2	0730
130	24	1/300				0.11	12		1.3/250	KCI-24A2	0729
260	12	1/300				0.11	6		1.3/250	KCI-24A2	0728
<b>Permanent Split Capacitor High Slip, Non-synchronous</b>										<b>CAPACITOR IS INCLUDED</b>	
0.9	120	1/1000	115	60	1	0.072	1800	20	0.9/250	KCI-22T5	N0746
2.3	95	1/1000				0.072	600		0.9/250	KCI-22T5	0744
4.9	95	1/1000				0.072	300		0.9/250	KCI-22T4	0743
10	88	1/800				0.083	120		1.0/250	KCI-23T4	0741
20	80	1/450				0.1	60		1.2/250	KCI-24T3	0750
40	44	1/450				0.1	30		1.2/250	KCI-24A2	0749
67	16	1/800				0.083	18		1.0/250	KCI-23A2	0737
67	27	1/450				0.1	18		1.2/250	KCI-24A2	0748
200	8.9	1/450				0.1	6		1.2/250	KCI-24A2	0747
<b>Permanent Split Capacitor, Synchronous</b>										<b>CAPACITOR IS INCLUDED</b>	
1	120	1/2000	115	60	1	0.069	1800	20	0.9/250	KYC-22T5	N0767
2	100	1/2000				0.069	900		0.9/250	KYC-22T5	N0766
3	88	1/2000				0.069	600		0.9/250	KYC-22T5	0765
10	72	1/900				0.093	180		1.3/250	KYC-24T4	0776
15	20	1/2000				0.069	120		.09/250	KYC-22T4	N0762
15	48	1/900				0.093	120		1.3/250	KYC-24T4	N0775
25	29	1/900				0.093	72		1.3/250	KYC-24T4	0774
60	15	1/900				0.093	30		1.3/250	KYC-24A2	0772
100	8.9	1/900				0.093	18		1.3/250	KYC-24A2	0771



- Unvented gearhousing for universal horizontal mounting
- Helical primary gear for quietness and hardened steel spur gearing
- on subsequent stages for high output torque and long life
- See page 24 for controls
- Capacitors and accessories on page 34
- See page 36 for reference dimensions

**Variable Speed—Pacesetter Inverter Duty AC Gearmotors**

Fixed Speed Rating					Variable Speed (SOA) Ratings <sup>1</sup>					Product Type	(230V) Model Number
Speed (rpm)	Torque (lb-in.)	Motor HP	A	Gear Ratio	Speed Range (rpm)	Frequency Range (Hz)	Torque Type	Torque @ 10 Hz (lb-in.)	Torque @ 60 Hz (lb-in.)		
<b>Three-Phase, Inverter Duty, Non-synchronous (TENV)</b>											
9	40	1/25	0.38	180	1.2-11.65	10-90	constant	40	40	40	30R2BEPP-D4 2210
19	40	1/25	0.38	90	2.5-23			40	40	40	30R2BEPP-D4 N2212
28	40	1/25	0.38	60	3.7-35			40	40	40	30R2BEPP-D3 N2214
142	19	1/17	0.48	12	19-175			19	19	19	30R4BEPP-D3 2216



Type 30R-D Pacesetter

**Fixed Speed—AC Gearmotors**

Speed (rpm)	Rated Torque (lb-in.)	Motor HP	V	Hz	Ph	Amps	Gear Ratio	Radial Load (lbs.)	Capacitor (µF/VAC)	Product Type	Model Number
<b>Permanent Split Capacitor, Non-synchronous</b>											
3.8	40	1/50	115	60	1	0.33	450	65	4.0/250	30R1BECI-D5	5463
9.4	40	1/50				0.33	180		4.0/250	30R1BECI-D4	5462
19	40	1/50				0.33	90		4.0/250	30R1BECI-D4	5461
28	40	1/30				0.45	60		5.0/250	30R2BECI-D3	5474
57	27	1/30				0.45	30		5.0/250	30R2BECI-D3	5473
94	16	1/30				0.45	18		5.0/250	30R2BECI-D3	5472
140	11	1/30				0.45	12		5.0/250	30R2BECI-D3	5471
285	5	1/30				0.45	6		5.0/250	30R2BECI-D3	5470



Type 30R-D

**Permanent Magnet DC Gearmotors**

Speed (rpm)	Rated Torque (lb-in.)	Rated Current (Amps)		Peak Torque (lb-in.)	Motor HP	Gear Ratio	Radial Load (lbs.)	Product Type <sup>2</sup>	Accy Shaft	No Accy Shaft	Accy Shaft	No Accy Shaft
		24V	130V						24V	130V		
5.6	40	1.8	0.30	55	1/29	450	24A2BEPM-D5	N4999	N4799	N4499	0199	
8.3	40	1.8	0.30	55	1/29	300	24A2BEPM-D5	N4998	N4798	N4498	0198	
14	40	1.8	0.30	55	1/29	180	24A2BEPM-D4	N4997	N4797	N4497	0197	
28	40	1.8	0.30	55	1/29	90	24A2BEPM-D4	N4996	N4796	N4496	0196	
42	40	2.6	0.48	55	1/17	60	24A4BEPM-D3	—	4690	—	0190	
42	36	1.8	0.30	55	1/29	60	24A2BEPM-D3	N4995	N4795	N4495	0195	
83	29	2.6	0.48	33	1/17	30	24A4BEPM-D3	—	—	—	0189	
83	18	1.8	0.30	33	1/29	30	24A2BEPM-D3	N4994	N4794	N4494	0194	
139	17	2.6	0.48	20	1/17	18	24A4BEPM-D3	—	—	—	0188	
139	11	1.8	0.30	20	1/29	18	24A2BEPM-D3	N4993	N4793	N4493	0193	
208	12	2.6	0.48	13	1/17	12	24A4BEPM-D3	—	—	—	0187	
208	7.1	1.8	0.30	13	1/29	12	24A2BEPM-D3	N4992	N4792	N4492	0192	
417	5.4	2.6	0.48	6.2	1/17	6	24A4BEPM-D3	—	—	—	0186	
417	3.3	1.8	0.30	6.2	1/29	6	24A2BEPM-D3	N4991	N4791	N4491	0191	



Type 24A-D

**Brushless DC Gearmotors**

Speed (rpm)	Rated Torque (lb-in.)	Rated Current (A)		Peak Torque (lb-in.)	Motor HP	Gear Ratio	Radial Load (lbs.)	Product Type	Accy Shaft	No Accy Shaft	Accy Shaft	No Accy Shaft
		24V	130V						24V	130V		
14	40	3.3	0.53	55	1/16	180	60	22B2BEBL-D4	N3636	N3536	N3433	3333
28	40			55		90		22B2BEBL-D4	N3635	N3535	N3431	N3331
42	40			55		60		22B2BEBL-D3	N3634	N3534	N3430	N3330
83	29			33		30		22B2BEBL-D3	3629	N3529	N3429	3329
139	17			20		18		22B2BEBL-D3	N3628	N3528	N3428	N3328
208	12			13		12		22B2BEBL-D3	N3627	N3527	N3427	3327
417	5.8			6.2		6		22B2BEBL-D3	N3626	N3526	N3426	3326



Type 22B-D

**INTEGRAmotor BLDC Gearmotors**

Motor Output				Control Input			Product Type	Model Number	
Speed Range (rpm)		Torque (lb-in.)	Gear Ratio	HP	Volts (VDC)	Continuous Amps		Type SR	Type FV
Type SR	Type FV								
0.7-8	0.3-8	40	300	1/16	24	3.3	22B2BEBL/**-D5	N3837	N3737
1-14	0.4-14	40	180				22B2BEBL/**-D4	3836	N3736
2-28	0.8-28	40	90				22B2BEBL/**-D4	N3835	N3735
3-42	1.3-42	40	60				22B2BEBL/**-D3	N3834	N3734
7-83	2.5-83	29	30				22B2BEBL/**-D3	3829	N3729
11-139	4.2-139	17	18				22B2BEBL/**-D3	N3828	N3728
17-208	6.3-208	12	12				22B2BEBL/**-D3	3827	N3727
33-417	13-417	5.8	6				22B2BEBL/**-D3	3826	N3726



Type 22B/SR-D and 22B/FV-D INTEGRAmotor

<sup>1</sup> SOA: Contact the factory for detailed speed/torque information (Safe Operating Area). See page 19.

<sup>3</sup> Type FV INTEGRAmotors require a PWM signal from a motion controller or PLC to operate.

"N" model numbers require lead time and minimum quantities.

<sup>2</sup> The fifth character of the product type changes from "B" to "F" for accessory ready models.

\*\* INTEGRAmotor can be ordered with either analog (/SR) or digital (/FV) interface option.

- Unvented gearhousing for universal horizontal mounting
- Permanently lubricated with high-performance lubricant
- Helical primary gear for quietness and hardened steel spur gearing on subsequent stages for high output torque and long life
- Models with accessory shafts are ideal for mounting encoders or brakes
- See page 34 for capacitors and accessories
- See page 36 for reference dimensions

Variable Speed—Pacesetter Inverter Duty AC Gearmotors



Type 34R-Z Pacesetter

Fixed Speed Rating				Variable Speed (SOA) Ratings <sup>1</sup>							Product Type	(230V) Model Number
Speed (rpm)	Torque (lb-in.)	Motor HP	A	Gear Ratio	Speed Range (rpm)	Frequency Range (Hz)	Torque Type	Torque @ 10 Hz (lb-in.)	Torque @ 60 Hz (lb-in.)	Torque @ 90 Hz (lb-in.)		
<b>Three-Phase, Inverter Duty, Non-synchronous (TENV)</b>												
9	120	1/6	0.73	180	0.9-13	10-90	constant	120	120	120	34R6BEPP-Z4	2220
19	120			90	1.8-26			120	120	120	34R6BEPP-Z4	N2222
28	120			60	2.8-39			120	120	120	34R6BEPP-Z3	N2224
57	96			30	5.5-78			96	96	96	34R6BEPP-Z3	2226
94	39			18	16-43			39	39	39	34R6BEPP-Z2	N2227
283	21			6	28-391			21	21	21	34R6BEPP-Z2	N2228

Fixed Speed—AC Gearmotors



Type 34R-Z

Speed (rpm)	Rated Torque (lb-in.)	Motor HP	V	Hz	Ph	Amps	Gear Ratio	Radial Load (lbs.)	Capacitor (µF/VAC)	Product Type	Model Number
<b>Permanent Split Capacitor, Non-synchronous</b>											
<b>CAPACITOR IS REQUIRED</b>											
9.6	100	1/15	115	60	1	1.0	180	125	10.0/250	34R4BFCI-Z4	0449
19	100						90	125		34R4BFCI-Z4	0448
28	100						60	125		34R4BFCI-Z3	0455
57	57						30	125		34R4BFCI-Z3	0454
94	36						18	100		34R4BFCI-Z2	0453
142	24						12	100		34R4BFCI-Z2	0452
283	12	6	100	34R4BFCI-Z2	0451						

Permanent Magnet DC Gearmotors



Type 24A-Z

Speed (rpm)	Rated Torque (lb-in.)	Rated Current (Amps)		Peak Torque (lb-in.)	Motor HP	Gear Ratio	Radial Load (lbs.)	Product Type <sup>2</sup>	Accy Shaft	No Accy Shaft	Accy Shaft	No Accy Shaft
		24V	130V						24V	130V		
<b>24A-Z PMDC Gearmotor</b>												
14	100	2.6	0.48	115	1/17	180	125	24A4BEPM-Z4	N4963	4663	N4563	0163
28	92			115		90	125	24A4BEPM-Z4	N4962	N4662	N4562	0162
42	65			115		60	125	24A4BEPM-Z3	N4961	4661	N4561	0161
83	33			59		30	125	24A4BEPM-Z3	N4960	4660	N4560	0160
139	21			38		18	100	24A4BEPM-Z2	N4959	N4659	N4559	0159
208	14			25		12	100	24A4BEPM-Z2	N4958	N4658	N4558	0158
417	7	13	6	100	24A4BEPM-Z2	N4957	4657	N4557	N0157			
<b>33A-Z PMDC Gearmotor</b>												
42	95	3.7	0.74	115	1/12	60	125	33A3BEPM-Z3	N6969	N6669	N6569	6169
83	47			59		30	125	33A3BEPM-Z3	N6968	N6668	N6568	6168
139	31			38		18	100	33A3BEPM-Z2	N6967	N6667	N6567	6167
208	20			25		12	100	33A3BEPM-Z2	N6966	N6666	N6566	6166
417	10			13		6	100	33A3BEPM-Z2	N6965	N6665	N6565	6165



Type 33A-Z

Brushless DC Gearmotors



Type 22B-Z

Speed (rpm)	Rated Torque (lb-in.)	Rated Current (Amps)		Peak Torque (lb-in.)	Motor HP	Gear Ratio	Radial Load (lbs.)	Product Type <sup>2</sup>	Accy Shaft	No Accy Shaft	Accy Shaft	No Accy Shaft
		24V	130V						24V	130V		
14	100	—	0.72	115	1/11	180	110	22B3BEBL-Z4	—	—	N3463	3363
14	100	3.3	0.53	115	1/16	180	110	22B2BEBL-Z4	—	N3563	—	—
21	100	3.3	0.53	115	1/16	120	110	22B2BEBL-Z4	—	N3564	—	N3364
28	100	4.4	0.72	115	1/11	90	110	22B3BEBL-Z4	—	—	N3462	N3362
28	97	3.3	0.53	115	1/16	90	110	22B2BEBL-Z4	—	N3562	—	—
42	95	4.4	0.72	115	1/11	60	110	22B3BEBL-Z3	3661	N3561	N3461	N3361
83	52	4.4	0.72	59	1/11	30	125	22B3BEBL-Z3	N3660	N3560	N3460	N3360
139	31	4.4	0.72	38	1/11	18	125	22B3BEBL-Z2	N3659	N3559	N3459	N3359
208	20	4.4	0.72	25	1/11	12	120	22B3BEBL-Z2	N3658	N3558	N3458	3358
417	10	4.4	0.72	13	1/11	6	100	22B3BEBL-Z2	N3657	N3557	N3457	3357

<sup>1</sup> SOA: Contact the factory for detailed speed/torque information (Safe Operating Area). See page 19.

<sup>2</sup> The fifth character of the product type changes from "B" to "F" for accessory ready models.

<sup>3</sup> Type FV INTEGRAMotors require a PWM signal from a motion controller or PLC to operate.

\*\* INTEGRAMotor can be ordered with either analog (VSR) or digital (FV) interface option.

"N" model numbers require lead time and minimum quantities.

**INTEGRAmotor BLDC Gearmotors**

Motor Output				Control Input			Product Type	Model Number	
Speed Range (rpm)		Torque (lb-in.)	Gear Ratio	HP	Volts (VDC)	Continuous Amps		Type SR	Type FV
Type SR	Type FV							Analog Interface	Digital Interface <sup>3</sup>
0.7-8	0.3-8	100	300	1/16	24	3.3	22B2BEBL/**-Z4	N3864	N3764
1-14	0.4-14	100	180	1/16		3.3	22B2BEBL/**-Z4	3863	N3723
2-28	0.8-28	97	90	1/16		3.3	22B2BEBL/**-Z4	N3862	N3762
3-42	1.3-42	95	60	1/11		4.4	22B3BEBL/**-Z3	N3861	N3761
7-83	2.5-83	52	30	1/11		4.4	22B3BEBL/**-Z3	3860	N3760
11-139	4.2-139	31	18	1/11		4.4	22B3BEBL/**-Z2	N3859	N3759
17-208	6.3-208	20	12	1/11		4.4	22B3BEBL/**-Z2	N3858	N3758
33-417	13-417	10	6	1/11		4.4	22B3BEBL/**-Z2	3857	N3757



Type 22B/SR-Z and 22B/FV-Z INTEGRAmotor

**up to 210 lb-in. | Parallel Shaft Gearmotors**



- Up to 65% more torque than previous models
- Unvented gearhousing
- Selectively hardened steel helical gears
- Synthetic lubricant
- Models with accessory shafts are ideal for mounting encoders or brakes
- Adaptor plate, model 0995, allows for 3-hole mounting configuration. See page 34
- See page 34 for capacitors and accessories
- See page 36 for reference dimensions

**Fixed Speed – AC Gearmotors**

Speed (rpm)	Rated Torque (lb-in.)	Motor HP	V	Hz	Ph	Amps	Gear Ratio	Radial Load (lbs.)	Capacitor (µF/VAC)	Product Type	Model Number
<b>Permanent Split Capacitor, Non-synchronous, 3-Wire-Reversible (TEFC)</b>											
5	210	1/7	115	60	1	1.7	312	130	27.5/250	34R6BFCI-WX4	1034
10	200						172	130		34R6BFCI-WX4	1032
17	195						98	130		34R6BFCI-WX4	1029
26	195						66	130		34R6BFCI-WX3	1027
31	190						55	130		34R6BFCI-WX3	1025
39	157						44	130		34R6BFCI-WX3	1023
57	106						30	130		34R6BFCI-WX3	1021
83	77						20	65		34R6BFCI-WX2	1019
123	46						14	65		34R6BFCI-WX2	1016
181	31						9	65		34R6BFCI-WX2	1014
309	18						6	65		34R6BFCI-WX2	1012
447	9						4	65		34R6BFCI-WX2	1010



Type 34R-WX

**Permanent Magnet DC Gearmotors**

Speed (rpm)		Rated Torque (lb-in.)	Amps		HP		FF	Gear Ratio	Radial Load (lbs.)	Product Type <sup>2</sup>	Accy		No Accy	
12/24V	90/130V		12/24V	90/130V	12/24V	90/130V					90/130V	12/24V	90/130V	
2.9 / 8.0	5 / 8	205	10.2	1.3 / 1.7	1/11 / 1/4	1/8 / 1/4	1.4 / 1.0	312	130	33A5BEPM-WX4	1422	1222	1452	1072
5 / 15	10 / 15	200						172	130	33A5BEPM-WX4	1420	1220	1450	1070
9 / 26	17 / 26	185						98	130	33A5BEPM-WX4	1418	1218	1448	1068
14 / 38	26 / 38	190						66	130	33A5BEPM-WX3	1416	1216	1446	1066
16 / 46	31 / 46	185						55	130	33A5BEPM-WX3	1414	1214	1444	1064
21 / 57	39 / 57	157						44	130	33A5BEPM-WX3	1412	1212	1442	1062
30 / 84	57 / 84	106						30	130	33A5BEPM-WX3	1410	1210	1440	1060
44 / 123	83 / 123	77						20	65	33A5BEPM-WX2	1408	1208	1438	1058
65 / 181	123 / 181	46						14	65	33A5BEPM-WX2	1406	1206	1436	1056
96 / 266	181 / 266	31						9	65	33A5BEPM-WX2	1404	1204	1434	1054
164 / 455	309 / 455	18						6	65	33A5BEPM-WX2	1402	1202	1432	1052
237 / 658	447 / 658	9						4	65	33A5BEPM-WX2	1400	1200	1430	1050



Type 33A-WX

**Brushless DC Gearmotors**

Speed (rpm)	Rated Torque (lb-in.)	Rated Current (Amps)		Motor HP	Gear Ratio	Radial Load (lbs.)	Product Type <sup>2</sup>	Accy Shaft		No Accy Shaft	
		24V	130V					24V	130V		
8	205	9.0	1.4	1/5	312	130	34B3BEBL-WX4	1323	1293	1123	1093
15	200				172	130	34B3BEBL-WX4	1322	1292	1122	1092
26	185				98	140	34B3BEBL-WX4	1320	1290	1120	1090
38	190				66	140	34B3BEBL-WX3	1318	1288	1118	1088
46	185				55	130	34B3BEBL-WX3	1317	1287	1117	1087
57	157				44	130	34B3BEBL-WX3	1316	1286	1116	1086
84	106				30	160	34B3BEBL-WX3	1315	1285	1115	1085
123	77				20	60	34B3BEBL-WX2	1314	1284	1114	1084
181	46				14	65	34B3BEBL-WX2	1313	1283	1113	1083
266	31				9	80	34B3BEBL-WX2	1312	1282	1112	1082
455	18				6	90	34B3BEBL-WX2	1310	1280	1110	1080
658	9				4	65	34B3BEBL-WX2	1309	1279	1109	1079



Type 34B-WX



- *E-type only*: selectively hardened all steel helical gears for long life
- *F-type only*: hardened helical gearing for quietness and high output to size ratio
- Unvented gearhousing for universal horizontal mounting
- Models with accessory shafts are ideal for mounting encoders or brakes
- See page 34 for capacitors and accessories
- See page 36 for reference dimensions

**Variable Speed—Pacesetter Inverter Duty AC Gearmotors**



Type 34R-E Pacesetter



Type 42R-F Pacesetter

Fixed Speed Rating						Variable Speed (SOA) Ratings <sup>1</sup>						Product Type	230V Model No.	230/460V Model No.	
Speed (rpm)	Torque (lb-in.)	HP	(230V) Amps	(230/460V) Amps	Gear Ratio	Speed Range (rpm)	Frequency Range (Hz)	Torque Type	Torque @ 10 Hz (lb-in.)	Torque @ 60 Hz (lb-in.)	Torque @ 90 Hz (lb-in.)				
<b>34R-E Pacesetter Gearmotor</b>															
<b>Three-Phase, Inverter Duty, Non-synchronous (TEFC)</b>															
5.7	310	1/6	1.0	1.0/0.5	300	0.4-7.3	10-90	constant	310	310	310	34R4BFPP-E4	N2256	2856	
9.4	341					180		0.7-12	constant	341	341	341	34R4BFPP-E4	2250	2850
19	250					90		1.3-24	constant	250	250	250	34R4BFPP-E4	2251	2851
28	270					60		2.0-36	variable	250	270	270	34R4BFPP-E3	N2252	2852
57	135					30		4.0-73	variable	124	135	135	34R4BFPP-E3	2253	2853
170	45					10		12-218	variable	42	45	45	34R4BFPP-E2	N2254	2854
340	25	5	24-436	variable	22	25	25	34R4BFPP-E1	N2255	2855					
<b>42R-F Pacesetter Gearmotor</b>															
<b>Three-Phase, Inverter Duty, Non-synchronous (TEFC)</b>															
57	250	3/8	1.9	1.9/0.95	30	5.9-77	10-90	constant	250	250	250	42R6BFPP-F3	2260	2860	
85	167					20		8.8-115	constant	167	167	167	42R6BFPP-F3	2261	2861
113	173					15		12-153	variable	140	173	173	42R6BFPP-F2	N2262	2862
170	115					10		18-229	variable	92	115	115	42R6BFPP-F2	2262	2862
340	58					5		35-459	variable	48	58	58	42R6BFPP-F1	2263	2863

**Fixed Speed—AC Gearmotors**



Type 42R-E



Type 48R-F

Speed (rpm)	Rated Torque (lb-in.)	Motor HP	V	Hz	Ph	Amps	Gear Ratio	Radial Load (lbs.)	Capacitor (µF/VAC)	Product Type	Model Number						
<b>42R-E Fixed Speed AC Gearmotors</b>																	
<b>Permanent Split Capacitor, Non-synchronous</b>																	
<b>CAPACITOR IS REQUIRED</b>																	
5.7	310	1/12	115	60	1	1.2	300	200	7.5/370	42R3BFCSI-E4	0671						
9.4	341	1/12					180	200	7.5/370	42R3BFCSI-E4	0669						
14	290	1/12					120	200	7.5/370	42R3BFCSI-E4	0668						
28	270	1/6					60	200	15/370	42R5BFCSI-E3	0685						
57	135	1/6					30	300	15/370	42R5BFCSI-E3	0683						
85	90	1/6					20	300	15/370	42R5BFCSI-E3	0681						
115	68	1/6					15	300	15/370	42R5BFCSI-E2	N0682						
170	45	1/6					10	300	15/370	42R5BFCSI-E2	0680						
340	25	1/6					5	300	15/370	42R5BFCSI-E1	0679						
<b>Split Phase (with centrifugal switch), Non-synchronous</b>																	
5.7	310	1/12					115	60	1	2.4	300	200	—	42R3BFCSI-E4	0639		
9.4	341	1/12									180	200	—	42R3BFCSI-E4	0637		
14	277	1/12	120	200	—	42R3BFCSI-E4					0636						
19	208	1/12	90	200	—	42R3BFCSI-E4					0635						
28	270	1/6	60	200	—	42R5BFCSI-E3					0655						
42	180	1/6	40	200	—	42R5BFCSI-E3					0654						
57	135	1/6	30	300	—	42R5BFCSI-E3					0653						
85	90	1/6	20	300	—	42R5BFCSI-E3					0652						
115	68	1/6	15	300	—	42R5BFCSI-E2					0651						
170	45	1/6	10	300	—	42R5BFCSI-E2					0650						
340	25	1/6	5	300	—	42R5BFCSI-E1					0649						
<b>Three-phase, Non-synchronous</b>																	
28	270	1/4	230	60	3	1.3	60	200	—	42R5BFPP-E3	0667						
57	135						30	300	—	42R5BFPP-E3	0666						
170	45						10	300	—	42R5BFPP-E2	0665						
<b>48R-F Fixed Speed AC Gearmotor</b>																	
<b>Permanent Split Capacitor, Non-synchronous</b>																	
<b>CAPACITOR IS REQUIRED</b>																	
57	250	1/3	115/230	60	1	4.0/2.0	30	300	115V=20.0/370 230V=12.5/370	48R6BFCSI-F3	0694						
85	167						20			48R6BFCSI-F3	0693						
113	162						15			48R6BFCSI-F2	N0695						
170	108						10			48R6BFCSI-F2	0692						
340	56						5			48R6BFCSI-F1	0691						
<b>Split Phase (with centrifugal switch), Non-synchronous</b>																	
57	250	1/3	115/230	60	1	4.8/2.4	30	300	—	48R6BFCSI-F3	0664						
85	167						20		48R6BFCSI-F3	0663							
170	108						10		48R6BFCSI-F2	0662							
340	56						5		48R6BFCSI-F1	0661							
<b>Three-phase, Non-synchronous</b>																	
47/57	250						1/2		230/460	50/60	3	230V=2.0/1.7 460V=1.0/0.85	@50/60 Hz	300	—	48R6BFPP-F3	0643
70/85	167	20	48R6BFPP-F3	0642													
140/170	115	10	48R6BFPP-F2	0641													
280/340	58	5	48R6BFPP-F1	N0640													



**Permanent Magnet DC Gearmotors**

Speed (rpm)	Rated Torque (lb-in.)	Rated Current (Amps)		Peak Torque (lb-in.)	Motor HP	FF	Gear Ratio	Radial Load (lbs.)	Product Type <sup>2</sup>	Accy Shaft	No Accy Shaft	Accy Shaft	No Accy Shaft	
		24V	130V							24V		130V		
<b>42A-E/F Gearmotor</b>														
<b>24V or 130V Class F Temperature Rating</b>														
8.3	310	5.8	1.0	475	1/8			300	200	42A3BEPM-E4	N4975	N4675	N4575	4175
14	341	5.8	1.0	475	1/8			180	200	42A3BEPM-E4	N4974	N4674	N4574	4174
21	283	5.8	1.0	475	1/8			120	200	42A3BEPM-E4	N4973	N4673	N4573	4173
42	270	8.8	1.8	421	1/4			60	200	42A5BEPM-E3	N4985	4685	4585	4185
62	220	12	2.3	440	1/3			40	300	42A7BEPM-F3	N4984	N4684	N4584	4193
62	180	8.8	1.8	280	1/4			40	200	42A5BEPM-E3	N4976	N4676	N4576	4184
83	135	8.8	1.8	318	1/4			30	300	42A5BEPM-E3	N4983	N4683	4583	4183
125	145	—	2.3	440	1/3	1.0		20	300	42A7BEPM-F3	—	—	—	4192
125	90	8.8	1.8	212	1/4			20	300	42A5BEPM-E3	N4982	N4682	N4582	4182
165	109	—	2.3	144	1/3			15	300	42A7BEPM-F2	—	—	—	4191
165	68	8.8	1.8	160	1/4			15	300	42A5BEPM-E2	N4981	4681	N4581	4181
250	72	12	2.3	144	1/3			10	300	42A7BEPM-F2	N4978	N4678	N4578	4190
250	45	8.8	1.8	106	1/4			10	300	42A5BEPM-E2	N4980	N4680	4580	4180
500	25	8.8	1.8	55	1/4			5	300	42A5BEPM-E1	N4979	N4679	N4579	4179



Type 42A-E/F

<b>33A-E/F Gearmotor</b>														
<b>24V, Class F Temperature Rating</b>														
21	280	5.5	—	475	1/8			120	195	33A3BEPM-E4	N6973	N6673	—	—
42	270	9.2	—	421	1/4			60	240	33A5BEPM-E3	N6985	6685	—	—
62	220	12	—	440	1/3			40	250	33A7BEPM-F3	N6984	6684	—	—
250	72	12	—	144	1/3	1.0		10	300	33A7BEPM-F2	N6978	N6678	—	—
250	45	9.2	—	106	1/4			10	300	33A5BEPM-E2	N6980	6680	—	—
500	37	12	—	74	1/3			5	60	33A7BEPM-F1	N6991	N6691	—	—
500	24	9.2	—	55	1/4			5	60	33A5BEPM-E1	N6979	N6679	—	—

<b>90 / 130V, Class F Temperature Rating</b>													<b>90/130V</b>	
5.8 / 8.3	310 / 310	—	.78 / 1.0	475	1/16 / 1/8			300	220	33A3BEPM-E4	—	—	—	6175
9.6 / 14	279 / 341	—	.78 / 1.0	475	1/16 / 1/8			180	200	33A3BEPM-E4	—	—	—	6174
14 / 21	198 / 280	—	.78 / 1.0	475	1/16 / 1/8			120	195	33A3BEPM-E4	—	—	N6573	6173
29 / 42	226 / 270	—	1.4 / 1.8	421	1/8 / 1/4			60	240	33A5BEPM-E3	—	—	6585	6185
43 / 62	205 / 220	—	1.8 / 2.4	440	1/6 / 1/3			40	250	33A7BEPM-F3	—	—	—	6193
43 / 62	151 / 180	—	1.4 / 1.8	280	1/8 / 1/4			40	250	33A5BEPM-E3	—	—	N6584	6184
58 / 83	113 / 135	—	1.4 / 1.8	318	1/8 / 1/4	1.4 / 1.0		30	300	33A5BEPM-E3	—	—	6583	6183
86 / 125	75 / 90	—	1.4 / 1.8	212	1/8 / 1/4			20	300	33A5BEPM-E3	—	—	—	6182
115 / 165	57 / 68	—	1.4 / 1.8	160	1/8 / 1/4			15	300	33A5BEPM-E2	—	—	—	6181
173 / 250	51 / 72	—	1.8 / 2.4	144	1/6 / 1/3			10	300	33A7BEPM-F2	—	—	N6578	6190
173 / 250	38 / 45	—	1.4 / 1.8	106	1/8 / 1/4			10	300	33A5BEPM-E2	—	—	6580	6180
345 / 500	26 / 37	—	1.8 / 2.4	74	1/6 / 1/3			5	60	33A7BEPM-F1	—	—	N6591	6191
345 / 500	19 / 24	—	1.4 / 1.8	55	1/8 / 1/4			5	60	33A5BEPM-E1	—	—	N6579	6179



Type 33A-E/F

**Brushless DC Gearmotors**

Speed (rpm)	Rated Torque (lb-in.)	Rated Current (Amps)		Peak Torque (lb-in.)	Motor HP	Gear Ratio	Radial Load (lbs.)	Product Type <sup>2</sup>	Accy Shaft	No Accy Shaft	Accy Shaft	No Accy Shaft
		24V	130V						24V		130V	
8.3	310	9.6	1.6	475	1/5	300	220	34B3BEBL-E4	—	N3575	—	N3375
14	341	9.6	1.6	475	1/5	180	200	34B3BEBL-E4	—	N3574	—	3374
21	350	9.6	1.6	475	1/5	120	195	34B3BEBL-E4	—	N3573	—	3373
42	270	12	2.0	421	1/4	60	240	34B4BEBL-E3	N3685	3585	N3485	3385
83	245	—	2.6	475	3/8	30	250	34B6BEBL-F3	—	—	—	N3372
83	135	12	2.0	318	1/4	30	300	34B4BEBL-E3	N3683	N3583	3483	3383
125	163	—	2.6	333	3/8	20	290	34B6BEBL-F3	—	—	—	N3371
125	90	12	2.0	220	1/4	20	300	34B4BEBL-E3	N3682	N3582	3482	3382
250	82	—	2.6	166	3/8	10	300	34B6BEBL-F2	—	—	N3470	N3370
250	45	12	2.0	106	1/4	10	300	34B4BEBL-E2	N3680	N3580	N3480	3380
500	42	—	2.6	86	3/8	5	60	34B6BEBL-F1	—	—	—	3369
500	25	12	2.0	55	1/4	5	60	34B4BEBL-E1	—	N3579	—	3379



Type 34B-E/F

**INTEGRAmotor BLDC Gearmotors**

Speed (rpm)	Rated Torque (lb-in.)	24V Rated Current (Amps)	Peak Torque (lb-in.)	Motor HP	Gear Ratio	Radial Load (lbs.)	Product Type	Model Number <sup>3</sup>
14	341	12	475	1/4	180	200	34B4FEBL/FV-F4	N3771
42	320		421		60	240	34B4FEBL/FV-F3	N3773
63	213		350		40	240	34B4FEBL/FV-F3	3774
83	160		318		30	300	34B4FEBL/FV-F3	N3775
125	107		220		20	300	34B4FEBL/FV-F3	N3776
250	53		106		10	300	34B4FEBL/FV-F2	N3778
500	28		55		5	60	34B4FEBL/FV-F1	N3779



Type 34B/FV-F INTEGRAmotor

<sup>1</sup> SOA: Contact the factory for detailed speed/torque information (Safe Operating Area). See page 19.

<sup>2</sup> The fifth character of the product type changes from "B" to "F" for accessory ready models.

<sup>3</sup> Type FV INTEGRAmotors require a PWM signal from a motion controller or PLC to operate.

"N" model numbers require lead time and minimum quantities.

- Unvented gearhousing
- Flexible mounting and high torque in a compact package
- Face-mount from drive shaft side
- Models with accessory shafts are ideal for mounting encoders or brakes
- See page 34 for capacitors and terminal boxes
- See page 37 for reference dimensions

**Variable Speed—Pacesetter Inverter Duty AC Gearmotors**



Type 42R-HG Pacesetter

Fixed Speed Rating					Variable Speed (SOA) Ratings <sup>1</sup>					Radial Load (lbs.)	Product Type	230V Model Number	
Speed (rpm)	Torque (lb-in.)	Motor HP	A	Gear Ratio	Speed Range (rpm)	Frequency Range (Hz)	Torque Type	Torque @ 10 Hz (lb-in.)	Torque @ 60 Hz (lb-in.)				Torque @ 90 Hz (lb-in.)
<b>Three -Phase, Inverter duty, Non-synchronous (TEFC)</b>													
16	1,000	3/8	1.9	108	2-21	10-90	variable	896	1,000	896	350	42R6BFPP-HG	2245
30	600			56	3-41			464	776	464			N2247
38	480			45	4-51			373	623	373			N2248
63	289			27	7-85			224	368	224			2249

**Fixed Speed—AC Gearmotors**



Type 42R-HG

Speed (rpm)	Rated Torque (lb-in.)	Motor HP	V	Hz	Ph	Amps	Gear Ratio	Radial Load (lbs.)	Capacitor (µF/VAC)	Product Type	Model Number
<b>Permanent Split Capacitor, Non-synchronous (TEFC)</b>											
<b>CAPACITOR IS REQUIRED</b>											
16	599	1/5	115	60	1	2.7	108	350	30.0/250	42R6BFCl-HG	N5255
30	310						56				5257
38	250						45				N5258
63	150						27				N5259

**Permanent Magnet DC Gearmotors**



Type 33A-HG

Speed (rpm)	Rated Torque (lb-in.)	Rated Current (Amps)		Motor HP	Gear Ratio	Radial Load (lbs.)	Product Type <sup>2</sup>	Accy Shaft	No Accy Shaft	Accy Shaft	No Accy Shaft
		24V	90/130V					24V		90/130V	
<b>24V Models With Class F Temperature Rating</b>											
23	680	12	—	1/3	108	350	33A7BEPm-HG	N6823	N6423	—	—
45	353				56			6845	N6445	—	—
56	284				45			N6856	6456	—	—
93	170				27			N6893	N6493	—	—
<b>90/130V Models With Class F Temperature Rating</b>											
16 / 23	481 / 680	—	1.8 / 2.4	1/6 / 1/3	108	350	33A7BEPm-HG	—	—	N6323	6023
31 / 45	249 / 353				56			—	6345	N6045	
38 / 56	200 / 284				45			—	N6356	N6056	
64 / 93	120 / 170				27			—	N6393	6093	

<sup>1</sup> SOA: Contact the factory for detailed speed/torque information (Safe Operating Area). See page 19.

<sup>2</sup> The fifth digit of the product type changes from "B" to "F" for accessory ready models.

"N" model numbers require lead time and minimum quantities.

- Unvented gearhousing for universal horizontal mounting
- Selectively hardened steel gears for quietness and hardened steel spur gearing on subsequent stages for high output torque and long life
- Extra heavy-duty bearings and seals
- Face or base mounting
- Oversize drive shaft
- Models with accessory shafts are ideal for mounting encoders or brakes
- See page 34 for accessories
- See page 37 for reference dimensions

Variable Speed—Pacesetter Inverter Duty AC Gearmotors

Fixed Speed Rating					Variable Speed (SOA) Ratings <sup>1</sup>						Radial Load (lbs.)	Product Type	230/460V Model Number
Speed (rpm)	Torque (lb-in.)	Motor HP	(230/460V) Amps	Gear Ratio	Speed Range (rpm)	Frequency Range (Hz)	Torque Type	Torque @ 10 Hz (lb-in.)	Torque @ 60 Hz (lb-in.)	Torque @ 90 Hz (lb-in.)			
28	1000	3/4	2.7/1.3	60	2.7-38	10-90	Constant	1,000	1,000	1,000	250	48R6BFPP-CG	9360
34	850			50	3.2-46			850	850	850			9350
47	650			36	4.4-63			650	650	650			9336
57	540			30	5.3-76			540	540	540			9330
85	360			20	8.0-114			360	360	360			9320

Three-Phase, Inverter duty, Non-synchronous (TEFC)



Type 48R-CG Pacesetter

Permanent Magnet DC Gearmotors

Speed (rpm)	Rated Torque (lb-in.)	Rated Current (Amps)	Motor HP	Gear Ratio	Radial Load (lbs.)	Product Type <sup>2</sup>	24V		130V	
							Accy Shaft	No Accy Shaft	Accy Shaft	No Accy Shaft
<b>24V Models With Class F Temperature Rating</b>										
38	660	18	7/16	60	250	42A7BEPM-CG	4886	4486	—	—
46	550			50			4885	4485	—	—
64	400			36			4884	4484	—	—
77	330			30			4883	4483	—	—
115	220			20			4882	4482	—	—
<b>130V Models with Class F Temperature Rating</b>										
42	580	3.3	7/16	60	250	42A7BEPM-CG	—	—	4786	4086
50	480			50			—	—	4785	4085
69	350			36			—	—	4784	4084
83	290			30			—	—	4783	4083
125	190			20			—	—	4782	4082



Type 42A-CG

<sup>1</sup> SOA: Contact the factory for detailed speed/torque information (Safe Operating Area). See page 19.

<sup>2</sup> The fifth digit of the product type changes from "B" to "F" for accessory ready models.



# Right Angle Gearmotors

**3N/3F**

Right Angle Gearmotors | up to 37 lb-in.

- Unvented gearhousing for universal horizontal mounting
- Permanently lubricated with high-performance lubricant
- Bronze gear for high shock load capability
- Hardened and ground worm for high strength and long life
- Models with accessory shafts are ideal for mounting encoders or brakes
- See page 34 for capacitors and accessories
- See pages 38 and 40 for reference dimensions

## Variable Speed—Pacesetter Inverter Duty AC Gearmotors



Type 30R-3N Pacesetter

Fixed Speed Rating				Variable Speed (SOA) Ratings <sup>1</sup>							Product Type	230V Model Number
Speed (rpm)	Torque (lb-in.)	Motor HP	A	Gear Ratio	Speed Range (rpm)	Frequency Range (Hz)	Torque Type	Torque @ 10 Hz (lb-in.)	Torque @ 60 Hz (lb-in.)	Torque @ 90 Hz (lb-in.)		
28	37	1/17	0.48	60	2.2-36	10-90	constant	37	37	37	30R4BEPP-3N	N2290
34	36			50	2.7-43		variable	33	37	37		N2292
43	37			40	3.3-54		constant	37	37	37		N2293
85	25			20	6.6-108		variable	24	36	36		2294
170	14			10	13-216		variable	16	28	22		N2296
340	8			5	27-431		variable	9	15	12		N2297

### Three-Phase, Inverter Duty, Non-synchronous Motor (TENV)

## Fixed Speed—AC Gearmotors



Type 34R-3F

Speed (rpm)	Rated Torque (lb-in.)	Motor HP	V	Hz	Ph	Amps	Gear Ratio	Radial Load (lbs.)	Capacitor (µF/VAC)	Product Type	Model Number
28	37	1/15	115	60	1	1.0	60	40	10.0/250	34R4BFCI-3F	0492
43	37						40	40			0491
57	30						30	40			0487
85	27						20	40			0490
113	20						15	5			0489
170	16						10	5			0488

### Permanent Split Capacitor, Non-synchronous

### CAPACITOR IS REQUIRED

## Permanent Magnet DC Gearmotors



Type 24A-3F (Mounting from base of gearhead)

Speed (rpm)	Rated Torque (lb-in.)	Rated Current (Amps)		Peak Torque (lb-in.)	Motor HP	FF	Gear Ratio	Radial Load (lbs.)	Product Type <sup>2</sup>	Accy Shaft		No Accy Shaft	
		24V	130V							24V	130V		
42	22	2.6	0.48	46	1/17	1.0	60	40	24A4BEPM-3F	N4899	N4699	N4099	0099
63	19			46			40	40		N4898	N4698	N4098	0098
125	16			32			20	5		N4896	N4696	N4096	0096
250	10			20			10	5		N4894	4694	N4094	0094
500	5.2			10			5	5		N4893	N4693	N4093	0093

### Mounting From Base Of Gearhead



Type 24A-3F (Mounting from base of motor)

Speed (rpm)	Rated Torque (lb-in.)	Rated Current (Amps)	Peak Torque (lb-in.)	Motor HP	FF	Gear Ratio	Radial Load (lbs.)	Product Type <sup>2</sup>	Accy Shaft	No Accy Shaft	Accy Shaft	No Accy Shaft
42	22	—	46	1/17	1.0	60	40	24A4BEPM-3F	—	—	—	N0089
63	19	—	46			40	40		—	—	—	0088
125	16	—	32			20	5		—	—	—	0087
250	10	—	20			10	5		—	—	—	0086
500	5.2	—	10			5	5		—	—	—	N0084

### Mounting From Base Of Motor



Type 24A-3F/H Hollow Shaft

Hollow Shaft													
24 V Models With Class F Temperature Rating													
250	14	3.7	—	20	1/13	—	10	60	24A4BEPM-3F/H	—	N7694	—	
500	6.8		—	10		—	5	70		N7893	—	—	—
90 V/130 V Models With Class F Temperature Rating													
29/42	35 / 37	0.56 / 0.81	—	46	1/23 / 1/11	1.4 / 1.0	60	100	24A4BEPM-3F/H	—	—	—	7099
43/63	29 / 37		—	46			40	90		—	—	—	7098
86/125	18 / 26		—	32			20	80		—	—	—	7096
173/250	10 / 16		—	20			10	70		—	—	—	7094
345/500	5.5 / 8.2		—	10			5	60		—	—	—	7093

## Brushless DC Gearmotors



Type 22B-3N

Speed (rpm)	Rated Torque (lb-in.)	Rated Current (Amps)		Peak Torque (lb-in.)	Motor HP	Gear Ratio	Radial Load (lbs.)	Product Type <sup>2</sup>	Accy Shaft		No Accy Shaft	
		24V	130V						24V	130V		
42	37	5.9	1.0	147	1/8	60	100	22B4BEPL-3N	N3665	3565	N3421	N3321
62	37			123		40	90		N3666	N3566	N3422	3322
125	35			74		20	80		3667	N3567	N3423	N3323
250	22			46		10	70		N3668	N3568	3424	N3324
500	11			23		5	60		N3669	N3569	N3425	3325

**INTEGRAMotor BLDC Gearmotors**

Motor Output				Control Input			Product Type <sup>2</sup>	Model Number	
Speed Range (rpm)		Torque (lb-in.)	Gear Ratio	Motor HP	Volts (VDC)	Continuous Amps		Type SR	Type FV
Type SR	Type FV							Analog Interface	Digital Interface <sup>3</sup>
3-42	1.3-42	37	60	1/8	24	5.9	22B4BEBL/**-3N	N3865	N3765
5-62	2-62	37	40					3866	N3766
10-125	4-125	35	20					N3867	N3767
20-250	7.5-250	22	10					3868	N3768
40-500	15-500	11	5					N3869	N3769



Type 22B/SR-3N  
INTEGRAMotor

**Hollow Shaft**

3-42	1.3-42	37	60	1/8	24	5.9	22B4BEBL/**-3F/H	N8865	N8765
5-62	2-62	37	40					N8866	N8766
10-125	4-125	35	20					N8867	N8767
20-250	7.5-250	22	10					N8868	N8768
40-500	15-500	11	5					N8869	N8769



Type 22B/SR-3F/H  
INTEGRAMotor  
Hollow Shaft

**up to 77 lb-in. | Right Angle Gearmotors**

**5R/5L**

- Unvented gearhousing for universal horizontal mounting
- Permanently lubricated with high-performance lubricant
- Bronze gear for high shock load capability
- Hardened and ground worm for high strength and long life
- See page 34 for capacitors and terminal boxes
- See page 38 for reference dimensions

**Fixed Speed—AC Gearmotors**

Speed (rpm)	Rated Torque (lb-in.)	Motor HP	V	Hz	Ph	Amps	Gear Ratio	Radial Load (lbs.)	Capacitor (μF/VAC)	Product Type	Model Number
<b>34R-5R Permanent Split Capacitor, Non-synchronous, Class B Temperature Rating (TEFC) CAPACITOR IS REQUIRED</b>											
28	33	1/15	115	60	1	1.0	60	50	10.0/250	34R4BFCL-5R	0469
43	49						40	50			0468
85	32						20	50			0466
170	18						10	30			0465
<b>42R-5L Permanent Split Capacitor, Non-synchronous, Class B Temperature Rating (TEFC) CAPACITOR IS REQUIRED</b>											
43	77	1/8	115	60	1	1.7	40	80	12.5/250	42R4BFCL-5L	0627
57	75						30	80			0626
85	54						20	80			0624
170	31						10	10			0623
<b>42R4-5L Split Phase, Non-synchronous, Class B Temperature Rating (TEFC)</b>											
43	77	1/8	115	60	1	3.0	40	80	—	42R4BFSL-5L	0620
57	75						30	80	—		0619
85	54						20	80	—		0618
170	31						10	10	—		0617



Type 34R-5R



Type 42R-5L

**Permanent Magnet DC Gearmotors**

Speed (rpm)	Rated Torque (lb-in.)	130V Rated Current (Amps)	Peak Torque (lb-in.)	Motor HP	FF	Gear Ratio	Radial Load (lbs.)	Product Type	Model Number
<b>33A-5R 130V Models With Class B Temperature Rating, Grease Lubrication</b>									
50	45	0.71	118	1/12	1.0	40	80	33A3BEPM-5R	6128
67	41		83			30	80		6127
100	29		44			20	80		6126
200	17		23			10	80		6125
<b>33A-5L 130V Models With Class F Temperature Rating, Oil Lubrication</b>									
50	77	1.4	179	1/6	1.0	40	80	33A5BEPM-5L	6119
67	75		169			30	80		6118
100	63		159			20	80		6117
200	37		91			10	80		6116
<b>42A-5L 130V Models With Class F Temperature Rating, Oil Lubrication</b>									
50	77	1.3	177	1/6	1.0	40	80	42A4BEPM-5L	4119
67	75		169			30	80		4118
100	63		159			20	80		4117
200	37		91			10	80		4116



Type 33A-5R



Type 42A-5L

<sup>1</sup> SOA: Contact the factory for detailed speed/torque information (Safe Operating Area). See page 19.  
<sup>2</sup> The fifth character of the product type changes from "B" to "F" for accessory ready models.  
<sup>3</sup> Type FV INTEGRAMotors require a PWM signal from a motion controller or PLC to operate.  
 \*\* INTEGRAMotor can be ordered with either analog (/SR) or digital (/FV) interface option.  
 "N" model numbers require lead time and minimum quantities.

- *Type 5N only:* Needle bearings on driveshaft for high radial load capacity and long life
- *Type 5L/H only:* Ball bearings for high radial load and long life
- Unvented gearhousing for universal horizontal mounting
- Bronze worm gear for high shock load capability
- Hardened and ground worm for strength and long life
- See page 34 for capacitors and terminal boxes
- See pages 39 and 40 for reference dimensions

**Variable Speed—Pacesetter Inverter Duty AC Gearmotors**



Type 42R-5N Pacesetter

Fixed Speed Rating						Variable Speed (SOA) Ratings <sup>1</sup>						Product Type	230V Model No.	230/460V Model No.	
Speed (rpm)	Torque (lb-in.)	HP	(230V) A	(230/460V) A	Gear Ratio	Speed Range (rpm)	Frequency Range (Hz)	Torque Type	Torque @ 10 Hz (lb-in.)	Torque @ 60 Hz (lb-in.)	Torque @ 90 Hz (lb-in.)				
<b>42R-5N Gearmotor</b>															
<b>Three-Phase, Inverter Duty, Non-synchronous (TEFC)</b>															
23	121	3/8	1.90	1.90/0.95	75	2.4-31	10-90	constant	116	116	116	42R6BFPP-5N	2270	2870	
43	113				40	4.4-57		constant	109	109	109		2271	2871	
57	109				30	5.9-77		constant	104	104	104		N2275	2875	
85	103				20	8.9-115		constant	98	98	98		2272	2872	
170	101				10	18-229		variable	66	105	101		2273	2873	
340	54				5	35-458		variable	38	68	59		2274	2874	
<b>42R-5L/H Hollow Shaft Gearmotor</b>															
<b>Three-Phase, Inverter Duty, Non-Synchronous (TEFC)</b>															
23	121	3/8	1.90	—	75	2.4-31	10-90	variable	121	121	116	42R6BFPP-5L/H	N2470	—	
43	113			—	40	4.4-57		constant	109	109	109		N2471	—	
57	109			—	30	5.9-77		constant	104	104	104		N2475	—	
85	103			—	20	8.9-115		constant	98	98	98		2472	—	
170	101			—	10	18-229		variable	66	105	101		N2473	—	
340	54			—	5	35-458		variable	38	68	59		N2474	—	



Type 42R-5L/H

**Fixed Speed—AC Gearmotors**



Type 42R-5N

Speed (rpm)	Rated Torque (lb-in.)	Motor HP	V	Hz	Ph	Amps	Gear Ratio	Radial Load (lbs.)	Capacitor (µF/VAC)	Product Type	Model Number	
<b>Permanent Split Capacitor, Non-synchronous</b>												<b>CAPACITOR IS REQUIRED</b>
38	113	1/6	115	60	1	2.1	40	180	15.0/350	42R5BFCL-5N	0678	
75	81						20				0677	
150	47						10				0672	
300	25						5				0670	
<b>Split Phase (with centrifugal switch), Non-synchronous</b>												
43	113	1/6	115	60	1	3.6	40	180	—	42R5BFSL-5N	0648	
85	75						20		0647			
170	43						10		0646			
340	23						5		0645			
<b>Three-phase, Non-synchronous</b>												
43	113	1/4	230	60	3	1.3	40	180	—	42R5BFPP-5N	0634	
85	103						20		0633			
170	67						10		0630			
340	36						5		0629			

**Permanent Magnet DC Gearmotors**



Type 42A-5N

Speed (rpm)	Rated Torque (lb-in.)	Rated Current (Amps)		Peak Torque (lb-in.)	Motor HP	FF	Gear Ratio	Radial Load (lbs.)	Product Type <sup>2</sup>	Accy Shaft	No Accy Shaft	Accy Shaft	No Accy Shaft	
		12/24V	90/130V							12/24V	90/130V			
<b>42A-5N Gearmotor</b>														
<b>12/24V Models With Class F Temperature Rating</b>														
25/62	109	—	177	3/16 / 7/16	1.0	—	40	120	42A5FEPM-5N	5838	5738	—	—	
33/83	104	—	169							30	5837	5737	—	—
50/125	98	17	159							20	5836	5736	—	—
100/250	80	—	91							10	5835	5735	—	—
200/500	43	—	49	5	5834	5734	—	—						
<b>90/130V Models With Class F Temperature Rating</b>														
45/62	109	—	177	3/16 / 1/4	1.4 / 1.0	—	40	120	42A5BEPM-5N	—	—	4538	4138	
60/83	104	—	169							30	—	—	4537	4137
90/125	83	1.9/1.8	159							20	—	—	4536	4136
180/250	44	—	91							10	—	—	4535	4135
360/500	24	—	49	5	—	—	4534	4134						
<b>33A-5L/H Hollow Shaft Gearmotor</b>														
<b>90/130V Models With Class F Temperature Rating</b>														
43/62	84/109	—	177	1/8 / 1/4	1.4 / 1.0	—	40	120	33A5BEPM-5L/H	—	—	—	N6738	
58/83	75/100	—	169							30	—	—	—	N6737
86/125	54/78	1.4/1.8	159							20	—	—	—	N6736
173/250	31/42	—	91							10	—	—	—	6735
345/500	17/22	—	49	5	—	—	—	N6734						



Type 33A-5L/H Hollow Shaft



**Brushless DC Gearmotors**

Speed (rpm)	Rated Torque (lb-in.)	Rated Current (Amps)		Peak Torque (lb-in.)	Motor HP	Gear Ratio	Radial Load (lbs.)	Product Type <sup>2</sup>	Accy Shaft	No Accy Shaft	Accy Shaft	No Accy Shaft
		24V	130V						24V		130V	
		<b>34B-5N Right Angle Gearmotor</b>										
62	109	—	2.7	174	3/8	40	220	34B6BEBL-5N	—	—	—	N3396
62	79	12	2.0	174	1/4	40	230	34B4BEBL-5N	N3691	N3591	N3491	N3391
62	74	9.6	1.5	174	1/5	40	230	34B3BEBL-5N	—	N3586	—	3386
83	104	—	2.6	166	3/8	30	210	34B6BEBL-5N	—	—	—	N3397
83	75	12	2.0	166	1/4	30	210	34B4BEBL-5N	N3692	N3592	N3492	N3392
83	70	9.6	1.6	166	1/5	30	210	34B3BEBL-5N	—	N3587	—	N3387
125	98	—	2.6	156	3/8	20	180	34B6BEBL-5N	—	—	—	N3398
125	75	12	2.0	156	1/4	20	180	34B4BEBL-5N	N3693	N3593	3493	N3393
125	59	9.6	1.5	156	1/5	20	180	34B3BEBL-5N	—	N3588	—	N3388
250	64	—	2.7	161	3/8	10	140	34B6BEBL-5N	—	—	—	3399
250	42	12	2.0	161	1/4	10	140	34B4BEBL-5N	N3694	N3594	N3494	N3394
250	33	9.6	1.6	140	1/5	10	150	34B3BEBL-5N	—	N3589	—	N3389
500	36	—	2.6	142	3/8	5	120	34B6BEBL-5N	—	—	—	N3378
500	24	12	2.0	94	1/4	5	120	34B4BEBL-5N	N3695	N3595	N3495	N3395
500	18.6	9.6	1.6	74	1/5	5	120	34B3BEBL-5N	—	N3590	—	N3390



Type 34B-5N

**INTEGRAMotor BLDC Gearmotors**

Speed (rpm)	Rated Torque (lb-in.)	24V Rated Current (Amps)	Peak Torque (lb-in.)	Motor HP	Gear Ratio	Radial Load (lbs.)	Product Type	Model Number <sup>3</sup>
63	79	12	—	1/4	40	230	34B4FEBL/FV-5N	N3780
83	75		—		30	210	34B4FEBL/FV-5N	N3781
125	75		—		20	180	34B4BEBL/FV-5N	N3782
250	44		—		10	140	34B4BEBL/FV-5N	3783
500	24		—		5	120	34B4BEBL/FV-5N	N3784



Type 34B/FV-5N INTEGRAMotor

up to 121 lb-in. | Right Angle Gearmotors

**5F**

- Unvented gearhousing for universal horizontal mounting
- Bronze worm gear for high shock load capability
- Hardened and ground worm for strength and long life
- Models with accessory shafts are ideal for mounting encoders or brakes
- See page 34 for capacitors and terminal boxes
- See page 39 for reference dimensions

**Fixed Speed—AC Gearmotors**

Speed (rpm)	Rated Torque (lb-in.)	Motor HP	V	Hz	Ph	Amps	Gear Ratio	Radial Load (lbs.)	Capacitor (µF/VAC)	Product Type	Model Number
<b>Permanent Split Capacitor, Non-synchronous</b>											
19 / 23	121 / 102	1/9	115	50 / 60	1	1.8 / 1.4	75	80	12.5 / 250	34R6BFCI-5F	0524
23 / 28	111 / 93						60				N0523
28 / 34	104 / 87						50				N0522
35 / 43	93 / 78						40				0521
47 / 57	83 / 70						30				N0519
70 / 85	60 / 50						20				0518
93 / 113	49 / 41						15				N0514
140 / 170	35 / 29						10				0513
280 / 340	19 / 16						5				N0511



Type 34R-5F

**Permanent Magnet DC Gearmotors**

Speed (rpm)	Rated Torque (lb-in.)	Rated Current (Amps)		Peak Torque (lb-in.)	Motor HP	FF	Gear Ratio	Radial Load (lbs.)	Product Type <sup>2</sup>	Accy Shaft	No Accy Shaft	Accy Shaft	No Accy Shaft
		24V	130V							24V		130V	
		<b>33A5BEPM-5F</b>											
62	55	5.3	0.91	118	1/8	1.0	40	80	33A5BEPM-5F	N6824	N6124	N6544	6144
125	38			83			20			N6825	N6115	6542	6142
250	21			44			10			N6822	N6122	N6541	6141
500	11			23			5			N6820	N6121	N6540	6140



Type 33A-5F

These models feature sleeve bearings on driveshaft.

<sup>1</sup> SOA: Contact the factory for detailed speed/torque information (Safe Operating Area). See page 19.  
<sup>2</sup> The fifth character of the product type changes from "B" to "F" for accessory ready models.  
<sup>3</sup> Type FV INTEGRAMotors require a PWM signal from a motion controller or PLC to operate.  
**"N" model numbers require lead time and minimum quantities.**

# 3RD

## Right Angle Gearmotors | up to 148 lb-in.

- Unvented gearhousing for universal horizontal mounting
- Hardened worm gears
- Face-mount on the drive-shaft side, or bottom-mount is standard
- 42A-5H only: Single and double shaft configurations available
- See page 34 for capacitors and terminal boxes
- See page 39 for reference dimensions

### Variable Speed—Pacesetter Inverter Duty AC Gearmotors



Type 30R-3RD Pacesetter

Fixed Speed Rating					Variable Speed (SOA) Ratings <sup>1</sup>						Product Type	230V Model Number
Speed (rpm)	Torque (lb-in.)	Motor HP	A	Gear Ratio	Speed Range (rpm)	Frequency Range (Hz)	Torque Type	Torque @ 10 Hz (lb-in.)	Torque @ 60 Hz (lb-in.)	Torque @ 90 Hz (lb-in.)		
0.5	95	1/25	0.38	3600	0.1-0.6	10-90	Constant	95	95	95	30R2BEPP-3RD	N8036
1.2	126	1/25	0.38	1400	0.2-1.5			121	121	121	30R2BEPP-3RD	N8014
2.8	148	1/17	0.48	600	0.2-3.6			148	148	148	30R4BEPP-3RD	8006
5.7	146	1/17	0.48	300	0.4-7.2			146	146	146	30R4BEPP-3RD	N8003
8.5	141	1/17	0.48	200	0.7-0.11			141	141	141	30R4BEPP-3RD	N8002

### Fixed Speed—AC Gearmotors



Type 30R-3RD

Speed (rpm)	Rated Torque (lb-in.)	Motor HP	V	Hz	Ph	Amps	Gear Ratio	Radial Load (lbs.)	Capacitor (µF/VAC)	Product Type	Model Number
Permanent Split Capacitor, Non-synchronous										<b>CAPACITOR IS REQUIRED</b>	
0.4	95	1/30	115	60	1	0.5	3600	160	5.0/250	30R2BEPI-3RD	N8536
1.1	126	1/30				0.5	1400		5.0/250	30R2BEPI-3RD	N8514
2.6	148	1/27				0.49	600		9.0/250	30R4BEPI-3RD	N8506
5.2	101	1/27				0.49	300		9.0/250	30R4BEPI-3RD	N8503
7.8	88	1/27				0.49	200		9.0/250	30R4BEPI-3RD	N8502

### Permanent Magnet DC Gearmotors



Type 24A-3RD

Speed (rpm)	Rated Torque (lb-in.)	24V Rated Current (A)	130V Rated Current (A)	Motor HP	FF	Gear Ratio	Radial Load (lbs.)	Product Type <sup>2</sup>	24V Model Number	130V Model Number
0.7	95	1.8	—	1/25	1.0	3600	160	24A2BEPM-3RD	N4336	—
0.7	95	—	0.3	1/29		3600		24A2BEPM-3RD	—	N4036
1.8	126	1.8	—	1/25		1400		24A2BEPM-3RD	N4314	—
1.8	126	—	0.3	1/29		1400		24A2BEPM-3RD	—	N4014
4.2	147	2.6	0.48	1/17		600		24A4BEPM-3RD	N4306	N4006
8.3	108	2.6	0.48	1/17	300	24A4BEPM-3RD	N4303	4003		
12.5	92	2.6	0.48	1/17	200	24A4BEPM-3RD	N4302	N4002		

### Brushless DC Gearmotors



Type 22B-3RD

Speed (rpm)	Rated Torque (lb-in.)	24V Rated Current	130V Rated Current	Motor HP	Gear Ratio	Radial Load (lbs.)	Product Type <sup>2</sup>	24V Model Number	130V Model Number
0.7	95	2.8	0.48	1/16	3600	160	22B2BEBL-3RD	N5336	N5036
1.8	126	2.8	0.48	1/16	1400		22B2BEBL-3RD	5314	N5014
4.2	147	2.8	0.48	1/16	600		22B2BEBL-3RD	N5306	N5006
8.3	144	5.9	0.89	1/8	300		22B4BEBL-3RD	N5303	N5003
12.5	140	5.9	0.89	1/8	200		22B4BEBL-3RD	N5302	N5002

# 5H

## Right Angle Gearmotors | up to 296 lb-in.

### Variable Speed—Pacesetter Inverter Duty AC Gearmotors



Type 48R-5H Pacesetter

Fixed Speed Rating					Variable Speed (SOA) Ratings <sup>1</sup>						Product Type	230/460V Model Number
Speed (rpm)	Torque (lb-in.)	Motor HP	(230/460V) Amps	Gear Ratio	Speed Range (rpm)	Frequency Range (Hz)	Torque Type	Torque @ 10 Hz (lb-in.)	Torque @ 60 Hz (lb-in.)	Torque @ 90 Hz (lb-in.)		
Three-Phase, Inverter Duty, Non-synchronous (TEFC)												
35	296	3/4	2.7/1.3	48	3.3-48	10-90	constant	272	272	272	48R6BFPP-5H	N2280
47	285			36	4.4-63		constant	262	262	262		2281
94	256			18	8.9-127		constant	234	234	234		N2282
170	178			10	16-228		variable	152	210	180		N2283

### Permanent Magnet DC Gearmotors



Type 42A-5H

Speed (rpm)	Rated Torque (lb-in.)	Rated Current (Amps)		Peak Torque (lb-in.)	Motor HP	FF	Gear Ratio	Radial Load (lbs.)	Product Type <sup>2</sup>	Accy Shaft	No Accy Shaft	Accy Shaft	No Accy Shaft
		24V	130V							24V		130V	
Single Shaft Gearmotor													
52	189	12	2.3	340	1/3	1.0	48	150	42A7BEPM-5H	N4829	N4729	N4599	4199
69	151			316			36			N4828	N4728	N4598	4198
139	87			186			18			N4827	N4727	N4596	N4196
250	52			104			10			N4826	N4726	N4594	4194
Double Shaft Gearmotor													
52	264	15	3.3	340	1/2	1.0	48	150*	42A7BEPM-5H	N4833	N4733	N4503	N4103
69	218			340			36			N4832	N4732	N4502	4102
139	129			286			18			N4831	N4731	N4501	4101
250	71			158			10			4830	N4730	N4500	N4100

\*only on one of the two shafts

- Unvented gearhousing for universal horizontal mounting
- Hardened helical output gearing
- Bronze worm gear for high shock load capability
- Hardened and ground worm hobbled on the motor shaft for high strength and long life
- Models with accessory shafts are ideal for mounting encoders or brakes
- See page 34 for capacitors and terminal boxes
- See pages 39 and 40 for reference dimensions

**Variable Speed—Pacesetter Inverter Duty AC Gearmotors**

Fixed Speed Rating					Variable Speed (SOA) Ratings <sup>1</sup>							Product Type	230V Model Number
Speed (rpm)	Torque (lb-in.)	Motor HP	Amps	Gear Ratio	Speed Range (rpm)	Frequency Range (Hz)	Torque Type	Torque @ 10 Hz (lb-in.)	Torque @ 60 Hz (lb-in.)	Torque @ 90 Hz (lb-in.)			
<b>Three-Phase, Inverter Duty, Non-synchronous (TEFC)</b>													
6	380	3/8	1.9	280	0.6-8.2	10-90	constant	380	380	380	42R6BFPP-GB	N2236	
14	290			120	1.5-19			290	290	290		2237	
28	230			60	3.0-38			230	230	230		N2238	
<b>Hollow Shaft</b>													
6	380	3/8	1.9	280	0.6-8.2	10-90	constant	380	380	380	42R6BFPP-GB/H	2336	
14	290			120	1.5-19			290	290	290		N2337	
28	230			60	3.0-38			230	230	230		N2338	



Type 42R-GB and 42R-GB/H Hollow Shaft (Pacesetter)

**Fixed Speed—AC Gearmotors**

Speed (rpm)	Rated Torque (lb-in.)	Motor HP	V	Hz	Ph	Amps	Gear Ratio	Radial Load (lbs.)	Capacitor (µF/VAC)	Product Type	Model Number
<b>Permanent Split Capacitor, Non-synchronous</b>											
<b>CAPACITOR IS REQUIRED</b>											
5.9	380	1/6	115	60	1	2.0	280	200	25.0/370	42R5BFCL-GB	5266
8.9	375										N5264
14	290										5262
21	278										N5261
28	209										5260
<b>Three-phase, Non-synchronous</b>											
5.9	380	1/4	230/460	60	3	1.2/0.6	280	200	—	42R5BFPP-GB	N5276
8.9	375						N5274				
14	290						N5272				
21	307						N5271				
28	230						N5270				
<b>Permanent Split Capacitor, Non-synchronous Hollow Shaft</b>											
<b>CAPACITOR IS REQUIRED</b>											
5.9	380	1/6	115	60	1	2.0	280	200	25.0/370	42R5BFCL-GB/H	N8266
8.9	375						N8264				
14	290						N8262				



Type 42R-GB and 42R-GB/H Hollow Shaft

**Permanent Magnet DC Gearmotors**

Speed (rpm)	Rated Torque (lb-in.)	Rated Current (Amps)		Peak Torque (lb-in.)	Motor HP	FF	Gear Ratio	Radial Load (lbs.)	Product Type <sup>2</sup>	Accy Shaft		No Accy Shaft	
		24V	90/130V							24V	90/130V		
<b>33A-GB 90/130V Models With Class F Temperature Rating</b>													
6.2 / 8.9	380 / 380	—	1.4 / 1.8	600	1/8 / 1/4	1.4 / 1.0	280	200	33A5BEPM-GB	6866	6766	6466	6066
9.1 / 13	358 / 375			600						6864	6764	6464	6064
14 / 21	251 / 290			464						6862	6762	6462	6062
29 / 42	151 / 200			368						6860	6760	6460	6060
<b>90/130V Hollow Shaft</b>													
6.2 / 8.9	380 / 380	—	1.4 / 1.8	600	1/8 / 1/4	1.4 / 1.0	280	200	33A5BEPM-GB/H	—	—	—	7066
9.1 / 13	358 / 375			600						—	—	—	7064
14 / 21	251 / 290			464						—	—	—	7062
29 / 42	151 / 200			368						—	—	—	7060
<b>42A-GB 130 V Models With Class B Temperature Rating</b>													
										<b>24V</b>		<b>130V Only</b>	
8.9	380	8.8	1.8	600	1/4	1.0	280	200	42A5BEPM-GB	N4866	N4766	N4466	4066
13	375			600						N4864	N4764	N4464	4064
21	290			464						N4862	N4762	N4462	4062
42	213			368						N4860	N4760	N4460	4060
<b>130 V Models With Class B Temperature Rating Hollow Shaft, Accessory Ready</b>													
8.9	380	8.8	1.8	600	1/4	1.0	280	200	42A5FEPM-GB/H	—	—	7466	—



Type 33A-GB



Type 33A-GB/H Hollow Shaft



Type 42A-GB



Type 42A-GB/H Hollow Shaft

**Save Time, Space and Money with Hollow Shaft Gearmotors**

Hollow shaft gearmotors connect directly to the driven load, reducing the overall space required by the gearmotor and eliminating expensive shaft couplings, mounting hardware, chains and sprockets. Hollow shaft flange mounting can also eliminate the need for a support bearing one side of a conveyor roller.

<sup>1</sup> SOA: Contact the factory for detailed speed/torque information (Safe Operating Area). See page 19.

<sup>2</sup> The fifth character of the product type changes from "B" to "F" for accessory ready models.

"N" model numbers require lead time and minimum quantities.



# Motors without Gearing

Bodine offers a full range of fractional horsepower motors.

## AC fixed and variable speed motors

are available with voltage ratings of 115 VAC, 60 Hz (single-phase), 230 VAC, 60 Hz (3-phase) and 230/460 VAC, 60 Hz (3-phase). They are offered with three winding types: permanent split capacitor, split phase, and three-phase. **PMDC**

**motors** are available with voltage ratings from 12 to 180 VDC. **Brushless DC**

**motors** are available with voltage ratings of 24 or 130 VDC.



## AC

### Torque Motors | from 3.5 to 68 oz.in.

- Will operate satisfactorily on 50 or 60 Hz
- Totally enclosed non-ventilated IP-20 rating
- Provides excellent performance for holding, winding and tensioning applications
- Provides locked rotor or reverse torque intermittently at rated voltage, or continuously at reduced voltage
- Permanently lubricated, noise tested ball bearings
- Locked bearing design on 30R, 42R, and 48R minimizes shaft endplay
- See page 34 for capacitors and accessories
- See pages 41 and 42 for reference dimensions

#### AC Torque Motors (for holding applications)



V	Hz	Locked Rotor Performance				rpm @ No Load	Capacitor (µF/VAC)	Product Type	Model Number
		% Duty Cycle	Torque (oz-in.)	Watts	Max. On Time (min.)				
<b>KCI</b>									
<b>CAPACITOR IS INCLUDED</b>									
115	60	40	7.0	22	5	1580	2.3/250	KCI-26	0621
83	60	100	3.5	12	—	1570			
115	50	40	6.0	19	5	1310	5.0/250	30R2FEC1	5625
92	50	100	4.0	13	—	1300			
<b>30R</b>									
<b>CAPACITOR IS REQUIRED</b>									
115	60	50	25	52	30	1660	7.5/370	42R6FEC1	2628
100	60	100	19	40	—	1645			
115	50	50	25	47	30	1425	12.5/370	48R6FEC1	0632
100	50	100	19	36	—	1420			
<b>42R</b>									
<b>CAPACITOR IS REQUIRED</b>									
115	60	40	38	85	28	1690	12.5/370	48R6FEC1	0632
87	60	100	22	49	—	1680			
115	50	40	38	82	28	1445	12.5/370	48R6FEC1	0632
87	50	100	22	47	—	1435			
<b>48R</b>									
<b>CAPACITOR IS REQUIRED</b>									
115	60	40	65	120	15	1560	12.5/370	48R6FEC1	0632
80	60	100	32	60	—	1560			
115	50	40	68	96	15	1370	12.5/370	48R6FEC1	0632
80	50	100	34	58	—	1360			

### Typical Performance Curves at 115V, 60 Hz

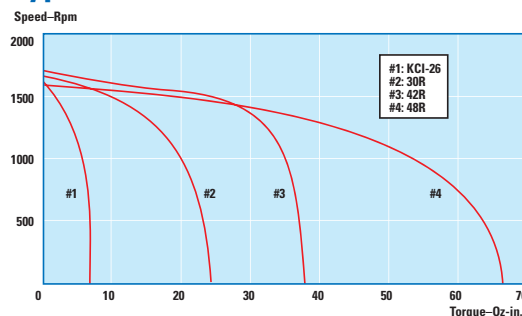

- Quinsulation™, 5-stage insulation system designed to meet NEMA MG 1-1993, Section IV, Part 31
- Most standard models are available with either 230VAC, 60Hz, 3-phase or 230/460V, 60Hz 3-phase
- Inverter-grade magnet wire and Class F insulation system for increased protection against spikes and corona damage caused by the inverter
- UL recognized for construction, CSA certified, and in compliance with the Low Voltage Directive “CE”
- See page 34 for capacitors and terminal boxes
- See pages 41 and 42 for reference dimensions

Variable Speed— Type 30R — 1/25-1/17 HP

Fixed Speed Ratings				Variable Speed (SOA) Ratings <sup>1</sup>					Product Type	230V Model Number	
Speed (rpm)	Torque (oz-in.)	HP	Amps	Speed Range (rpm)	Frequency Range (Hz)	Torque Type	Torque @				
							10 Hz (oz-in.)	60 Hz (oz-in.)	140 Hz (oz-in.)		
1700	24	1/25	0.38	220-3150	10-140	variable	20	56	27	30R2BEPP	N2200
	35	1/17	0.48	133-3240			45	66	35	30R4BEPP	2201



Type 30R Pacesetter

Variable Speed— Type 34R — 1/8-1/4 HP

Fixed Speed Ratings					Variable Speed (SOA) Ratings <sup>1</sup>					Product Type	230V Model Number	230/460V Model Number	
Speed (rpm)	Torque (oz-in.)	HP	(230V) Amps	(230/460V) Amps	Speed Range (rpm)	Frequency Range (Hz)	Torque Type	Torque @					
								10 Hz (oz-in.)	60 Hz (oz-in.)	Max. Hz (oz-in.)			
<b>Three-Phase, Inverter Duty, Non-synchronous Motor (TEFC)</b>													
1700	148	1/4	1.2	1.2/0.60	220-3650	10-140	variable	120	247	90	34R6BFPP	2295	2895
<b>Three-Phase, Inverter Duty, Synchronous Motor (TEFC)</b>													
1800	70	1/8	1.4	—	300-2400	10-80	variable	54	103	48	34R6BFYP	2299	—



Type 34R Pacesetter

Variable Speed— Type 42R — 3/8 HP

Fixed Speed Ratings					Variable Speed (SOA) Ratings <sup>1</sup>					Product Type	230V Model Number	230/460V Model Number	
Speed (rpm)	Torque (oz-in.)	HP	(230V) Amps	(230/460V) Amps	Speed Range (rpm)	Frequency Range (Hz)	Torque Type	Torque @					
								10 Hz (oz-in.)	60 Hz (oz-in.)	140 Hz (oz-in.)			
<b>Three-Phase, Inverter Duty, Non-synchronous Motor (TEFC), Base Mount</b>													
1700	222	3/8	1.9	1.9/.95	177-3500	10-140	variable	170	281	137	42R6BFPP	2235	2835
<b>Three-Phase, Inverter Duty, Non-synchronous Motor (TEFC), NEMA C Face Mount</b>													
1700	222	3/8	1.9	1.9/.95	177-3500	10-140	variable	170	281	137	42R6BFPP	N2234	2834



Type 42R Pacesetter

Variable Speed— Type 48R — 1/3-3/4 HP

Fixed Speed Ratings					Variable Speed (SOA) Ratings <sup>1</sup>					Product Type	230/460V Model Number	
Speed (rpm)	Torque (oz-in.)	HP	(230/460V) Amps		Speed Range (rpm)	Frequency Range (Hz)	Torque Type	Torque @				
								10 Hz (oz-in.)	60 Hz (oz-in.)	Max. Hz (oz-in.)		
<b>Three-Phase, Inverter Duty, Non-synchronous Motor (TEFC)</b>												
1700	445	3/4	2.7/1.3		160-3600	10-140	variable	412	675	220	48R6BFPP	2240
<b>Three-Phase, Inverter Duty, Synchronous Motor (TEFC), Face Mount</b>												
1800	185	1/3	2.4/1.2		300-2400	10-80	variable	220	262	125	48R5BFYP	2244



Type 48R Pacesetter

<sup>1</sup> SOA: Contact the factory for detailed speed/torque information (Safe Operating Area). See page 19. “N” model numbers require lead time and minimum quantities.

### Safe Operating Torque and Speed Area (SOA)

Rated Torque is either the value of torque which corresponds to nameplate output power and speed at 60 Hz, or it is the maximum torque at gear strength limits (rated torque can be either motor limited or gear-limited).

SOA Torque is defined as the maximum torque at which the motor still operates within Class F thermal limits, or as the maximum torque of a gearmotor when it is gear-limited. Continuous duty operation must be limited to the area below the

SOA or gear-limited torque curves. The SOA torque for synchronous motors is close to the pull-in torque; that is, the motor will pull out of synchronism if the required torque exceeds the SOA torque.

Examples of typical “SOA” Graphs. Contact our technical support staff for specific SOA information.

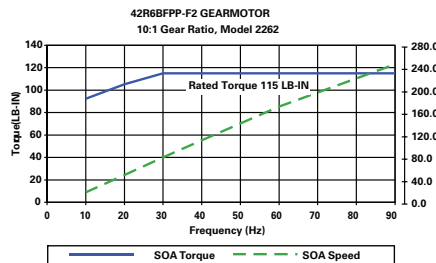
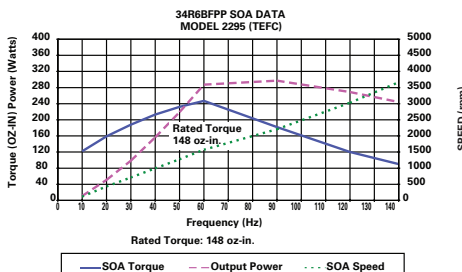

- Totally enclosed IP-20 rating
- Fan cooled for high output power
- Class B insulation system operated within Class A limits to prolong winding and lubricant life
- Locked bearing design minimizes shaft endplay
- Locked bearing design on 30R, 34R, 42R, and 48R minimizes shaft endplay
- See page 34 for capacitors and accessories
- See pages 41 and 42 for reference dimensions

Fixed Speed—Type K-2 1/1600-1/200 HP



Type K-2

Speed (rpm)	Rated Torque (oz-in.)	HP	V	Hz	Ph	Amps	Radial Load (lbs.)	Capacitor (µF/VAC)	Product Type	Model Number
<b>Permanent Split Capacitor, Non-synchronous</b> <span style="float:right"><b>CAPACITOR IS INCLUDED</b></span>										
1550	1.4	1/450	115	60		0.08		1.0/250	KCI-23	0705
1550	2.2	1/300	115	60	1	0.104	5.7	1.3/250	KCI-24	0712
1550	3.2	1/200	115	60		0.124		1.6/250	KCI-26	0713
<b>Permanent Split Capacitor, High Slip, Non-synchronous</b> <span style="float:right"><b>CAPACITOR IS INCLUDED</b></span>										
1200	1.1	1/800	115	60	1	0.082	5.7	1.0/250	KCI-23	0707
	1.8	1/450				0.098		1.2/250	KCI-24	0714
<b>Permanent Split Capacitor, Synchronous</b> <span style="float:right"><b>CAPACITOR IS INCLUDED</b></span>										
1800	0.35	1/1600				0.077		1.0/250	KYC-23	0701
1800	0.62	1/900	115	60	1	0.091	5.7	1.3/250	KYC-24	0709
3600	0.31	1/900				0.102		1.6/250	KYC-24	0710

Fixed Speed—Type 30R 1/40-1/30 HP



Type 30R

Speed (rpm)	Rated Torque (oz-in.)	HP	V	Hz	Ph	Amps	Radial Load (lbs.)	Capacitor (µF/VAC)	Product Type	Model Number
<b>Permanent Split Capacitor, Non-synchronous</b> <span style="float:right"><b>CAPACITOR IS REQUIRED</b></span>										
1700	20					0.45				5240
3400	10	1/30	115	60	1	0.47	18	5.0/250	30R2BECI	5219
<b>Permanent Split Capacitor, High Slip, Non-synchronous</b> <span style="float:right"><b>CAPACITOR IS REQUIRED</b></span>										
1800	14	1/40	115	60	1	0.52	18	5.0/250	30R2BEYC	5246

Fixed Speed—Type 34R 1/15-1/5 HP



Type 34R

Speed (rpm)	Rated Torque (oz-in.)	HP	V	Hz	Ph	Amps	Radial Load (lbs.)	Capacitor (µF/VAC)	Product Type	Model Number
<b>Permanent Split Capacitor, Non-synchronous</b> <span style="float:right"><b>CAPACITOR IS REQUIRED</b></span>										
1700	39	1/15				1		10.0/250	34R4BFCI	0290
1700	65	1/9	115	60	1	1.4	50	12.5/250	34R6BFCI	0291
3400	42	1/7				1.75		15.0/250	34R6BFCI	0293
<b>Permanent Split Capacitor, Synchronous</b> <span style="float:right"><b>CAPACITOR IS REQUIRED</b></span>										
1800	38	1/15	115	60	1	1.5	50	15.0/250	34R6BFYC	N0297
<b>Three-phase, Non-synchronous</b>										
1700	119	1/5	230	60	3	1.2	50	—	34R6BFPP	0295
<b>Three-phase, Synchronous</b>										
1800	70	1/8	230	60	3	1.4	50	—	34R6BFYP	0299
<b>Permanent Split Capacitor, Three-Wire Reversible, Non-Synchronous</b> <span style="float:right"><b>CAPACITOR IS REQUIRED</b></span>										
1700	85	1/7	115	60		1.7		27.5/250	34R6BFCI	0294
1400/1700	74	1/8	230	50/60	1	0.8/0.7	50	6.0/450	34R6BFCI	0296

Common Abbreviations

<b>BLDC</b>	Brushless DC
<b>FF</b>	Form Factor—A measurement which indicates to what degree rectified current departs from pure DC. A higher form factor increases the heating effect of the motor and reduces brush life. <sup>1</sup>
<b>IP-44</b>	Ingress Protection Rating—Protection against sprays from all directions—limited ingress permitted. <sup>2</sup>
<b>NEMA-12</b>	Enclosures (without knockouts) for indoor use. Provides a degree of protection to personnel against access to hazardous parts and to the equipment inside against ingress of solid objects, and lightly splashed liquids. <sup>3</sup>
<b>NEMA-4</b>	Enclosures constructed for either indoor or outdoor use. Protects personnel against access to hazardous parts. Protects equipment inside the enclosure against ingress of solid objects and rain, sleet, snow, splashing water, and hose-directed water. <sup>3</sup>
<b>PMDC</b>	Permanent magnet DC
<b>TEFC</b>	Totally enclosed, fan cooled
<b>TENV</b>	Totally enclosed, non-ventilated

1. Bodine Handbook, fifth edition. Chicago, 1993; 2. American National Standards Institute ANSI/IEC 60529-2004; 3. NEMA.org, NEMA 250-2003



**Fixed Speed – Type 42R 1/12-1/4 HP**

Speed (rpm)	Rated Torque (oz-in.)	HP	V	Hz	Ph	Amps	Radial Load (lbs.)	Capacitor (µF/VAC)	Product Type	Model Number	Model with Base Mount
<b>Permanent Split Capacitor, Non-synchronous</b> <span style="float: right;"><b>CAPACITOR IS REQUIRED</b></span>											
1700	101	1/6	115	60	1	1.9	50	15.0/350	42R5BFCI	0260	0258
<b>Split phase (with centrifugal switch), Non-synchronous</b>											
1700	48	1/12	115	60	1	2.4	50	—	42R3BFSI	N0261	0251
1700	101	1/6				3.6			42R5BFSI	0254	0253
3450	50	1/6				3.3			42R5BFSI	N0265	0255
<b>Three-phase, Non-synchronous</b>											
1700	148	1/4	230	60	3	1.2	50	—	42R5BFPP	N0263	0273
			230/460			1.2/0.6				N0264	0274



Type 42R

**Fixed Speed – Type 48R 1/3-1/2 HP**

Speed (rpm)	Rated Torque (oz-in.)	HP	V	Hz	Ph	Amps	Radial Load (lbs.)	Capacitor (µF/VAC)	Product Type	Model Number
<b>Permanent Split Capacitor, Non-synchronous</b> <span style="float: right;"><b>CAPACITOR IS REQUIRED</b></span>										
1700	196	1/3	115	60	1	4.0/2.0	205	20.0/370	48R6BFCI	0283
			230					12.5/370		
<b>Split Phase, Non-Synchronous (With Centrifugal Switch)</b>										
1700	196	1/3	115/230	60	1	4.8/2.4	205	—	48R6BFSI	0284
<b>Three-phase, Non-Synchronous</b>										
1400	296	1/2	230	50	3	2.0	205	—	48R6BFPP	0286
1700			230	60		1.7				
1400			460	50		1.0				
1700			460	60		0.85				
<b>Three-phase, Synchronous</b>										
1800	185	1/3	230/460	60	3	2.5/1.3	205	—	48R5BFYP	0281



Type 48R

“N” model numbers require lead time and minimum quantities.

## Comparative Advantages of AC Motors and Gearmotors

This table illustrates some of the capabilities, advantages, and disadvantages of common AC motor and gearmotors designs.

Motor Winding	Speed Tolerance	Typical Rated Speeds at 60Hz	Start/Stop Frequency	Coast without Brake	Coast with Dynamic Braking	Starting Torque (% of Rated Torque)	Pros	Cons
Split Phase (SI)	±3%	1700-1750 (4-pole) 3450 (2-pole)	Up to 6/hour	20-600 rev.	0.5-6 rev.	175% and up	No capacitors	Switch life 50k to 250k starts
Permanent Split Capacitor (CI)	±3%	1700-1750 (4-pole) 3450 (2-pole)	Up to 10/min.	20-600 rev.	0.5-6 rev.	90-100%	Very reliable, Low starting current	Low starting torque
Three Phase (PP, Non-synchronous)	±3%	1700-1750 (4-pole) 3450 (2-pole)	Up to 10/min.	20-600 rev.	0.5-6 rev.	200-400%	Most reliable and efficient, No cap/switch	Requires three-phase power supply

## Variable Speed Drive Systems

	Requires Brushes	High Torque at Speeds Above and Below Rated	Noise Level	Performance	Speed Range
Variable Speed AC	No	No	Higher	Limited	Limited
PMDC System	Yes	Yes	Highest	Good	Widest
BLDC System	No	Yes	Lowest	Best	Widest

- Totally Enclosed, Non-Ventilated (IP-40)
- Class F insulation, Class B rating
- Skewed armature for smooth low speed operation
- High starting torque and self-braking
- Oversized magnets resist demagnetization, stabilized to common strength for consistent performance
- Locked bearing minimizes endplay
- Models with accessory shafts are ideal for mounting encoders or brakes
- See page 34 for accessories
- See pages 41 and 42 for reference dimensions

PMDC Type 24A | 1/50-1/7 HP



Speed (rpm)	Rated Torque (oz-in.)	Current (Amps)	HP	FF	K <sub>T</sub> (oz-in/A)	K <sub>E</sub> (V/krpm)	Wdg. Res. (Ohms)	Winding Ind. (mH)	Inertia (oz-in-sec. <sup>2</sup> )	Radial Load (lbs.)	Product Type <sup>2</sup>	24V Winding		130V Winding	
												Accy Shaft	No Accy Shaft	Base No Accy Shaft	Flange No Accy Shaft
2500	8	1.2	1/50	1.0	8.3	6.1	5.7	6.7	0.003	25	24A0BEPM	N4440	N0040	—	—
2500	8	0.22	1/50		42	31	176	220	0.003		24A0BEPM	—	—	N4439	N0039
2500	16	1.8	1/29		10	7.5	2.5	3.6	0.005		24A2BEPM	N4445	0045	—	—
2500	14	0.3	1/29		55	41	84	133	0.005		24A2BEPM	—	—	0042*	N4441 0041
2500	22	2.6	1/18		9.2	6.8	2	6.7	0.007		24A4BEPM	N4444	0044	—	—
2500	24	0.45	1/17		55	40	5	184	0.007		24A4BEPM	—	—	—	0047 0043
11,500	12	1.1	1/7		14	10	3.15	4.5	0.007		24A4BEPM	—	—	0049*	—

\* These models ship with a factory installed base mounting kit.

PMDC Type 33A | 1/16-1/3 HP



Speed (rpm)	Rated Torque (oz-in.)	Current (Amps)	HP	FF	K <sub>T</sub> (oz-in/A)	K <sub>E</sub> (V/krpm)	Wdg. Res. (Ohms)	Winding Ind. (mH)	Inertia (oz-in-sec. <sup>2</sup> )	Radial Load (lbs.)	Product Type <sup>2</sup>	24V Winding		130V Winding	
												Accy Shaft	No Accy Shaft	Accy Shaft	No Accy Shaft
<b>24V, Class F Temperature Rating</b>															
2500	50	5.5	1/8	1.0	10.2	7.5	0.66	1.9	0.031	55	33A3BEPM	N6424	6024	—	—
	95	9.2	1/4		11.1	8.2	0.29	0.98	0.043		33A5BEPM	—	6021	—	—
	134	12	1/3		11.5	8.5	0.31	0.59	0.075		33A7BEPM	N6422	6022	—	—
<b>90/130 V Class F Temperature Rating</b>															
1725 / 2500	36/50	.78 / 1.0	1/16 / 1/8	1.4 / 1.0	56	42	22	0.57	0.031	55	33A3BEPM	—	—	6434	6034
	73/95	1.4 / 1.8	1/8 / 1/4		60	44	11	0.28	0.043		33A5BEPM	—	—	6435	6035
	97/134	1.8 / 2.4	1/6 / 1/3		66	49	8.8	0.18	0.075		33A7BEPM	—	—	—	6037

PMDC Type 42A | 1/4-1/2 HP



Speed (rpm)	Rated Torque (oz-in.)	Current (Amps)	HP	FF	K <sub>T</sub> (oz-in/A)	K <sub>E</sub> (V/krpm)	Winding Res. (Ohms)	Winding Ind. (mH)	Inertia (oz-in-sec. <sup>2</sup> )	Radial Load (lbs.)	Product Type <sup>2</sup>	24V Winding		130V Winding	
												Accy Shaft	No Accy Shaft	Accy Shaft	No Accy Shaft
<b>NEMA 42C Face Mount, Class B Temperature Rating</b>															
2500	101	8.8	1/4	1.0	12	9.2	0.27	0.64	0.082	90	42A5BEPM	N4421	N4021	—	—
	101	1.8	1/4		60	44	5.5	20	0.082		42A5BEPM	—	—	4435	4035
	135	12	1/3		12	9	0.16	0.45	0.12		42A7BEPM	N4422	N4022	—	—
	135	2.3	1/3		64	47	4.2	17	0.12		42A7BEPM	—	—	N4437	4037
<b>NEMA 42CZ Face Mount, Class F Temperature Rating</b>															
2500	150	15	1/3	1.0	11	8	0.18	0.61	0.082	90	42A5BEPM	N4800	N4601	—	—
	150	2.7	1/3		60	45	3.2	—	0.082		42A5BEPM	—	—	N4430	N4031
	180	19	1/2		11.5	8.5	0.12	0.54	0.12		42A7BEPM	N4802	N4603	—	—
	180	3.4	1/2		57	42	2.7	—	0.12		42A7BEPM	—	—	N4432	4033

<sup>2</sup> The fifth digit of the product type changes from "B" to "F" for accessory ready models. "N" model numbers require lead time and minimum quantities.

Speed Regulation of Permanent Magnet DC Motors

In a PMDC motor, speed is proportional to voltage and torque is proportional to current. When voltage is held constant, the amount that speed drops due to increasing torque is called "speed regulation". The thin blue lines illustrate motor performance without the aid of a regulating electronic control. The heavy red lines illustrate performance from a control with "excellent" (1-3%) speed regulation.

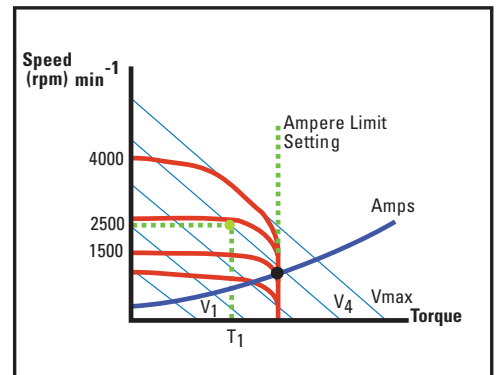

- Quiet operation, low electromagnetic interference (EMI)
- No brush maintenance or contamination from brush dust
- See page 41 for reference dimensions
- See page 34 for accessories

**Brushless DC—Type 22B | 1/16-1/5 HP**

Speed (rpm)	Rated Torque (oz-in.)	HP	Torque Constant (oz-in./A)	Voltage Constant (V/krpm)	Winding		Rotor Inertia (oz-in.-sec. <sup>2</sup> )	Radial Load (lb.)	Product Type <sup>2</sup>	Accy Shaft	No Accy Shaft	Accy Shaft	No Accy Shaft
					Res. (Ohms)	Induct. (mH)				24V		130V	
2500	25	1/16	8.4	5.8	1.2	2.1	0.0036	25	22B2BEBL	N3602	3502	—	—
2500	25	1/16	47	35	40	70	0.0036		22B2BEBL	—	—	—	3302
2500	50	1/8	9	6.7	0.52	1.1	0.0072		22B4BEBL	3604	N3504	—	—
2500	50	1/8	50	37	15	40	0.0072		22B4BEBL	—	—	3404	3304
10,000	20	1/5	14	9.8	4.8	10	0.0072		22B4BEBL	—	—	—	3314



Type 22B

**Brushless DC—Type 34B | 1/5-3/8 HP**

Speed (rpm)	Rated Torque (oz-in.)	HP	Torque Constant (oz-in./A)	Voltage Constant (V/krpm)	Winding		Rotor Inertia (oz-in.-sec. <sup>2</sup> )	Radial Load (lb.)	Product Type <sup>2</sup>	Accy Shaft	No Accy Shaft	Accy Shaft	No Accy Shaft
					Res. (Ohms)	Induct. (mH)				24V		130V	
2500	81	1/5	8.8	6.6	0.3	0.54	0.0115	42	34B3BEBL	3600	3500	—	—
2500	81	1/5	51	38	9.2	24	0.0115		34B3BEBL	—	—	3406	3306
2500	101	1/4	9.0	6.7	0.17	0.40	0.0154		34B4BEBL	—	N3507	—	—
2500	101	1/4	51	38	5.8	14	0.0154		34B4BEBL	—	—	—	3307
2500	151	3/8	9.0	6.7	0.087	0.246	0.0215		34B6BEBL	N3609	N3509	—	—
2500	151	3/8	57	42	3.4	11	0.0215		34B6BEBL	—	—	3409	3309
10,000	33	1/3	14.5	10.7	1.7	4.6	0.0154		34B4BEBL	—	—	—	3317



Type 34B

**INTEGRAmotor BLDC—Type 22B | 1/16-1/4 HP**

Motor Output		Torque Constant (oz-in./A)	Voltage Constant (V/krpm)	Winding		Rotor Inertia (oz-in.-sec. <sup>2</sup> )	Control Input			Product Type	Model Number		
Speed Range (rpm)	Torque (oz-in.)			Res. (Ohms)	Induct. (mH)		HP	Volts (VDC)	Continuous Amps		Type SR	Type FV	
Type SR	Type FV									Analog Interface	Digital Interface <sup>3</sup>		
<b>22B INTEGRAmotor</b>													
200-2500	75-2500	25	47	35	40	70	0.004	1/16	24	3.3	22B2BEBL/**	3802	N3702
		50	50	37	15	40	0.007	1/8			4.4	22B4BEBL/**	3804
<b>34B INTEGRAmotor</b>													
—	60-2500	100	9.6	7.1	0.18	0.43	0.0154	1/4	24	12	34B4FEBL/FV	—	3708



Type 22B/SR and 22B/FV INTEGRAmotor



Type 34B/FV INTEGRAmotor

<sup>1</sup> SOA: Contact the factory for detailed speed/torque information (Safe Operating Area). See page 19.  
<sup>2</sup> The fifth character of the product type changes from "B" to "F" for accessory ready models.  
<sup>3</sup> Type FV INTEGRAmotors require a PWM signal from a motion controller or PLC to operate.  
 \*\* INTEGRAmotor can be ordered with either analog (/SR) or digital (/FV) interface option.  
 "N" model numbers require lead time and minimum quantities.

**High-Performance Direct Drive Brushless DC System**

The e-TORQ motors employ a unique electromagnetic design to improve efficiency, minimize size, and maximize torque. They are ideal for OEM applications where high torque, very compact design, enclosed construction, and economy are necessary.

- Zero cogging over full speed range
- Very high efficiency
- Supplied with encoder
- Maximum torque linearity
- Ten times peak torque is available
- See page 43 for reference dimensions

DC Bus Voltage (VDC)	Continuous Rating				Peak Ratings			Motor Constants				Model Number
	Speed (rpm)	Torque (lb-in.)	Current (Amps)	Power Output (Watts)	Speed (rpm)	Torque (lb-in.)	Current (A-rms)	Ke (V/krpm)	Kt (lb-in./Amp)	Resistance (Ohms)	Inductance (mH)	
<b>7 in. e-TORQ Motor, Flange Mount</b>												
130/260	2500/5000	20/19	5.5/5.3	590/1230	6000	200	45	42.5	3.88	2.16	1.5	N9411
<b>7 in. e-TORQ Motor, Face Mount</b>												
130/260	2500/5000	20/16	5.5/4.6	590/1040	6000	200	45	42.5	3.88	2.16	1.5	N9410
<b>14 in. e-TORQ Motor, Face Mount</b>												
130/260	1150	200	21	2700	2000	2000	200	96.1	8.22	0.119	0.09	N9430

"N" model numbers require lead time and minimum quantities.



**e-TORQ**  
Flange mount shown

# Motor Speed Controls

Our motion controls are precisely engineered to provide maximum performance from our motors and gearmotors. Choose a Bodine gearmotor and speed control and get our extended 2-year system warranty.

**2 Year**  
system warranty



## AC

### Pacesetter™ Inverter Duty Three Phase Motor Speed Controls



#### Basic Three-Phase Chassis AC Motor Speed Control

- Speed control via external speed pot or external 0-5 VDC analog signal (isolation required)
- Adjusts current limit, max. speed, min. speed, decel. time, accel. time, and slip compensation
- Output freq. selectable between 0-60 Hz and 0-120 Hz.
- Connector for remote direction control
- Connector for remote momentary start switch
- Protection against overload, overvoltage, undervoltage, and short circuit
- UL Listed, CE
- See page 43 for reference dimensions

Three-Phase AC Output Power				Input Power		Model Number
HP	Motor V	Motor Amps	Hz	V	Hz	
1/2	230	2.4	0-120	115	50 / 60	2982
1/2		2.4		230		2983
1/2		2.4		115 / 230		2984
1		4		115 / 230		2987



#### NEMA 4X/IP-65 Enclosed AC Motor Speed Control

- LED status indicators provide indication of the drive's status and operating mode
- Multi-function output relay
- Motor current selection
- More than 200% starting torque
- Undervoltage and overvoltage shuts down the drive if the AC line input voltage goes below or above the operating range
- No remote operation
- Built-in line filter for CE compliance
- cULus, CE

Three-Phase AC Output Power				Input Power		Model Number
HP	Motor V	Motor Amps	Hz	V	Hz	
1	230	3.6	0-240	115 or 208/230	50 / 60	2994



#### NEMA-1/IP-40 Enclosed AC Motor Speed Control

- Run/Fault relay output contacts turn equipment on/off and signal stop mode if a fault has occurred.
- Barrier terminal blocks facilitate wiring
- Motor overload (I<sup>2</sup>t) with RMS current limit
- Electronic inrush current limit
- Regeneration eliminates tripping due to bus overvoltage
- Overvoltage and undervoltage
- No remote operation
- Built-in line filter for CE compliance
- cULus, CE

Three-Phase AC Output Power				Input Power		Model Number
HP	Motor V	Motor Amps	Hz	V	Hz	
1	230	3.6	0-240	115 or 208/230	50 / 60	2998



#### NEMA-1 Enclosed AC Motor Speed Control

- Operates from 115-volt AC line with plug-in cord
- Trim pots adjust current limit, min. speed limit, max. speed limit, acceleration/deceleration time
- Toggle switch on front panel turns AC power on and off
- Direction switch.
- cURus

Three-Phase AC Output Power				Input Power		Model Number
HP	Motor V	Motor Amps	Hz	V	Hz	
1/2	230	2.4	0-120	115	50 / 60	2996



**Type UPM | Unfiltered SCR Motor Speed Control, NEMA-4 Enclosure**



- Operates from 115 Volt AC or 230 Volt AC line
- Designed to drive 90 Volt DC or 130 Volt DC motors
- Switchable output for 0-90 Volt DC or 0-180 Volt DC
- Back EMF feedback maintains better than 2% speed regulation

- Dip switches to easily calibrate control for different motor sizes
- NEMA 4 enclosure for wet or dirty environments
- Trim pots on PC board to adjust torque limit, minimum speed limit, maximum speed limit, acceleration time, deceleration time, and speed regulation

- Speed can be adjusted manually using speed pot on front of enclosure
- Terminal block inside enclosure for quick line and motor connection
- Line fuses inside enclosure
- Line filter inside enclosure to reduce conducted EMI
- cURus, CE, ROHS

HP Rating	Input V (VAC, 50/60 Hz)	Motor Rating (VDC)	Continuous Output Current (Amps)	Peak Output Current (Amps)	FF	Product Type	Model Number
1/5 @ 90V 1/3 @ 180V	115 / 230	90 or 130 @ 115 VAC 180 @ 230 VAC	2.1	4.2	1.4	UPM-3318E4	1865

**Type WPM | Filtered PWM DC Basic Speed Control**



- Operates from 115 Volt AC line, 50/60 Hz.
- Designed to drive 90 Volt DC or 130 Volt DC motors
- Filtered DC output for cooler motor operation, longer brush life, lower audible noise, and wider speed range

- Back EMF feedback maintains better than 2% speed regulation
- Dip switches to easily calibrate control for different motor sizes
- Two diagnostic LEDs indicate when power is on and when current output is at limit set by TORQ pot
- Five on-board user-adjustable pots for torque limit, minimum

- speed limit, maximum speed limit, acceleration time, and speed regulation
- Speed can be adjusted manually using a remote 10k speed pot (included with control)
- Connections for optional user-supplied inhibit switch
- cURus, CE, ROHS

HP Rating	Input V (VAC, 50/60 Hz)	Motor Rating (VDC)	Continuous Output Current (Amps)	Peak Output Current (Amps)	FF	Product Type	Model Number	
							1/4 in. QC tab	Terminal Block
1/4 7/16	115	90 or 130	2.0 3.2	2.5 5	1.0	WPM-2109C WPM-2137C	0780 0781	0783 0784

**Type WPM | Filtered PWM DC Basic Speed Control (Enclosed)**

- Filtered DC output
- Designed to drive 90 Volt DC or 130 Volt DC motors
- Dip switches to easily calibrate control

- Line voltage compensation minimizes speed drift
- Trim pots on PC board to adjust torque limit, minimum speed limit, maximum speed limit, acceleration time, and speed regulation

- Manual speed adjustment
- Terminal block inside enclosure
- Back EMF feedback maintains better than 2% speed regulation
- Factory installed AC line cable
- cURus, ROHS



HP Rating	Input V (VAC, 50/60 Hz)	Motor Rating (VDC)	Continuous Output Current (Amps)	Peak Output Current (Amps)	FF	Product Type	Model Number
1/4 7/16	115	90 or 130	2.0 3.2	2.5 5	1.0	WPM-2109E1 WPM-2137E1	0790 0791

For control accessories see page 35.

**Type FPM | Filtered SCR DC Basic Speed Control**



- Designed to drive 90 Volt DC or 130 Volt DC motors
- Dip switches to easily calibrate control
- Line voltage and temperature compensation
- Trim pots on PC board to adjust torque limit, minimum speed limit, maximum speed limit, acceleration time, and speed regulation.
- Back EMF feedback maintains better than 2% speed regulation
- 10k Ohm remote speed pot and 24" connecting wire supplied with each control
- Connections for optional user-supplied inhibit switch
- Terminal block
- Plug-in connector for speed pot and optional user supplied inhibit switch
- Flexibility in adding plug-in interface boards
- Built-in line and motor fuseholders (both fuses supplied)
- UR, CSA, ROHS

HP Rating	Input V (VAC, 50/60 Hz)	Motor Rating (VDC)	Continuous Output Current (Amps)	Peak Output Current (Amps)	FF	Product Type	Model Number
1/17	115	90 or 130	0.5	1	1.0	FPM-0810C	0810
1/6			1.25	2.5		FPM-0830C	0830
1/3			2.3	4.6		FPM-0850C	0850

**Type FPM | Filtered SCR DC Basic Speed Control (NEMA-12 Enclosure)**



- Designed to drive 90 Volt DC or 130 Volt DC motors
- Dip switches to easily calibrate control
- Line voltage and temperature compensation
- Trim pots on PC board to adjust torque limit, minimum speed limit, maximum speed limit, acceleration time, and speed regulation.
- Manual speed adjustment
- Terminal block inside enclosure
- Back EMF feedback maintains better than 2% speed regulation.
- Fuse holders for line and motor inside enclosure (both fuses supplied)
- UR, CSA, ROHS

HP Rating	Input V (VAC, 50/60 Hz)	Motor Rating (VDC)	Continuous Output Current (Amps)	Peak Output Current (Amps)	FF	Product Type	Model Number
<b>FPM Enclosed Filtered SCR DC Controls NEMA 12, Basic Speed Control</b>							
1/17	115	90 or 130	0.5	1	1.0	FPM-0815E	0815
1/6			1.25	2.5		FPM-0835E	0835
1/3			2.3	4.6		FPM-0855E	0855

**Type FPM | Filtered SCR DC Basic Speed and Direction Control (NEMA-12 Enclosure)**



- Filtered DC output for different motor sizes.
- Designed to drive 90 Volt DC or 130 Volt DC motors
- Line voltage and temperature compensation
- Dynamic braking for quick stops
- Trim pots on PC board to adjust torque limit, minimum speed limit, maximum speed limit, acceleration time, and speed regulation
- Manual speed adjustment
- Rotary switch on enclosure for direction
- Terminal block inside enclosure for motor connection
- Back EMF feedback maintains better than 2% speed regulation
- Fuse holders for line and motor inside enclosure (fuses included)
- UR, CSA, ROHS

HP Rating	Input V (VAC, 50/60 Hz)	Motor Rating (VDC)	Continuous Output Current (Amps)	Peak Output Current (Amps)	FF	Product Type	Model Number
<b>FPM Enclosed Filtered SCR DC Controls NEMA 12, Speed and Direction Control</b>							
1/17	115	90 or 130	0.5	1	1.0	FPM-0818E	0818
1/6			1.25	2.5		FPM-0838E	0838
1/3			2.3	4.6		FPM-0858E	0858

**Type FPM | Filtered SCR DC Remote Speed Control (NEMA-12 Enclosure)**

- Designed to drive 90 Volt DC or 130 Volt DC motors
- Dip switches to easily calibrate control
- Line voltage and temperature compensation

- Trim pots on PC board to adjust torque limit, minimum speed limit, maximum speed limit, acceleration time, and speed regulation
- Speed can be adjusted manually
- Terminal block inside enclosure

- Back EMF feedback maintains better than 2% speed regulation
- Fuse holders for line and motor inside enclosure (both fuses supplied)
- UR, CSA, ROHS



HP Rating	Input V (VAC, 50/60 Hz)	Motor Rating (VDC)	Continuous Output Current (Amps)	Peak Output Current (Amps)	FF	Remote Signal	Product Type	Model Number
<b>FPM Enclosed Filtered SCR DC Controls NEMA 12, Remote Speed Control</b>								
1/17	115	90 or 130	0.5	1	1.0	Analog	FPM-0816E	0816
1/6			1.25	2.5		Analog	FPM-0836E	0836
1/3			2.3	4.6		Analog	FPM-0856E	0856

**Type UPM | Unfiltered SCR DC Remote Speed Control**

- Designed to drive 90 Volt DC or 130 Volt DC motors
- Switchable output for 0-90 Volt DC or 0-180 Volt DC.
- Back EMF feedback maintains better than 2% speed regulation.
- Dip switches to easily calibrate control

- Two diagnostic LEDs indicate when power is on and when current output is at limit set by TORQ pot
- Six on-board user-adjustable pots for torque limit, minimum speed limit, maximum speed limit, acceleration time, deceleration time and speed regulation

- Speed can be adjusted manually using a remote 10K speed pot (included with control)
- Unfiltered drive draws lower AC line current than comparable SCR filtered controls
- Connections for optional user-supplied inhibit switch
- cURus, CE, ROHS

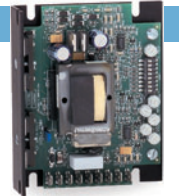

HP Rating	Input V (VAC, 50/60 Hz)	Motor Rating (VDC)	Continuous Output Current (Amps)	Peak Output Current (Amps)	FF	Product Type	Model Number	
							1/4 in. QC tab	Terminal Block
<b>UPM Unfiltered SCR DC Controls Chassis, Basic Speed Control</b>								
1/5 @ 90 V 1/3 @ 180 V	115/230	90 or 130 @ 115 VAC 180 @ 230 VAC	2.1	4.2	1.6	UPM-3318C	0865	0866

**Type UPM | NEMA-1 Unfiltered SCR Basic Speed Control (NEMA-1 Enclosure)**

- Designed to drive 90 Volt DC or 130 Volt DC motors
- Line voltage compensation minimizes speed drift
- Back EMF feedback maintains better than 2% speed regulation.
- Dip switches to easily calibrate control

- Trim pots on PC board to adjust torque limit, minimum speed limit, maximum speed limit, acceleration time, deceleration time, and speed regulation
- Two diagnostic LEDs indicate when power is on and when current output is at limit set by TORQ pot

- Manual speed adjustment
- Terminal block inside enclosure
- Unfiltered drive draws lower AC line current than comparable SCR filtered controls
- Connections for optional user-supplied inhibit switch
- cURus, ROHS



HP Rating	Input V (VAC, 50/60 Hz)	Motor Rating (VDC)	Continuous Output Current (Amps)	Peak Output Current (Amps)	FF	Product Type	Model Number
<b>UPM Enclosed Unfiltered SCR DC Controls NEMA 1, Basic Speed Control</b>							
1/5	115	90 or 130	2.1	4.2	1.6	UPM-3318E1	0867



**Type ABL | Low Voltage PWM BLDC Speed and Direction Control**

- Ideal for portable, battery operated applications
- On-board speed potentiometer for manual adjustment
- Accepts 0-5 VDC analog signal for remote operation
- Unique Smart Reverse™ circuit provides quick reversing and prevents motor plugging
- Dynamic braking for quicker stops
- 12 pulse/revolution tach output provides indication of motor speed
- Logic output indicates control shutdown due to a motor overload
- Speed can be adjusted manually or by remote control over a range of 30:1
- Inherent closed loop system maintains a 2% maximum change in motor speed from 0-100% of rated load when operated at rated speed
- cURus, ROHS

HP Rating	Input V VDC	Output V (VDC)	Continuous Output Current (Amps)	Peak Output Current (Amps)	FF	Product Type	Model Number
1/6	24-35	0-24	10	13.5	1.0	ABL-3905C	3905
1/4			15	22		ABL-3907C	3907

**Type ABL | Filtered SCR BLDC Speed and Direction Control**



- Unique Smart Reverse™ circuit for remote control of motor direction
- Dynamic braking for quicker stops
- 12 pulse/revolution tach output
- Green LED indicates AC power on
- Red LED indicates control shutdown due to a fault condition
- Speed can be adjusted manually
- DIP switches set the current limit
- Five onboard user-adjustable pots for torque limit, minimum speed limit, maximum speed limit, acceleration time, and deceleration time
- Fuse holders for line and motor fuses (fuses included)
- Inherent closed loop system maintains a 1% maximum change in motor speed from 0-100% of rated load when operated at rated speed
- UR, CSA, ROHS

HP Rating (@rpm)	Input V (VAC, 50/60 Hz)	Output V (VDC)	Continuous Output Current (Amps)	Peak Output Current (Amps)	FF	Product Type	Model Number
3/8@2500	115	0-130	3	6	1.0	ABL-3911C	3911
1/3@10,000						ABL-3921C	3921

**Type ABL | Filtered SCR BLDC Speed/Direction Control (NEMA-12 Enclosure)**



- Unique Smart Reverse™ circuit allows remote control of motor direction
- Dynamic braking for quicker stops
- 12 pulse/revolution tach output provides indication of motor speed
- Internal: Red LED indicates control shutdown due to a fault condition
- Speed can be adjusted manually
- DIP switches set the current limit
- Inherent closed loop system maintains a 1% maximum change in motor speed from 0-100% of rated load when operated at rated speed
- Fuse holders for line and motor fuses (fuses included)
- UR, CSA, ROHS

HP Rating (@rpm)	Input V (VAC, 50/60 Hz)	Output V (VDC)	Continuous Output Current (Amps)	Peak Output Current (Amps)	FF	Product Type	Model Number
3/8@2500	115	0-130*	3	6	1.0	ABL-3912E	3912
1/3@10,000						ABL-3913E	N3913

\* for brushless motors and controls

**Type ABL | Unfiltered SCR BLDC Speed and Direction Control**



- Unique Smart Reverse™ circuit
- 12 pulse/revolution tach output
- Green LED indicates AC power on
- Red LED indicates control shutdown due to a fault condition
- Speed can be adjusted manually
- DIP switches set the current limit so that the same control model can drive any size Bodine motor
- Inherent closed loop system maintains a 1% maximum change in motor speed from 0-100% of rated load when operated at rated speed
- UR, CSA, ROHS

HP Rating	Input V (VAC, 50/60 Hz)	Output V (VDC)	Continuous Output Current (Amps)	Peak Output Current (Amps)	FF	Product Type	Model Number
3/8	115	0-90	3	6	1.6	ABL-3910C	3910

"N" model numbers require lead time and minimum quantities.





# Metric Motors and Gearmotors

Our metric gearmotors and motors feature metric shafts and mounting configurations. AC metric motors are rated at 230 VAC / 50 Hz. Permanent magnet DC motors are available with voltage ratings of 180 VDC. Custom windings can be provided to match almost any international rating. We also offer a complete line of both AC and DC metric right angle and parallel shaft gearmotors.

## Parallel Shaft Gearmotors—Metric

up to 0.67 Nm | Parallel Shaft Gearmotors—Metric

A/T

- Metric mounting threads and shaft dimensions
- Three-wire winding simplifies reversing
- Impedance protected to prevent current overload (gearmotor should not be stalled when powered up)
- See page 34 for capacitors

### Fixed Speed—AC Gearmotors

Speed (rpm)	Rated Torque		Power		Rated Voltage	Freq. (Hz)	Ph	Current (Amps)	Gear Ratio	Radial Load (oz.)	Capacitor (µF/VAC)	Product Type	Model Number
	oz-in.	Nm	HP	Watts									
7	95	0.67	1/300	2.8	230	50	1	0.06	180	20	0.4/440	KCI-26T4	N1757
42	75	0.53							30			KCI-26A2	N1754
69	45	0.31							18			KCI-26A2	N1753
210	15	0.11							6			KCI-26A2	N1752

**CAPACITOR IS REQUIRED**



Type K-2A/T

up to 4.5 Nm | Parallel Shaft Gearmotors—Metric

D

- Metric mounting threads and shaft dimensions
- Unvented gearhousing for universal horizontal mounting
- Helical primary gear for quietness and hardened steel spur gearing on subsequent stages for high output torque and long life
- See pages 34 and 35 for capacitors and accessories

### Fixed Speed—AC Gearmotors

Speed (rpm)	Rated Torque		Power		Rated Voltage	Freq. (Hz)	Ph	Current (Amps)	Gear Ratio	Radial Load (lbs.)	Capacitor (µF/VAC)	Product Type	Model Number
	lb-in.	Nm	HP	Watts									
7.8	40	4.5	1/48	15	230	50	1	0.17	180	65	1.3/440	30R1BECI-D4	N1562
23	40	4.5	1/41	18				0.21	60			30R2BECI-D3	N1574
47	24	2.7	1/41	18				0.21	30			30R2BECI-D3	N1573
78	14	1.6	1/41	18				0.21	18			30R2BECI-D3	N1572
117	9.7	1.1	1/41	18				0.21	12			30R2BECI-D3	N1571

**CAPACITOR IS REQUIRED**



Type 30R-D

### Permanent Magnet DC Gearmotors

Speed (rpm)	Rated Torque		Power		Rated Voltage	Current (Amps)	Gear Ratio	Radial Load (lbs.)	Product Type	Model Number
	lb-in.	Nm	HP	Watts						
5.8	40	4.5	1/49	15	180	0.13	300	65	24A2BEPM-D5	N1398
9.6	40	4.5	1/49	15		0.13	180		24A2BEPM-D4	N1397
29	40	4.5	1/32	23		0.18	60		24A4BEPM-D3	N1395
58	23	2.0	1/32	23		0.18	30		24A4BEPM-D3	N1394
144	9.2	0.8	1/32	23		0.18	12		24A4BEPM-D3	N1392



Type 24A-D

"N" model numbers require lead time and minimum quantities.

Visit [www.bodine-electric.com](http://www.bodine-electric.com) for 2D/3D CAD drawings

# Z

## Metric—Parallel Shaft Gearmotors | up to 11.3 Nm

- Metric mounting threads and shaft dimensions
- Aluminum center ring and endshields
- Unvented gearhousing
- Industrial lip type seals on motor and output shafts
- Needle bearings on output shaft
- Permanently lubricated with high-performance lubricant
- Helical pinion accurately cut on motor shaft for maximum strength and minimum noise
- 34R-Z: die cast terminal box with terminal block included
- See page 34 for capacitors

### Fixed Speed—AC Gearmotors



Type 34R-Z

Speed (rpm)	Rated Torque		Power		Rated Voltage	Freq. (Hz)	Ph	Current (Amps)	Gear Ratio	Radial Load (lbs.)	Capacitor (µF/VAC)	Product Type	Model Number
	lb-in.	Nm	HP	Watts									
<b>Permanent Split Capacitor, Non-synchronous (TEFC)</b>													
7.8	100	11.3	1/15	50	230	50	1	0.48	180	125	5.0/370	34R4BFCEI-Z4	N1449
23	100	11.3						0.5	60	125		34R4BFCEI-Z3	N1455
70	40	4.5						0.5	20	100		34R4BFCEI-Z2	N1453
233	15	1.7						0.5	6	100		34R4BFCEI-Z2	N1451

**CAPACITOR IS REQUIRED**

### Permanent Magnet DC Gearmotors



Type 24A-Z



Type 33A-Z

Speed (rpm)	Rated Torque		Power		Rated Voltage	Current (Amps)	Gear Ratio	Radial Load (lbs.)	Product Type	Model Number
	lb-in.	Nm	HP	Watts						
<b>24A-Z PMDC Gearmotor</b>										
9.6	100	11.3	1/32	23	180	0.18	180	125	24A4BEPM-Z4	N1163
29	46	5.2					60	125	24A4BEPM-Z3	N1161
58	23	2.5					30	125	24A4BEPM-Z3	N1160
288	5	0.56					6	100	24A4BEPM-Z2	N1157
<b>33A-Z PMDC Gearmotor</b>										
29	57	6.4	1/23	32	180	0.25	60	125	33A3BEPM-Z3	N6269
58	35	3.8					30	125	33A3BEPM-Z3	N6268
144	14	1.6					12	100	33A3BEPM-Z2	N6266

# W

## Metric—Parallel Shaft Gearmotors | up to 19.8 Nm

- Metric mounting threads and shaft dimensions
- Lubricated for life
- Synthetic lubricant improves performance, and allows these gearmotors to operate in a wide temperature range
- Models with accessory shafts are ideal for mounting encoders or brakes
- 34R-W: Die cast terminal box with terminal block included
- Adaptor plate, model 0995, allows for 3-hole mounting configuration. See page 34.

### Fixed Speed—AC Gearmotors



Type 34R-W

Speed (rpm)	Rated Torque		Power		Rated Voltage	Freq. (Hz)	Ph	Current (Amps)	Gear Ratio	Radial Load (lbs.)	Capacitor (µF/VAC)	Product Type	Model Number
	lb-in.	Nm	HP	Watts									
<b>Permanent Split Capacitor, Non-synchronous</b>													
4.5	175	19.8	1/10	75	230	50	1	0.6	312.4	130	7.5/370	34R6BFCEI-W4	N1477
21	146	16.5							65.5	130		34R6BFCEI-W3	N1484
69	53	6							20.4	65		34R6BFCEI-W2	N1481
255	14	1.6							5.5	65		34R6BFCEI-W2	N1478

**CAPACITOR IS REQUIRED**

### Permanent Magnet DC Gearmotors



Type 33A-W

Speed (rpm)	Rated Torque		Power		Rated Voltage	Current (Amps)	Gear Ratio	Radial Load (lbs.)	Product Type	Model Number
	lb-in.	Nm	HP	Watts						
5.5	175	19.8	1/23	54	180	0.25	312.4	130	33A3BEPM-W4	N6247
18	147	16.6	1/14			0.41	97.5	130	33A5BEPM-W4	N6256
39	77	8.7	1/14			0.41	43.9	130	33A5BEPM-W3	N6254
85	38	4.3	1/14			0.41	20.4	65	33A5BEPM-W2	N6252
125	28	3.1	1/14			0.41	13.8	65	33A5BEPM-W2	N6251
315	10	1.1	1/14			0.41	5.48	65	33A5BEPM-W2	N6249

"N" model numbers require lead time and minimum quantities.

**Control models 1865 (see page 25) and 0865, 0866 (see page 27) are available for metric gearmotors and motors.**

- Metric mounting threads and shaft dimensions
- Unvented gearhousing
- All steel gearing
- Industrial lip type seals on motor and output shafts
- Needle bearings throughout for increased radial load capacity and long life
- Permanently lubricated
- 42R-E: Die cast terminal box with terminal block included
- *F-type only*: Hardened helical gearing for quietness and high output to size ratio
- Dual voltage (230/460V) models are also available

Fixed Speed—AC Gearmotors

Speed (rpm)	Rated Torque		Power		Rated Voltage	Freq. (Hz)	Ph	Current (Amps)	Gear Ratio	Radial Load (lbs.)	Capacitor (µF/VAC)	Product Type	Model Number
	lb-in.	Nm	HP	Watts									
140	50	5.7	1/5	140	230	50	1	1.1/.61	10	300		42R5BFPP-E2	N1665
<b>Three-phase, Non-synchronous</b>													
<b>Permanent Split Capacitor, Non-synchronous</b>													
4.7	310	35	1/7.5	100	230	50	1	0.78	300	200	7.5/370	42R5BFCI-E4	N1671
7.8	341	38.5										42R5BFCI-E4	N1669
23	297	33.6										42R5BFCI-E3	N1685
47	148	16.7										42R5BFCI-E3	N1683
70	99	11.2										42R5BFCI-E3	N1681
140	50	5.6										42R5BFCI-E2	N1680
280	26	2.9	42R5BFCI-E1	N1679									
<b>Split phase Non-synchronous (with centrifugal switch)</b>													
47	148	16.7	1/7.5	100	230	50	1	0.78	30	300		42R5BFSI-E3	N1653



Type 42R-E

Permanent Magnet DC Gearmotors

Speed (rpm)	Rated Torque		Power		Rated Voltage	Current (Amps)	Gear Ratio	Radial Load (lbs.)	Product Type	Model Number
	lb-in.	Nm	HP	Watts						
5.8	310	35	1/5	153	180	0.85	300	200	42A5BEPM-E4	N4275
29	310	35				1	60	200	42A7BEPM-E3	N4285
43	240	27				1	40	200	42A7BEPM-E3	N4284
85	120	13.6				1	20	300	42A7BEPM-E3	N4282
170	60	6.8				1	10	300	42A7BEPM-E2	N4280
170	68	7.7				1	10	300	42A7BEPM-F2	N4290
345	32	3.7	1	5	300	42A7BEPM-E1	N4279			



Type 42A-E/F

- Metric mounting threads and shaft dimensions
- Industrial lip seals on motor and output shafts
- Needle bearings on output shaft for increased radial load capacity and long life
- Permanently lubricated with high-performance lubricant
- Bronze gear for high shock load capability
- Hardened and ground worm for high strength and long life
- 34R-3F: Die cast terminal box with terminal block included

Fixed Speed—AC Gearmotors

Speed (rpm)	Rated Torque		Power		Rated Voltage	Freq. (Hz)	Ph	Current (Amps)	Gear Ratio	Radial Load (lbs.)	Capacitor (µF/VAC)	Product Type	Model Number
	lb-in.	Nm	HP	Watts									
35	37	16.7	1/15	50	230	50	1	0.5	40	40	7.5/370	34R4BFCI-3F	N1491
47	34	4.2							30	40			N1487
70	30	3.8							20	40			N1490
140	19	2.1							10	5			N1488



Type 34R-3F

Permanent Magnet DC Gearmotors

Speed (rpm)	Rated Torque		Power		Rated Voltage	Current (Amps)	Gear Ratio	Radial Load (lbs.)	Product Type	Model Number
	lb-in.	Nm	HP	Watts						
43	16	1.8	1/32	23	180	0.18	40	40	24A4BEPM-3F	N1098
86	11.6	1.4					20			N1096
172	6.4	0.76					10			N1094



Type 24A-3F

\*"N" model numbers require lead time and minimum quantities.

# Metric—Right Angle Gearmotors

**5N/5F**

Metric—Right Angle Gearmotors | up to 12.8 Nm

- Metric mounting threads and shaft dimensions
- Unvented gearhousing for universal horizontal mounting
- Bronze worm gear for high shock load capability
- Hardened and ground worm for strength and long life
- Models with accessory shafts are ideal for mounting encoders or brakes
- *AC Gearmotors:* Die cast terminal box with terminal block included
- See pages 34 and 35 for capacitors and terminal boxes

## Fixed Speed—AC Gearmotors



Type 34R-5F



Type 42R-5F and 42R-5N

Speed (rpm)	Rated Torque		Power		Rated Voltage	Freq. (Hz)	Ph	Current (Amps)	Gear Ratio	Radial Load (lbs.)	Capacitor (µF/VAC)	Product Type	Model Number
	lb-in.	Nm	HP	Watts									
<b>34R-5F Gearmotor</b>													
<i>Permanent Split Capacitor, Non-synchronous</i>													
23	72	8.1	1/15	50	230	50	1	0.5	60	50	5.0/370	34R4BFCI-5F	N1469
35	60	6.8	1/15						40	50			N1468
70	39	4.4	1/15						20	50			N1466
140	21	2.4	1/15						10	30			N1465
<b>42R-5F Gearmotor</b>													
<i>Permanent Split Capacitor, Non-synchronous</i>													
35	93	10.5	1/9	83	230	50	1	0.63	40	80	7.5/370	42R4BFCI-5F	N1627
70	60	6.8	1/9						20	80			N1624
140	32	3.6	1/9						10	10			N1623
<b>42R-5N Gearmotor</b>													
<i>Three-phase, Non-synchronous</i>													
47	109	12.3	1/5	140	230/400	50	3	1/1.61	30	180	—	42R5BFPP-5N	N1633
<i>Permanent Split Capacitor, Non-synchronous</i>													
35	113	12.8	1/7.5	100	230	50	1	0.78	40	180	7.5/370	42R5BFCI-5N	N1678
70	74	8.4							20				N1677

## Permanent Magnet DC Gearmotors



Type 33A-5F



Type 42A-5N

Speed (rpm)	Rated Torque		Power		Peak Torque (lb-in.)	Rated Voltage	Current (Amps)	Gear Ratio	Radial Load (lbs.)	Product Type	Model Number
	lb-in.	Nm	HP	Watts							
<b>33A-5F Gearmotor</b>											
43	35	5.1	1/14	54	118	180	0.41	40	80	33A5BEPM-5F	N6244
86	28	3.3			100			20			N6242
173	17	1.9			54			10			N6241
345	8.6	1			28			5			N6240
<b>42A-5N Gearmotor</b>											
43	84	9.5	1/6	121	177	180	0.85	40	120	42A5BEPM-5N	N4238
85	70	8						20			N4236
172	40	4.5						10			N4235

**5H**

Metric—Right Angle Gearmotors | up to 14.2 Nm

## Permanent Magnet DC Gearmotors



Type 42A-5H

Speed (rpm)	Rated Torque		Power		Peak Torque (lb-in.)	Rated Voltage	Current (Amps)	Gear Ratio	Radial Load (lbs.)	Product Type	Model Number
	lb-in.	Nm	HP	Watts							
36	126	14.2	1/5	141	340	180	1	48	150	42A7BEPM-5H	N4299
96	81	9.2			247			18			N4296

"N" model numbers require lead time and minimum quantities.



- Metric mounting threads and shaft dimensions
- Unvented gearhousing for universal horizontal mounting
- Hardened helical output gearing
- Bronze worm gear for high shock load capability
- Hardened and ground worm hobbled on the motor shaft for high strength and long life
- Models with accessory shafts are ideal for mounting encoders or brakes
- See pages 34 and 35 for capacitors and terminal boxes
- 42R-GB: Die cast terminal box with terminal block included

Fixed Speed—AC Gearmotors

Speed (rpm)	Rated Torque		Power		Rated Voltage	Freq. (Hz)	Ph	Current (Amps)	Gear Ratio	Radial Load (lbs.)	Capacitor (µF/VAC)	Product Type	Model Number
	lb-in.	Nm	HP	Watts									
5	380	43	1/7.5	100	230	50	1	0.78	280	200	7.5/370	42R5BFCI-GB	N1266
7.4	375	42							190				N1264
12	290	33							120				N1262
23	204	23							60				N1260



Type 42R-GB

Permanent Magnet DC Gearmotors

Speed (rpm)	Rated Torque		Power		Rated Voltage	Current (Amps)	FF	Gear Ratio	Radial Load (lbs.)	Product Type	Model Number
	lb-in.	Nm	HP	Watts							
6.2	380	42.8	1/6.7	121 / 129	180	0.85 / 0.87	1.6 / 1.0	280	200	42A5BEPM-GB	N1366
9	358	40.4						190			N1364
14.4	250	28.3						120			N1362
28.8	150	17						60			N1360



Type 42A-GB

## Metric Motors Without Gearing

- Die cast terminal box with terminal block included with 34R and 42R motors
- See page 34 for capacitors and terminal boxes

up to 140 Watts | Fixed Speed AC Induction Motors—Metric

Speed (rpm)	Rated Torque		Power		Rated Voltage	Frequency (Hz)	Ph	Current (Amps)	Radial Load (lbs.)	Capacitor (µF/VAC)	Product Type	Model Number
	(oz-in.)	(Nm)	(HP)	(Watts)								
<b>KCI-26</b>												
<b>CAPACITOR IS REQUIRED</b>												
1250	3	0.02	1/300	2.8	230	50	1	0.06	5.7	0.4/440	KCI-26	N1713
<b>30R</b>												
<b>CAPACITOR IS REQUIRED</b>												
2850	9	0.06	1/39	19	230	50	1	0.38	18	1.3/440	30R2BECI	N1319
1400	18	0.13	1/41	18				0.21				N1340
<b>34R</b>												
1400	97	0.69	1/7.5	100	230/400	50	3	.78/.45	42	No Capacitor	34R6BFPP	N1295
1400	72	0.51	1/10	75	230		1	0.6		7.5/370	34R6BFCI	N1291
<b>42R</b>												
1400	135	0.95	1/5	140	230/400	50	3	1.1/0.61	50	No Capacitor	42R5BFPP	N1273
1400	97	0.68	1/7.5	100	230		1	0.78		7.5/370	42R5BFCI	N1358



up to 200 Watts | Permanent Magnet DC Motors—Metric

Speed (rpm)	Rated Torque		Power		Rated Voltage	FF	Current (Amps)	Radial Load (lbs.)	Product Type	Model Number
	(oz-in.)	(Nm)	(HP)	(Watts)						
<b>33A (Face Mount, Base Optional)</b>										
1725	25	0.18	1/23	32	180	1.6 / 1.0	0.31	55	33A3BEPM	N6216
1725	55	0.39	1/11	70			0.62		33A5BEPM	N6227
1725	95	0.67	1/6	121			0.88		33A7BEPM	N6237
3000	55	0.39	1/6	122			0.89		33A5BEPM	N6230
3000	80	0.57	1/9	178			1.3		33A7BEPM	N6231
<b>42A (Face or Base Mount, Base Installed)</b>										
1725	95	0.68	1/6	121	180	1.6 / 1.0	0.85	90	42A5BEPM	N4227
3000	70	0.49	1/5	155			1.17		42A5BEPM	N4230
1725	120	0.85	1/5	153			1		42A7BEPM	N4237
3000	90	0.63	1/4	200			1.5		42A7BEPM	N4231



"N" model numbers require lead time and minimum quantities.

## "L" Brackets

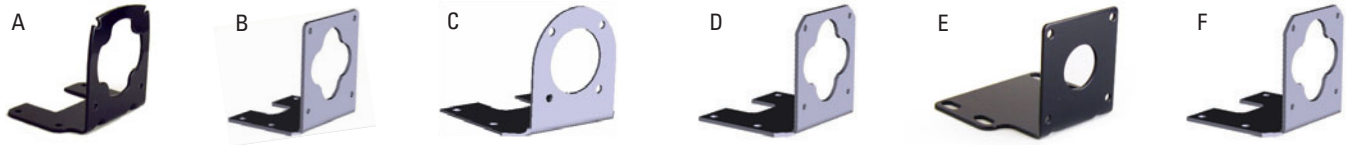

Model No.	Description
A 0969	Kit for E and F gearmotors
B 0970	Kit for WX gearmotors
C 0979	Kit for 34R and 34B motors
D 0980	Kit for 34R-Z gearmotors
E 0990	Kit for 24A motors
F 5968	Kit for 30R and 33A motors; 30R-D, 24A-D, 22B-D, 24A-Z, 33A-Z and 22B-Z gearmotors

## AC | DC Motor and Gearmotor Kits



Model No.	Description
A 0967	Base plate kit for 3F gearmotors
B 0982	Steel terminal box kit for 42R and 48R motors and gearmotors
C 0984	Die cast terminal box kit for 34R, 42R, 48R, 33A, and 42A motors and gearmotors
D 0989	Die cast rigid base for 48R-F gearmotors and all CG gearmotors
E 0992	Adaptor plate for mounting brakes or encoders for 33A/42A gearmotors/motors with accy. ready shaft extensions
F 0993	Adaptor plate for mounting brakes or encoders for 22B/34B gearmotors/motors with accy. ready shaft extensions
G 0995	3-hole adaptor plate for E, F and WX gearmotors. Provides drop-in replacement for competitive gearmotors.
H 0996	Base kit for 34R motors and gearmotors
— 1982	Die cast terminal box with terminal block for 30R motors and gearmotors
— 1984	Die cast terminal box kit with terminal block for 34R, 42R, 48R, 33A and 42A motors and gearmotors
— 5982	Die cast terminal box for 30R motors and gearmotors

## AC Capacitors

Select the appropriate run capacitor based on the capacitor specifications found on pages 4-21 (29-33 for metric models) and in the tables below. The AC gearmotor or motor nameplate states the required capacitance of the run capacitor, but it is also critical to specify a capacitor that has the voltage ratings as shown in these tables. When using a run capacitor that is not supplied by Bodine Electric, please make sure the voltage rating is equal to or higher than the voltage rating specified on this page. Different motor sizes might require a different minimum voltage rating for the run capacitor.

Box-Type Metalized Film Capacitors (Plastic Case)

Part Number	µF /VAC	Part Number	µF /VAC	Part Number	µF /VAC
49400045 <sup>1</sup>	0.9/250	49401049	0.4/440	49401115 <sup>1</sup>	6.0/450
49400046 <sup>1</sup>	1.0/250	49400091	1.3/440	49401106	9.0/250
49400047 <sup>1</sup>	1.2/250	49401047	2.3/250	49401006	12.5/250
49400048 <sup>1</sup>	1.3/250	49426812 <sup>1</sup>	4.0/250	49401016	15.0/250
49400050 <sup>1</sup>	1.5/250	49401015	5.0/250	49401113 <sup>1</sup>	20.0/250
49400051 <sup>1</sup>	1.6/250	49401002 <sup>1</sup>	7.5/370	49401112 <sup>1</sup>	27.5/250
		49401054	10.0/250	49401090 <sup>1</sup>	30.0/250

Ratings in table below are for Alternate Box-Type (plastic) capacitors

Alternate Box-Type (Plastic) Part Number	µF /VAC	Metal Can-Type Capacitor Part Number <sup>3</sup>
49401123 (low-cost) <sup>1</sup>	3.75/370	49400028
49401068 (low-cost) <sup>1</sup>	5.0/400	49400029
49401007 (low-cost) <sup>1</sup>	10.0/370	49400032
49401107 (low-cost) <sup>1</sup>	12.5/370	49400033
49401075 (low-cost) <sup>1</sup>	15.0/350	49400034
49401057 (low-cost)	20.0/350	49400035
49401124 (round, metal case) <sup>2</sup>	25.0/370	49428281

1. The capacitor fits inside a Bodine model number 0984 terminal box kit.
2. Capacitor 49401124 has a round case. It requires a mounting clamp, model 54701013.
3. Metal can-type capacitors will be phased out and are only available while supply lasts. Please use our low cost alternative numbers instead.

For mounting details and dimensions, visit [www.bodine-electric.com](http://www.bodine-electric.com)



Model No.	Static Torque (lb-in.)	Volt AC	Ohms	Wt. (oz.)
0997	15	120	1067	11

This item is intended only for 33A and 42A PMDC motors and gearmotors.

Control Accessories

BLDC  
PMDc

Item	Model No.	Description
—	0888	<b>Analog Interface Board</b> for use with model 0810, 0830, and 0850 controls. Allows control to accept a variable voltage or current signal from user's host controller to automatically control motor speed. Inputs are optically isolated.
—	0890	<b>Electronic Direction and Braking Board, F-B-R Kit</b> , for use with model 0810, 0830, and 0850 controls. Allows user to change motor direction and to dynamically brake motor to a quick stop. Inputs are not optically isolated. This kit includes one F-B-R board, one cable and connector, mounting hardware, and two additional braking resistors.
—	0893	<b>Local/Remote Switch</b> for use with model 0810, 0830, and 0850 controls when used with accessory model 0888. Allows user to switch between automatic and manual operation.
—	0895	<b>Switch Sealing Kit</b> upgrades NEMA-12 brushless DC and PMDC enclosed controls to IP-44 rating.
A	3981	<b>Cable Kit</b> for stock 34B/FV INTEGRAMotors. Length: six feet (3 cables: power, logic and encoder).
B	3982	<b>Extension Cable</b> for model 3910, 3911, 3921 and 3912 controls. Extends the cable between the motor and control by six feet. Both ends are equipped with circular connections for easy connection between model 3983 cable assembly or encased control and the motor. Length: six feet.
C	3983	<b>Connection Cable Assembly</b> for connecting model 3910, 3921 and 3911 chassis controls to stock 130 V motors. One end of the cable is equipped with a circular connector, the other end is equipped with quick disconnects for phase leads, and a molded connector for the commutation leads. Length: 6 feet.
D	3984	<b>Analog Interface And Isolation Module</b> for model 3910, 3911, 3921 and 3912 controls. Provides Analog interface and isolates controls from system controller input signals which may be at different potentials.
—	43300260	<b>Speed Potentiometer Kit</b> for use with FPM controls. Contains 10k Ohm potentiometer, hardware, wire and connector for manually regulating motor speed.
—	43300270	<b>Fuse and Speed Potentiometer Kit</b> for use with model 3910 control. Contains potentiometer for manually regulating motor speed and various fuses to cover the range of motors and gearmotors which can be used with the control.



Metric Accessories

Metric "L" Brackets

AC | DC



Item	Model No.	Description
A	0990	Metric Kit for 24A
B	1968	Metric Kit for 33A motors, and type D and Z gearmotors
C	1970	Metric Kit for type W gearmotors
D	1969	Metric Kit for type E and F gearmotors
—	—	no "L" bracket kits are available for 34R and 34R-Z gearmotors

Metric Motor and Gearmotor Kits

AC | DC



Item	Model No.	Description
A	1982	Metric die cast terminal box kit for 30R motors and gearmotors
A	1984	Metric die cast terminal kit with terminal block for 33A, 34R, 42A and 42R motors and gearmotors
B	0991	Metric die cast base kit for 42A motors and gearmotors
—	0992	Metric adaptor plate for 33A and 42A motors and gearmotors

# Reference Drawings and Dimensions

## Parallel Shaft Gearmotor Dimensions

Dimensions (in inches) are for reference only. For CAD drawings and up-to-date specifications, please visit [www.bodine-electric.com](http://www.bodine-electric.com).

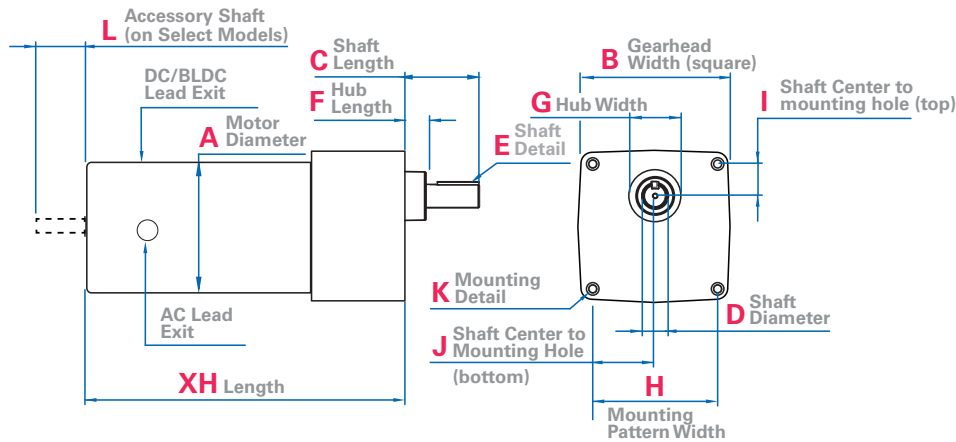

**Gearhead Type D, Z, WX, E/F, pages 5-9**

	Product Type	Wt. (lbs.)	XH Length	A Diameter (Height)	B Width (square)	C Shaft Length	D Shaft Diameter	E Shaft Detail	F Hub Length	G Hub Width	H Mounting Pattern Width	I Shaft Center to Mounting Hole (top)	J Shaft Center to Mounting Hole (bottom)	K Mounting Detail	L Acc'y Shaft	Cord/Lead Length (in.)												
<b>Type D Gearmotor</b>																												
24A-D	24A2-D	4.0	5.887	2.42	3.42	1.56	.500	Flat	.554	1.125	2.652	.582	1.326	[4]10-32 UNF-2B x .38 deep on a 3.75 B.C.	Yes	24												
	24A4-D	4.5	6.637												Yes	24												
22B-D	22B2-D	3.75	5.522	2.378											Yes	12/24												
22B-D INTEGRA	22B2-D	5.4	6.631	2.93											No	None												
<b>Type Z Gearmotor</b>																												
34R-Z	34R4-Z4/3	9.3	8.328	4.02	3.40	1.56	.500	Flat/Key	.29	1.125	2.652	.582	1.326	[4]10-32 UNF-2B x .38 deep on a 3.75 B.C.	No	12												
	34R6-Z4/3		8.345																									
	34R4-Z2		7.428																									
	34R6-Z2		7.445																									
24A-Z	24A4-Z2	5.0	6.890	2.42	3.42	1.56	.500	Flat/Key	.29	1.125	2.652	.582	1.326	[4]10-32 UNF-2B x .38 deep on a 3.75 B.C.	Yes	24												
	24A4-Z3/Z4		7.790																									
33A-Z	33A3-Z2	5.8	6.895	3.39													3.42	1.56	.500	Flat/Key	.29	1.125	2.652	.582	1.326	[4]10-32 UNF-2B x .46 deep on a 3.75 B.C.	No	None
	33A3-Z3		7.795																									
22B-Z	22B3-Z2	5.25	6.326	2.378	3.42	1.56	.500	Flat/Key	.29	1.125	2.652	.582	1.326	[4]10-32 UNF-2B x .46 deep on a 3.75 B.C.	Yes	12/24												
	22B2-Z4	4.75	6.746												No													
	22B3-Z4	5.25	7.226												Yes													
22B-Z INTEGRA	22B3-Z2	5.3	7.435	2.93											3.42	1.56	.500	Flat/Key	.29	1.125	2.652	.582	1.326	[4]10-32 UNF-2B x .46 deep on a 3.75 B.C.	No	None		
	22B3-Z3	5.3	8.335																									
	22B2-Z4	4.8	7.885																									
<b>Type WX Gearmotor</b>																												
34R-WX	34R6-WX	12.0	8.956	4.02	4.06	2.0	.625	Key	.56	1.31	3.375	.863	1.688	[4]1/4 -28 UNF-2B x .50 deep on a 4.78 B.C.	No	12												
33A-WX	33A5-WX	9.7	8.665	3.385											Yes	24												
34B-WX	34B3-WX	4.8	6.473	4.02											Yes	12/24												
<b>Type E/F Gearmotor</b>																												
34R-E	34R4-E	11.0	8.112	4.02	4.64	2.0	.750	Key	.37	1.536	3.625	.913	1.813	[4]1/4 -28 UNF-2B x .50 deep on a 4.78 B.C.	No	12												
42R-E	42R3-E	12.0	8.065	4.73																								
	42R5-E	14.5	9.128	4.73																								
48R-F	48R6-F	26.0	10.487	5.90													No	24										
42A-E/F	42A3-E	12.7	8.197	4.26															Yes	24								
	42A5-E	14.9	9.323																									
	42A7-E	18.1	10.448																									
33A-E/F	33A3-E	8.7	8.004	3.39													Yes	24										
	33A5-E	10.5	9.064																									
	33A7-E	11.9	10.265																									
34B6-E	34B3-E	11.0	6.629	4.02															No	12/24								
	34B4-E	12.0	7.129																									
	34B6-E	14.0	8.129																									

Only the first four characters of the product type are relevant to dimensions



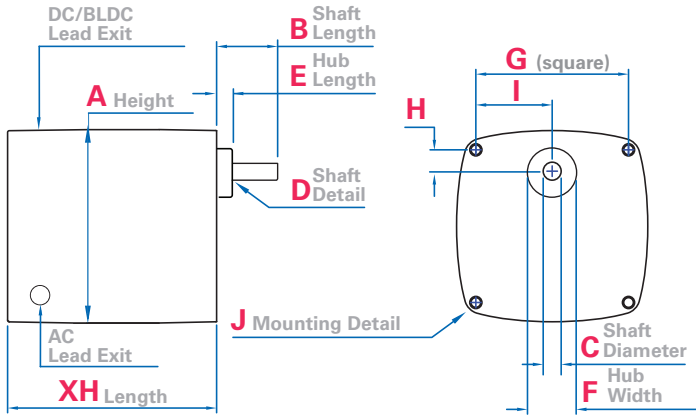

**Gearhead Type K-2A/T, 30R-D, pages 4-5**

	Product Type	Wt. (lbs.)	XH Length (square)	A Height (square)	B Shaft Length	C Shaft Diameter	D Shaft Detail	E Hub Length	F Hub Width	G Mounting Pattern Width	H Shaft Center to Mounting Hole	I Shaft Center to Mounting Hole	J Mounting Detail	Lead/Cord Length (in.)
<b>Type K-2 Gearmotor</b>														
K-2T	22	2.2	2.539	2.38	1.00	.250	Flat	.255	.52	1.900	.356	.950	[2]8-32 UNC-2A	12
	23	2.4	2.664											
	24	2.7	3.023											
K-2A	23	2.3	2.507	2.38	1.00	.250	Flat	.255	.52	1.900	.356	.950	[2]8-32 UNC-2A	12
	24	2.6	2.866											
<b>Type 30R-D Gearmotor</b>														
30R-D	30R1	5.8	5.242	3.45	1.56	.500	Flat	.554	1.125	2.652	.582	1.326	[4]10-32 UNF-2B x .38 deep Max.	12
	30R2	6.3	5.492											
	30R4	7.5	6.000											

Only the first four characters of the product type are relevant to dimensions

**Gearhead Type HG, page 10**

	Product Type	Weight (lbs.)	XH Length	A Diameter	B Height	C Acc'y Shaft	Lead/Cord Length (in.)
42R-HG	42R6-HG	9.5	9.855	4.73	9.85	No	12
33A-HG	33A7-HG	10.5	10.547	3.39	9.80	Yes	24

Only the first four characters of the product type are relevant to dimensions

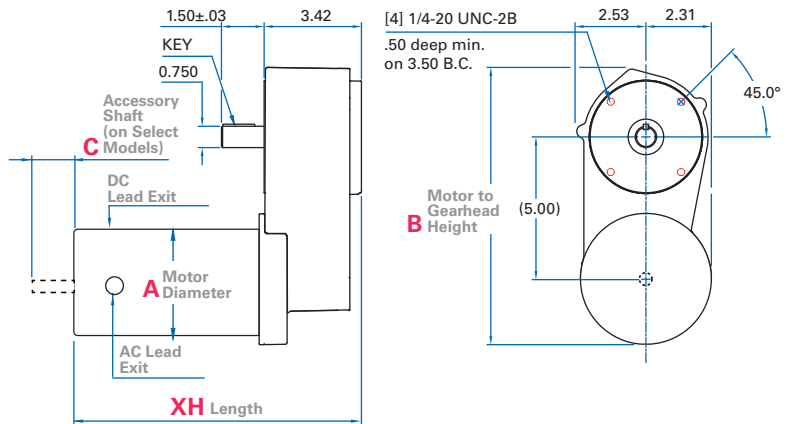

**Gearhead Type CG, page 11**

	Product Type	Weight (lbs.)	XH Length	A Diameter	B Acc'y Shaft	Lead/Cord Length (in.)
48R-CG	48R6-CG	34	12.849	5.917	No	12
42A-CG	42A7-CG	29	12.07	4.262	Yes	24

Only the first four characters of the product type are relevant to dimensions

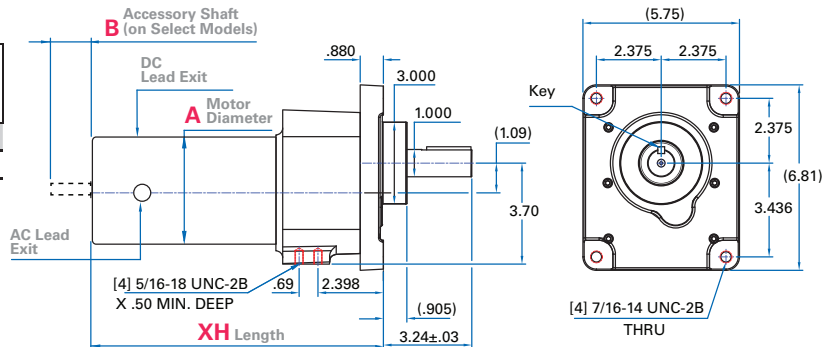

# Right Angle Gearmotor Dimensions

Dimensions (in inches) are for reference only. For CAD drawings and up-to-date specifications, please visit [www.bodine-electric.com](http://www.bodine-electric.com).

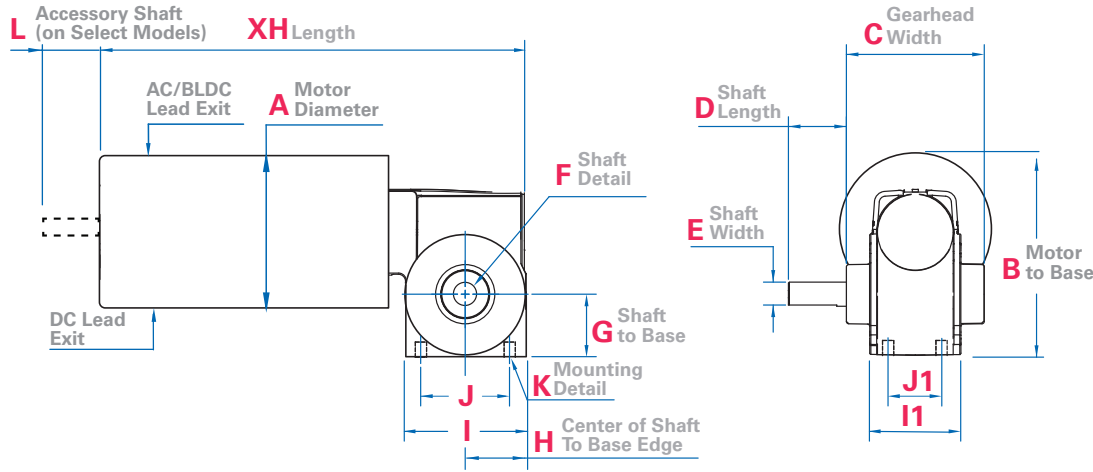

**Gearhead Type 3 N/3F, pages 12-13 (Mounts from Gearhead)**

	Weight (lbs.)	XH Length	A Dia-meter	B Motor to Base	C Gearhead Width	D Shaft Length	E Shaft Width	F Shaft Detail	G Shaft to Base	H	I Base Length	I1 Base Width	J Mounting Hole Length	J1 Mounting Hole Width	K Mounting Detail	L Acc'y Shaft	Cord/Lead Length (in.)
30R4-3N	7.5	7.192	3.34	4.30	2.871	1.00	.500	Flat	1.28	1.28	2.56	2.111	2.00	1.188	[4] 1/4 -20 UNF-2B x .50 deep	No	12
34R4-3F	9.3	8.61	4.02	4.37												No	12
24A4-3F	5.3	7.422	2.42	3.57												Yes	24
22B4-3F	5.4	7.677	2.378	3.80												No	12/24
22B4-3F INTEGRA	5.4	8.79	2.93	3.82												No	None

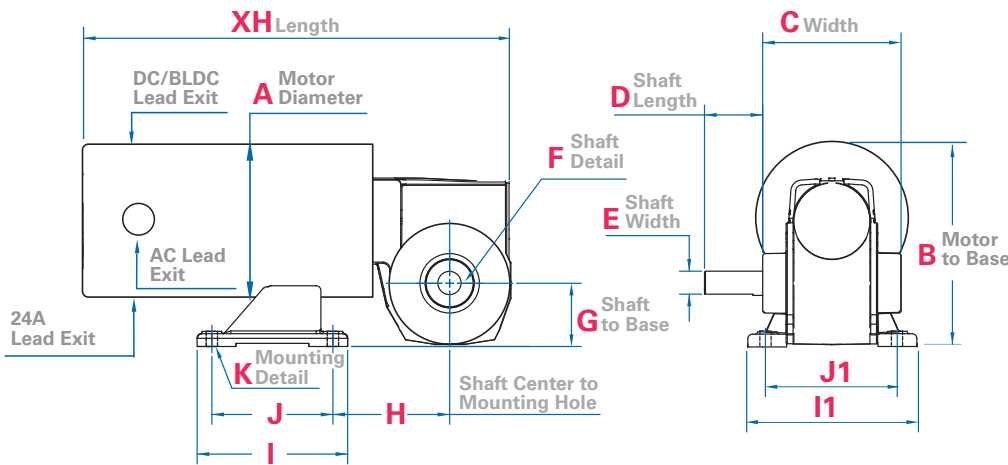

**Gearhead Type 3F, 5R/5L, pages 12-13 (Mounts from Motor)**

	Weight (lbs.)	XH Length	A Dia-meter	B Motor to Base	C Width	D Shaft Length	E Shaft Width	F Shaft Detail	G Shaft to Base	H Shaft Center To Mounting Hole	I Base Length	I1 Base Width	J Mounting Hole Length	J1 Mounting Hole Width	K Mounting Detail	Cord/Lead Length (in.)
<b>Type 3F Gearmotor</b>																
24A4-3F	5.3	7.422	2.42	3.57	2.871	1.00	.500	Flat	1.28	3.14	2.50	3.62	1.25	2.94	[4] ø.28	24
<b>Type 5R Gearmotor</b>																
34R4-5R	11.5	9.206	4.02	5.24	3.568	1.50	.625	Key/Flat	1.63	3.01	3.88	4.38	3.12	3.38	[4] ø.29	12
33A3-5R	9.0	8.651	3.39	4.92												24
<b>Type 5L Gearmotor</b>																
42R4-5L	13.5	9.54	4.73	5.57	3.568	1.50	.625	Key/Flat	1.56	2.856	4.38	5.02	3.62	4.00	[4] ø.30	12
42A4-5L	14.1	9.635	4.26	5.54												24

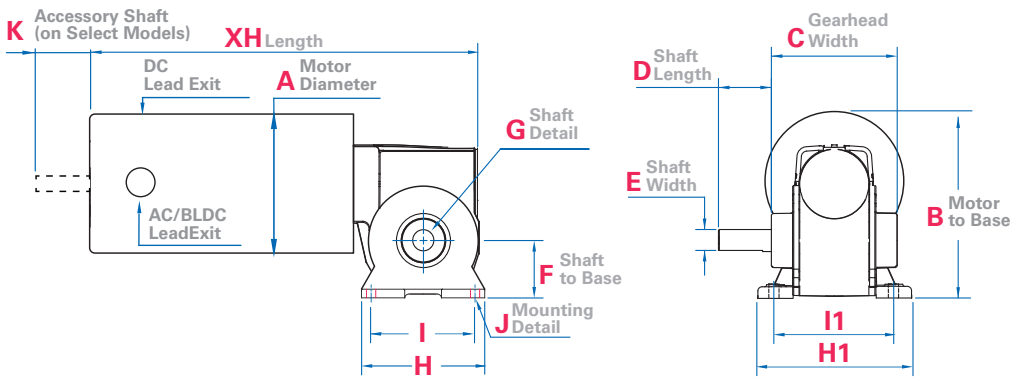

**Gearmotor Type 5N, 5F, 5H, pages 14-16 (Mounts from Gearhead with Feet)**

	Product Type	Wt. (lbs.)	XH Length	A Dia-meter	B Motor to Base	C Gearhead Width	D Shaft Length	E Shaft Width	F Shaft to Base	G Shaft Detail	H Base Length	H1 Base Width	I Mounting Hole Length	I1 Mounting Hole Width	J Mounting Detail	K Acc'y Shaft	Cord/Lead Length (in.)																
<b>Type 5N Gearmotor</b>																																	
42R-5N	42R5-5N	15.5	10.103	4.73	5.64	3.568	1.50	.625	1.67	Key/Flat	3.56	3.81	3.00	3.25	[4]ø .271/.266 Holes	No	12																
	42R6-5N	17.5	10.540													Yes	24																
42A-5N	42A5-5N	14.3	10.198	4.62	5.40											4.02	5.26	No	Yes	12	No	Yes	24										
	34B3-5N	9.0	7.723	3.568	1.50																			.625	1.67	Key/Flat	3.56	3.81	3.00	3.25	[4]ø .271/.266 Holes	No	12
	34B4-5N	10.0	8.223																													Yes	24
34B6-5N	12.0	9.233	Yes	24																													
<b>Type 5F Gearmotor</b>																																	
34R-5F	34R6-5F	12.0	10.206	4.02	5.28											3.568	1.50	.625	1.67	Key/Flat	3.56	3.81	3.00	3.25	[4]ø .271/.266 Holes	No	12						
33A-5F	33A5B-5F	9.9	9.711	3.39	4.96																					No	Yes	24					
	33A5F-5F	9.9	9.701																										Yes	24			
<b>Type 5H Gearmotor</b>																																	
48R-5H	48R6-5H	40.0	12.928	5.90	8.07	4.723	2.38	.750	3.000	Key	5.62	6.263	3.875	5.373	[4]ø .41/.44 Holes	No	12																
42A-5H	42A7-5H	24.4	12.947	4.26	7.25											Yes	24																

Only the first four characters of the product type are relevant to dimensions

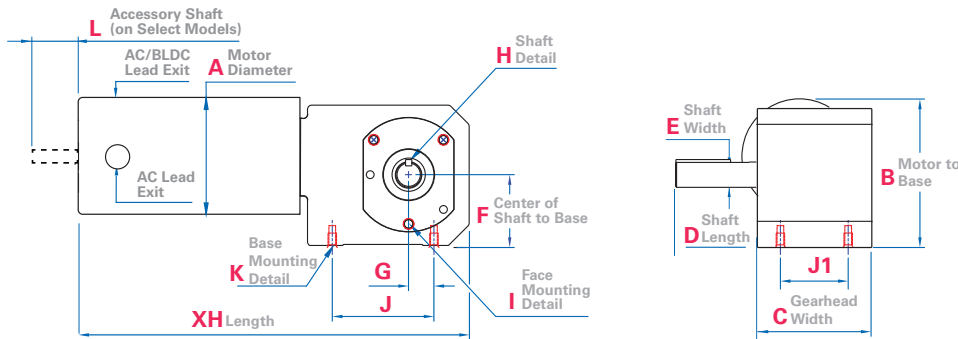

**Gearhead Type 3RD, GB, pages 16-17**

	Product Type	Wt. (lbs.)	XH Length	A Dia-meter	B Motor to Base	C Gear-head Width	D Shaft Length	E Shaft Width	F Shaft to Base	G Shaft to Mounting Hole Center	H Shaft Detail	I Face Mounting Detail	J Mounting Hole Length	J1 Mounting Hole Width	K Base Mounting Detail	N Acc'y Shaft	Cord/Lead Length (in.)										
<b>Type 3RD Gearmotor</b>																											
30R-3RD	30R2	9.0	8.140	3.36	4.812	3.60	1.50	.500	1.562	.625	Flat	[4]10-32 UNF-2B x .31 Deep Min.	2.000	2.50	[4]1/4 -20 UNF-2B .31 deep	No	12										
	30R4	10.5	8.640													Yes	24										
24A-3RD	24R2	9.0	8.07	2.42	4.147											No	Yes	12									
24R4	10.5	8.82	Yes																24								
22B-3RD	22B2	6.5	8.085	2.378	4.377											No	Yes	12									
	22B4	6.5	9.045																Yes	24							
<b>Type GB Gearmotor</b>																											
42R-GB	42R5	17.5	11.458	4.73	5.06											3.335	2.38	.750	2.150	.75	Key	[4] 5/16 -18 UNF-2B x .50 Deep Max. on 2.913 B.C.	3.00	2.00	[4]1/4 -20 UNF-2B .40 Deep Min.	No	12
	42R6	19.5	11.893																							Yes	24
33A-GB	33A5	13.6	11.067	3.39	4.38												2.362	.748	2.150	.75	Key	[4] 5/16 -18 UNF-2B x .50 Deep Max. on 2.913 B.C.	3.00	2.00	[4] M6 X 1-6H .45 Deep Max.	No	24
	33A7	14.9	12.268			Yes	24																				
42A-GB	42A5	18.0	11.554	4.26	4.82	2.38	.750	2.150	.75	Key	[4] 5/16 -18 UNF-2B x .50 Deep Max. on 2.913 B.C.	3.00	2.00	[4]1/4 -20 UNF-2B .45 Deep Min.	Yes		24										

Only the first four characters of the product type are relevant to dimensions

# Hollow Shaft Gearmotor Dimensions

Dimensions (in inches) are for reference only. For CAD drawings and up-to-date specifications, please visit [www.bodine-electric.com](http://www.bodine-electric.com).

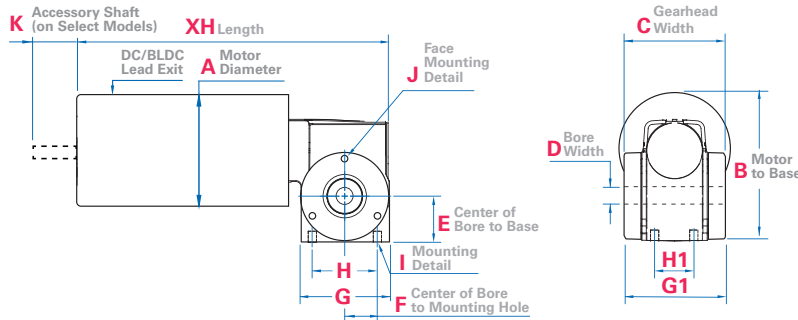

**Gearhead Type 3F/H, pages 12-13 (Mounts from Gearhead)**

	Wt. (lbs.)	XH Length	A Diameter	B Motor to Base	C Gearhead Width	D Bore Width	E Bore to Base	F Bore to Mtg. Hole	G Base Length	G1 Base Width	H Mounting Hole Length	H1 Mounting Hole Width	I Mounting Detail	J Face Mount Detail	K Acc'y Shaft	Cord/Lead Length (in.)
24A4-3F/H	5.3	7.422	2.42	3.57	3.085	.502	1.280	1.000	2.56	3.085	2.00	1.188	[4] 1/4 -20 UNF-2B x .50 Deep Max.	[3] 10-32 UNF-2B .35 Min. Deep on 2.125 B.C.	Yes	24
22B4-3F/H	5.4	7.677	2.378	3.80											No	12
22B4-3F/H INTEGRA	5.4	8.79	2.93	3.823											No	None

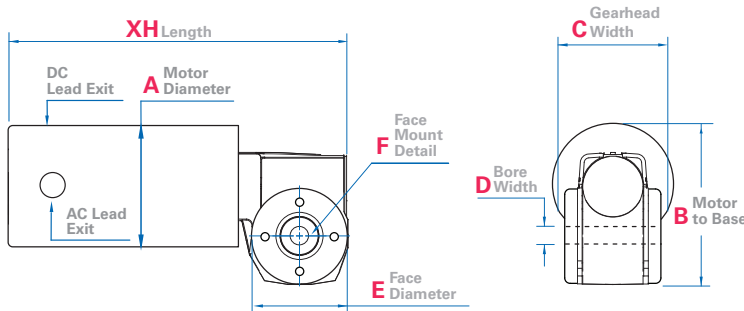

**Gearhead Type 5L/H, page 14 (Face Mount)**

	Product Type	Weight (lbs.)	XH Length	A Diameter	B Motor to Base	C Gearhead Width	D Bore Width	E Face Diameter	F Face Mount Detail	Lead/Cord Length (in.)
33A-5L/H	33A5		9.711	3.39	5.04	2.740	.627	3.50	[4] 1/4-20 UNF-2B x .44 Min. Deep on 2.375 B.C.	24
42R-5L/H	42R6		10.540	4.73	5.71					None

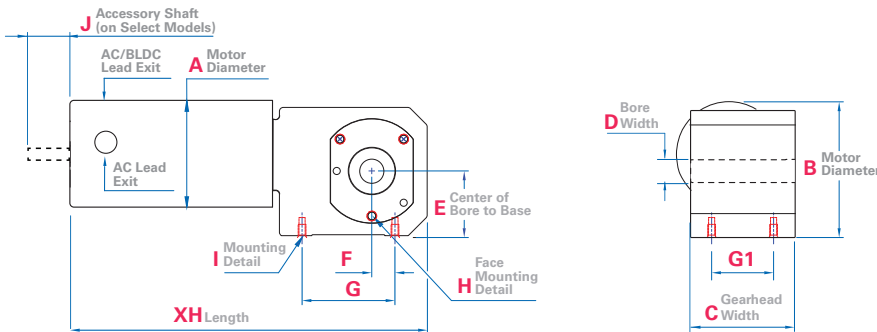

**Type GB/H, page 17 (Face Mount)**

	Product Type	Wt. (lbs.)	XH Length	A Diameter	B Motor to Base	C Gearhead Width	D Bore Width	E Bore to Base	F	G Mounting Hole Length	G1 Mounting Hole Width	H Face Mounting Detail	I Mounting Detail	J Acc'y Shaft	Lead/Cord Length (in.)
42R-GB/H	42R5	17.5	11.456	4.73	5.06	3.335	.752	2.150	.75	3.00	2.00	[3] 5/16-18 UNF-2B x .44 Max. Deep on 2.913 B.C.	[4] 1/4-20 UNF-2B x .40 Min. Deep	No	12
	42R6	19.5	11.893											No	24
33A-GB/H	33A5	13.6	11.067	3.39	4.38	3.335	.752	2.150	.75	3.00	2.00	[3] 5/16-18 UNF-2B x .44 Max. Deep on 2.913 B.C.	[4] 1/4-20 UNF-2B x .40 Min. Deep	No	24
42A-GB/H	42A5	19.5	11.554	4.26	4.82									Yes	24

Only the first four characters of the product type are relevant to dimensions



# Motor Dimensions

Dimensions (in inches) are for reference only. For CAD drawings and up-to-date specifications, please visit [www.bodine-electric.com](http://www.bodine-electric.com).

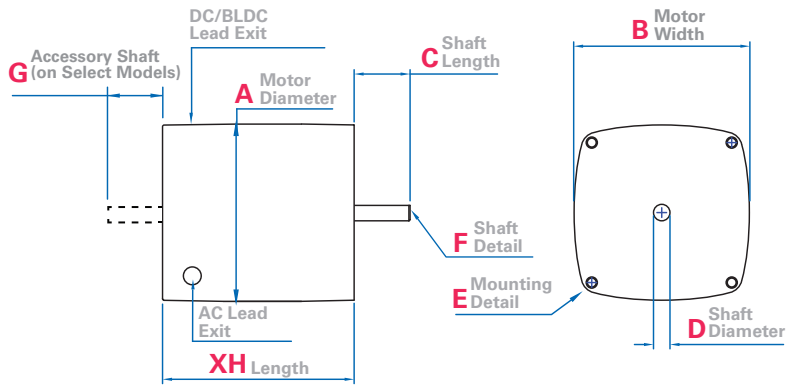

## Motor Type K-2, 30R, 22B, pages 18-19, 23

	Product Type	Weight (lbs.)	XH Length	A Diameter Square	B Width	C Shaft Length	D Shaft Diameter	E Mounting Detail	F Shaft Detail	G Acc'y Shaft	Lead/Cord Length (in.)
K-2	K2-23	1.6	1.827	2.38	2.38	.62	.188	[4] 8-32 UNC-2B x .18 Deep Max. on 2.687 B.C.	Flat	No	12
	K2-24	1.9	2.20								
	K2-26	2.2	2.50								
K-2 Torque Motor	Model 0621	2.2	2.484								
30R	30R2	4.75	3.665	3.53	3.34	1.06	.313	[4]10-32 UNF-2B x .32 deep Max. on 3.75 B.C.	Flat	Yes	24
	30R4										
30R Torque Motor	Model 5625										
22B	22B2	2.5	3.610	2.633	2.378	.94	.375	[4] 8-32 UNC-2B x .35 Deep Max. on 2.625 B.C.	Flat	Yes	12/24
	22B4	3.5	4.570							No	None
22B INTEGRA	22B2	2.5	4.719	2.93	2.93						
	22B4	3.5	5.679								

Only the first four characters of the product type are relevant to dimensions

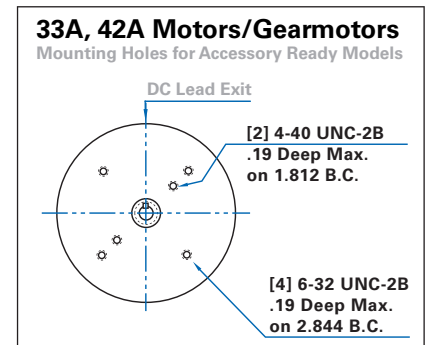
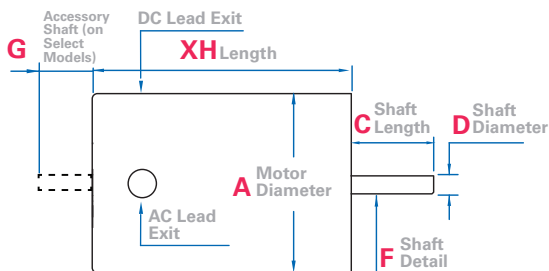

## Motor Type 34R, 42R, 33A, 42A, 34B, pages 19-23 (Face Mount)

	Product Type	Weight	XH Length	A Diameter	B Width (PMDC)	C Shaft Length	D Shaft Diameter	E Mounting Detail	F Shaft Detail	G Acc'y Shaft	Lead/Cord Length (in.)
34R	34R4	9.0	5.526	4.02	—	1.25	.375	[4] 1/4-20 UNC-2B x .31 Min. Deep on 2.75 B.C.	Flat	No	12
	34R6		6.526								
42R	42R3	7.75	5.616	4.73	—	1.38	.375	[4] 1/4-20 UNC-2B x .31 Min. Deep on 3.75 B.C.	Flat	No	12
	42R5	11.0	6.679								
33A	33A3	5.1	5.140	3.39	3.75	1.48	.375	[4] 10-32 UNF-2B x .25 Min. Deep on 2.75 B.C.	Flat	Yes	24
	33A5	6.28	6.200	3.39	3.75	1.48	.500				
	33A7	7.45	7.401								
42A NEMA 42C	42A5	11.3	6.656	4.26	4.25	1.62	.500	[4] 1/4-20 UNC-2B x .31 Min. Deep on 3.75 B.C.	Flat	Yes	24
	42A7	14.5	7.781			1.31			Flat/Key		
42A NEMA 42CZ	42A5	11.3	6.656								
	42A7	14.5	7.781								
34B	34B3	6.0	4.043	4.02	—	1.625	.500	[4] 1/4-20 UNC-2B x .31 Min. Deep on 2.75 B.C.	Flat	Yes	12/24
	34B4	7.0	4.543								
	34B6	9.0	5.543								

Only the first four characters of the product type are relevant to dimensions

# Motor Dimensions

Dimensions (in inches) are for reference only. For CAD drawings and up-to-date specifications, please visit [www.bodine-electric.com](http://www.bodine-electric.com).

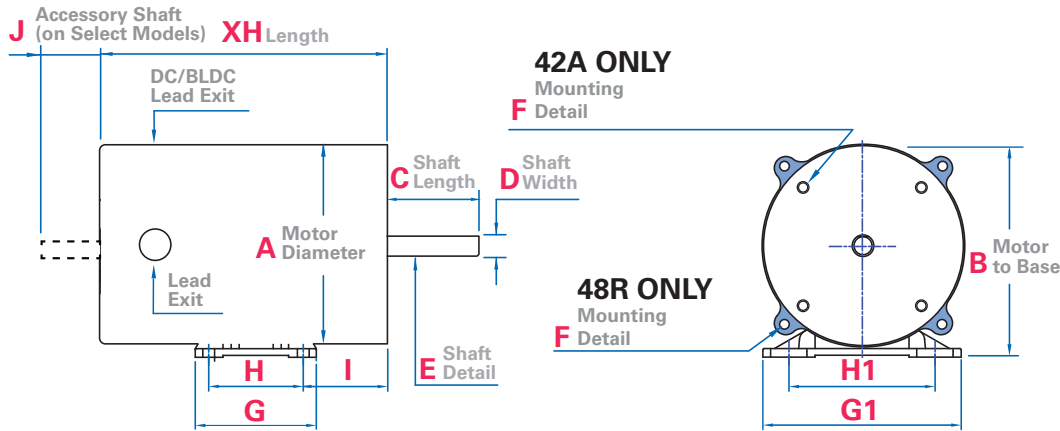

Motor Type 42R, 48R, 42A, pages 18-22 (Base Mount)

	Product Type	Weight (lbs.)	XH Length	A Diameter	B Motor to Base	C Shaft Length	D Shaft Width	E Shaft Detail	F Face Mount Detail	G Base Length	G1 Base Width	H Mtg. Hole Length	H1 Mtg. Hole Width	I Base Mtg. to Face	J Acc'y Shaft	Lead/Cord Length (in.)
42R	42R3	7.8	5.616	4.73	4.999	1.38	.375	Flat	Base mount 42R motors have no face mounting holes	2.88	4.75	2.25	3.50	1.572	None	12
	42R5	11	6.679													
	42R6	13	7.116													
42R Torque Motor	Model 2628	12.5	6.201	4.62	4.93	1.31	.375	Flat	[4] 1/4-20 UNC-2B x .31 Max. Deep on 3.75 B.C.	2.88	4.75	2.25	3.50	1.569	1.56	12
48R	48R5	17.0	7.329	5.90	5.85	2.06	.625	Key	[4] 3/8-16 UNC-2B x .50 Max. Deep on 5.875 B.C.	3.50	5.75	2.75	4.25	1.446	None	12
	48R6	20.0	7.797													
48R Torque Motor	Model 0632	20.5	6.676	5.73	5.85	2.06	.625	Key	[4] 3/8-16 UNC-2B x .50 Max. Deep on 5.875 B.C.	3.50	5.75	2.75	4.25	1.446	2.00	12
42A	42A5	11.3	6.656	4.26	4.77	1.62	.500	Flat	[4] 1/4-20 UNC-2B x .31 Max. Deep on 3.75 B.C.	2.88	4.75	2.25	3.50	1.471	1.28	24
	42A7	14.5	7.781													

Only the first four characters of the product type are relevant to dimensions

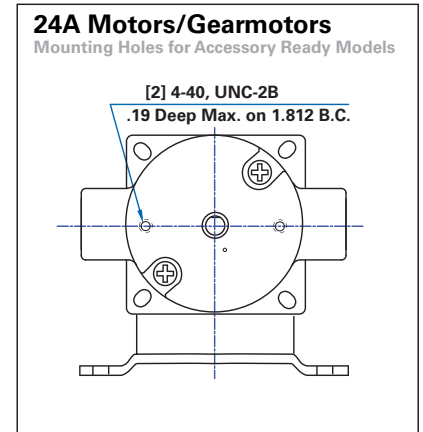
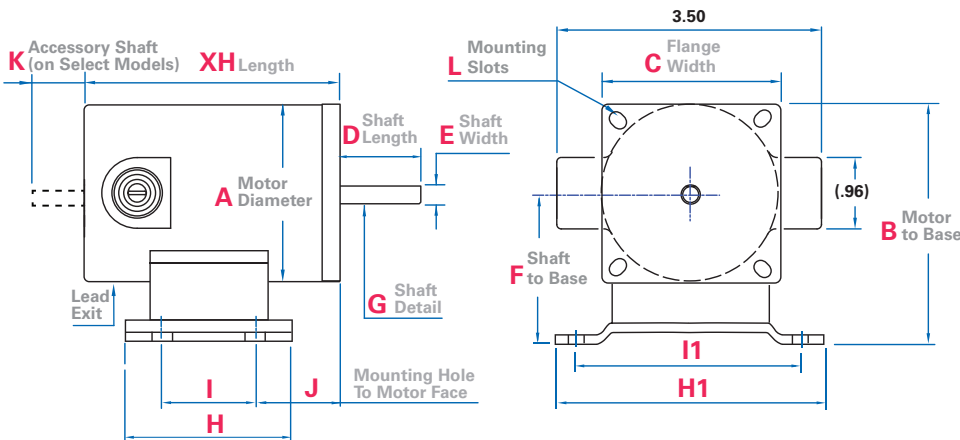

Motor Type 24A, page 22 (Base/Flange Mount)

	Product Type	Wt. (lbs.)	XH Length	A Diameter	B Motor to Base	C Flange Width	D Shaft Length	E Shaft Width	F Shaft to Base	G Shaft Detail	H Base Length	H1 Base Width	I Base Mounting Hole Length	I1 Base Mounting Hole Width	J	K Acc'y Shaft	L Mounting Slots	Lead/Cord Length (in.)
24A	24A0	2.0	3.240	2.42	3.185	2.41	.94	0.312	1.98	Flat	2.25	3.62	1.25	3.00	.625	Yes	1.81W x 2.445L on 2.764 B.C.	24
	24A2	2.5	3.870												1.62			
	24A4	3.0	4.620												1.81			

Only the first four characters of the product type are relevant to dimensions

## e-TORQ Dimensions

Dimensions (in inches) are for reference only. For CAD drawings and up-to-date specifications, please visit [www.bodine-electric.com](http://www.bodine-electric.com).

Flange Mount, page 23

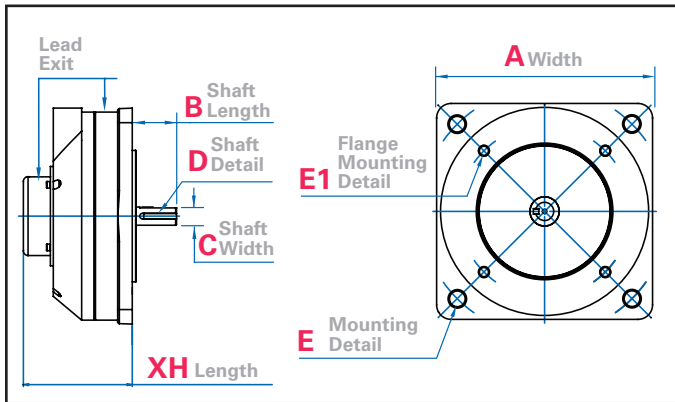

Face Mount, page 23

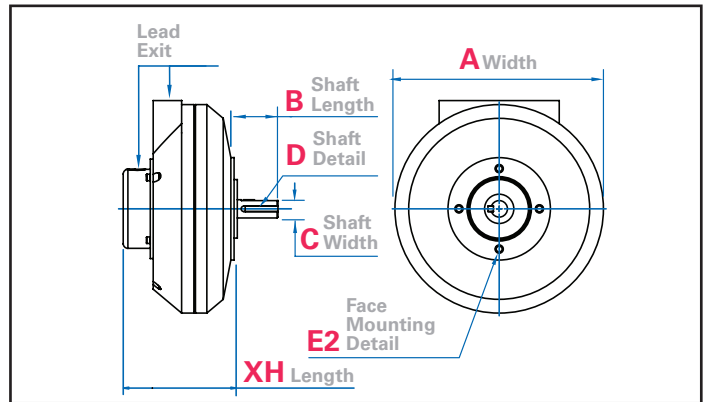

	Product Type	Weight (lbs.)	XH Length	A Diameter/Width (if square)	B Shaft Length	C Shaft Width	D Shaft Detail	E Mounting Detail (Through Holes)	E1 Flange Mounting Detail	E2 Face Mounting Detail	Lead/Cord Length (in.)
Flange Mount	7"	13	3.82	7.40	1.50	.626	Flat/key	[4] Thru Holes, .535 Dia. On 8.465 B.C.	[4] 3/8-16 UNC-2B x .50 Max. Deep on 5.875 B.C.	—	72
Face Mount	7"	12	3.87	7.13	1.50	.625	Flat/key	—	—	[4] 1/4-20 UNC-2B x .31 Max. Deep on 2.75 B.C.	72
	14"	75	5.47	14.06	1.75	1.000				[4] 3/8-16 UNC-2B x .50 Max. Deep on 6.50 B.C.	

## Control Dimensions

pages 24-28

Enclosed Models

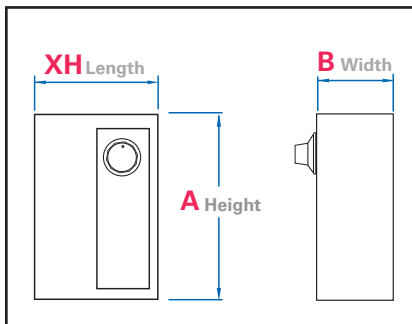

Chassis Models

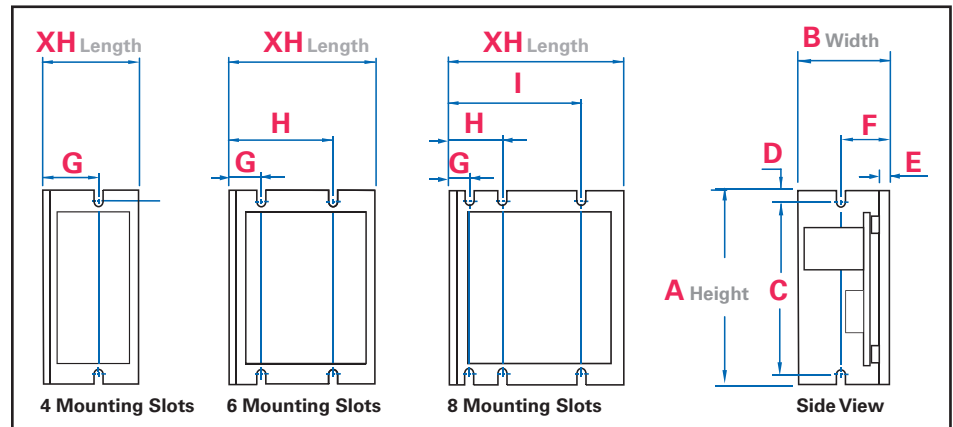

Enclosed Models

	Model Number	Description	XH Length	A Height	B Width
NEMA 4X/1P-65	2994	AC Inverter	5.51	9.53	5.86
NEMA 1/1P-40	2998	AC Inverter	4.95	7.00	4.15
NEMA 1	2996	AC Inverter	7.116	4.96	5.672
NEMA 1	0790, 0791	DC	7.12	3.92	3.74
NEMA 12	see website	DC/BLDC	6.16	8.44	3.94

Chassis Models

	Model Number	Description	XH Length	A Height	B Width	C Slot Height	D Slot Center to Edge	E Heat Sink Thickness	F Side Slot to Edge	G Slot 1 to Edge	H Slot 2 to Edge	I Slot 3 to Edge
AC Inverter	2982, 2983, 2984	8 mounting slots	3.87	4.30	2.66	3.80	.25	—	.950	.485	1.235	2.985
	2987	6 mounting slots-no side slots	4.30	4.67	4.96	—	—					
(DC) WPM	see website	6 mounting slots	3.64	4.30	1.75	3.80	.25	.90	.95	.50	3.00	—
(DC) UPM	see website		3.64	4.30	1.50	3.80	.25	.90	.95	.50	3.00	—
(DC) FPM	0810		4.75	6.00	1.25	5.50	.25	—	.94	1.13	3.63	—
(DC) FPM	0830, 0850		5.00	9.25	2.14	8.25	.38	—	—	1.31	3.81	—
(BLDC) ABL	3911, 3921	6 mounting slots	5.50	8.00	2.63	7.50	.25	.188	.117	1.25	42.5	—
(BLDC) ABL Low Voltage	3905, 3907	4 mounting slots	3.90	8.00	2.25	7.50	.25	.188	1.283	2.25	—	—

# Standard products for demanding applications

## Gearmotors

Bodine offers a complete line of right angle, parallel shaft, and hollow shaft gearmotors with torque ratings from 6-1,000 lb-in. (0.7-113 Nm).

All gearmotors are available as fixed-speed AC, variable-speed AC, permanent magnet, and brushless DC models.

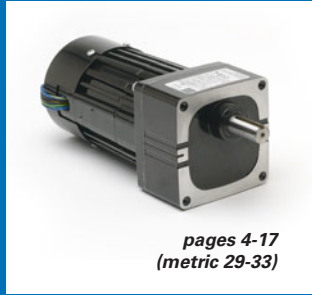

pages 4-17  
(metric 29-33)

## INTEGRAmotors™

Bodine's unique INTEGRAmotor combines a motion control, a brushless DC motor and a gearhead in one compact package. They provide simplified wiring, reduced panel space, faster assembly times and lower system costs.



## Controls

Our motion controls are precisely engineered to provide maximum performance from our motors and gearmotors.

Bodine designs and manufactures a complete line of permanent magnet DC controls for 90/130V PMDC motors, and brushless DC controls for 24V and 130VDC motors. We also offer 3-phase AC inverter controls.



page 24-28

## eTORQ™

Bodine's high performance, high torque direct drive system is ideal for applications that demand high efficiency, very compact design and enclosed construction.



page 23

